

PRACTICE EXERCISES

SINGLE CORRECT CHOICE TYPE QUESTIONS

This section contains Single Correct Choice Type Questions. Each question has four choices (A), (B), (C) and (D), out of which ONLY ONE is correct.

- A body of mass 2 kg is moving towards east with a uniform speed of 2 ms^{-1} . A force of 3 N is applied to it towards north. The magnitude of the displacement of the body 2 s after the application of force is

(A) 4 m (B) 5 m
(C) 6 m (D) 7 m
- A block of mass m , is placed on an inclined plane of mass M moving towards right horizontally with an acceleration $a_0 = g$. The length of the plane $AC = 1 \text{ m}$. Friction is absent everywhere. The time taken by the block to reach C starting from A is ($g = 10 \text{ ms}^{-2}$)

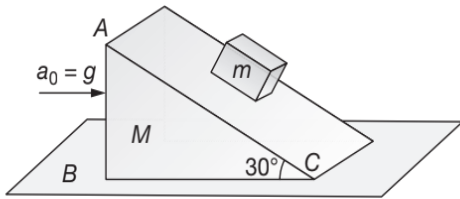

- (A) 0.42 s (B) 0.74 s
(C) 1.2 s (D) 2.56 s
- Two masses each equal to m are lying on x -axis at $(-a, 0)$ and $(+a, 0)$, respectively, as shown in figure. They are connected by a light string. A force F is applied at the origin along vertical direction. As a result the masses move towards each other without losing contact with ground. The acceleration of each mass at the instant when the masses are at $(-x, 0)$ and $(x, 0)$ respectively is

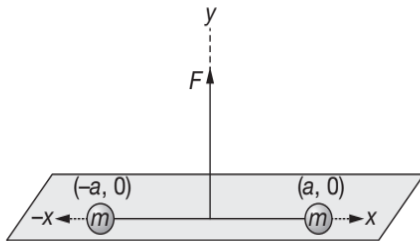

- (A) $\frac{2F}{m} \frac{\sqrt{a^2 - x^2}}{x}$ (B) $\frac{2F}{m} \frac{x}{\sqrt{a^2 - x^2}}$
(C) $\frac{F}{2m} \frac{x}{\sqrt{a^2 - x^2}}$ (D) $\frac{F}{m} \frac{x}{\sqrt{a^2 - x^2}}$
- A particle of mass M is attached to the lower end of a vertical rope of mass m . An upward force P acts on the upper end of the rope. The system is free to move. The force exerted by the rope on the block is $\frac{PM}{M+m}$

- (A) only if the rope is uniform
(B) in gravity-free space only
(C) only if $P > (M+m)g$
(D) in all cases

- A log of weight W is pulled at a constant velocity and with a force F by means of a rope of length L . The distance between the free end of the rope and the ground is h . Neglecting the thickness of the log the coefficient of friction between the log and the ground is

(A) $\mu = \frac{F\sqrt{L^2 - h^2}}{WL - Fh}$ (B) $\mu = \frac{\sqrt{L^2 - h^2}}{WL - Fh}$
(C) $\mu = \frac{WL - Fh}{F\sqrt{L^2 - h^2}}$ (D) $\mu = \frac{WL - Fh}{\sqrt{L^2 - h^2}}$

- Three identical rigid circular cylinders A, B and C are arranged on smooth inclined surfaces as shown in figure. The least value of θ that prevents the arrangement from collapsing is

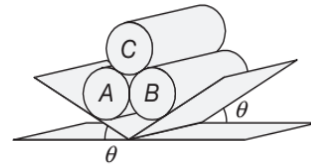

- (A) $\tan^{-1}\left(\frac{1}{2}\right)$ (B) $\tan^{-1}\left(\frac{1}{2\sqrt{3}}\right)$
(C) $\tan^{-1}\left(\frac{1}{3\sqrt{3}}\right)$ (D) $\tan^{-1}\left(\frac{1}{4\sqrt{3}}\right)$

- The greatest height h of the sand pile that can be erected without spilling the sand onto the surrounding circular area of radius R (if μ is the coefficient of friction between sand particles) is

(A) R (B) $\frac{R}{\mu}$
(C) μR (D) $\mu^2 R$

- In the arrangement shown in figure, coefficient of friction between the two blocks is $\mu = \frac{1}{2}$. The force of friction acting between the two blocks is

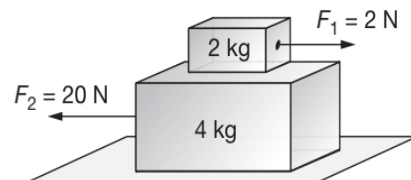

6.136 JEE Advanced Physics: Mechanics - I

- (A) 4 N (B) 6 N
(C) 8 N (D) 10 N

9. A bead of mass m is fitted on a rod and can move on it without friction. Initially the bead is at the middle of the rod and the rod moves translationally in a horizontal plane with an acceleration a_0 in a direction forming an α with the rod. The acceleration of bead with respect to rod is

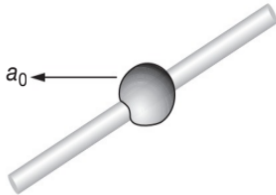

- (A) $g \sin \alpha$ (B) $(g + a_0) \sin \alpha$
(C) $g \sin \alpha + a_0 \cos \alpha$ (D) $g \sin \alpha - a_0 \cos \alpha$

10. A block of mass 10 kg lies on a rough inclined plane of inclination $\theta = \sin^{-1}\left(\frac{3}{5}\right)$ with the horizontal when a force of 30 N is applied on the block parallel to and upward the plane, the total force exerted by the plane on the block is nearly along (coefficient of friction is $\mu = \frac{3}{4}$) ($g = 10 \text{ ms}^{-2}$)

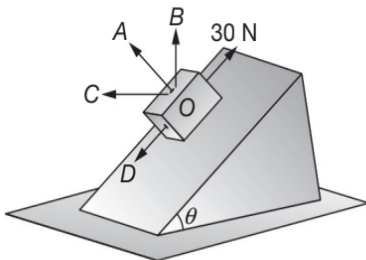

- (A) OA (B) OB
(C) OC (D) OD

11. In **PROBLEM 10**, the acceleration of the block is
(A) 3 ms^{-2} up the plane
(B) 3 ms^{-2} down the plane
(C) 6 ms^{-2} up the plane
(D) zero

12. A ball of mass m is thrown upward with a velocity v . If air exerts an average resisting force F , the velocity with which the ball returns to the thrower is

- (A) $v \sqrt{\frac{mg}{mg + F}}$ (B) $v \sqrt{\frac{F}{mg + F}}$
(C) $v \sqrt{\frac{mg - F}{mg + F}}$ (D) $v \sqrt{\frac{mg + F}{mg - F}}$

13. In the arrangement shown in figure $m_A = m_B = 2 \text{ kg}$. String is massless and pulley is frictionless. Block B is resting on a smooth horizontal surface, while

friction coefficient between blocks A and B is $\mu = 0.5$. The maximum horizontal force F that can be applied so that block A does not slip over the block B is (take $g = 10 \text{ ms}^{-2}$).

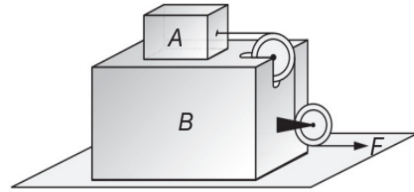

- (A) 25 N (B) 40 N
(C) 30 N (D) 20 N

14. The pulleys and strings shown in the figure are smooth and of negligible mass. For the system to remain in equilibrium, the angle θ should be

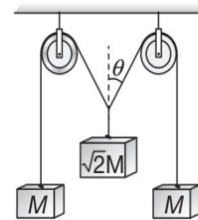

- (A) 0° (B) 30°
(C) 45° (D) 60°

15. In the arrangement shown, $m_1 = 1 \text{ kg}$, $m_2 = 2 \text{ kg}$, the pulleys and strings are ideal and all surfaces in contact are frictionless. The value of M for which the mass m_1 moves with constant velocity is

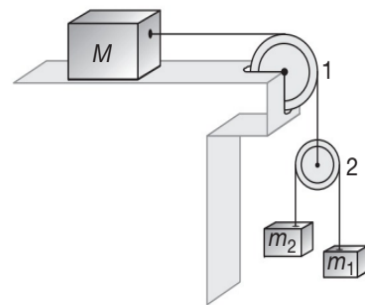

- (A) 6 kg (B) 4 kg
(C) 8 kg (D) 10 kg

16. In the figure shown the force with which the man should pull the rope to hold the plank in position is F . If weight of the man is 60 kgf, the plank and pulleys have negligible masses, then

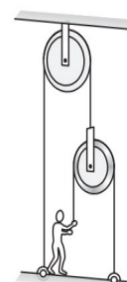

6.138 JEE Advanced Physics: Mechanics - I

23. The magnitude of the force (in N) acting on a body varies with time t (in μs) as shown in figure. AB , BC and CD are straight line segments. The magnitude of the total impulse of the force on the body from $t = 4 \mu\text{s}$ to $t = 16 \mu\text{s}$ is

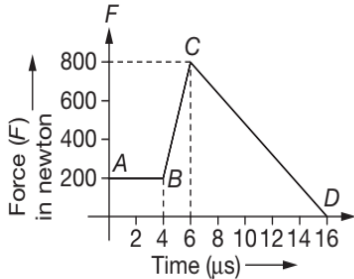

- (A) $5 \times 10^{-3} \text{Ns}$ (B) $5 \times 10^{-4} \text{Ns}$
 (C) $5 \times 10^{-2} \text{Ns}$ (D) $5 \times 10^{-1} \text{Ns}$
24. Blocks A and C start from rest and move to the right with acceleration $a_A = 12t \text{ ms}^{-2}$ and $a_C = 3 \text{ ms}^{-2}$. Here t is in second. The time when block B again comes to rest is

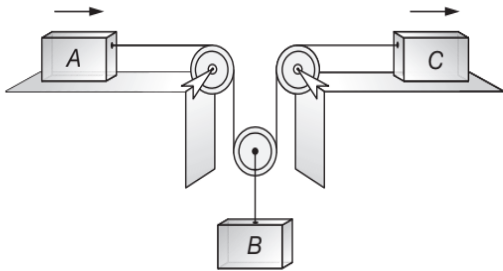

- (A) 2 s (B) 1 s
 (C) $\frac{3}{2}$ s (D) $\frac{1}{2}$ s
25. Two blocks A and B of masses m and M respectively are placed on each other and their combination rests on a fixed horizontal surface C . A light string passing over the smooth light pulley is used to connect A and B as shown. The coefficient of sliding friction between all surfaces in contact is μ . If A is dragged with a force F then for both A and B to move with a uniform speed we have

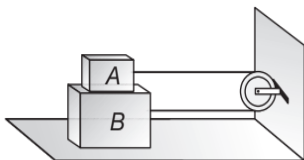

- (A) $F = \mu(M + m)g$ (B) $F = \mu mg$
 (C) $F = \mu(3M + m)g$ (D) $F = \mu(3m + M)g$
26. In a horizontal circle of radius R a particle P is rotating with a constant speed v . Another particle Q is moving along the diameter of the circle with a constant acceleration $a = \frac{v^2}{R}$. Net force on P as observed by Q is

- (A) constant both in magnitude and direction
 (B) constant in magnitude only
 (C) zero at least once during one rotation
 (D) None of these

27. Sixteen balls of equal masses are connected like beads on a string. Some balls are placed on a smooth inclined plane of inclination $\sin^{-1}\left(\frac{1}{3}\right)$ and the remaining balls hang over the top of the plane. The number of balls hanging so as to produce an acceleration of $\frac{g}{2}$ is
- (A) 8 (B) 9
 (C) 10 (D) 11

28. A block is kept on a smooth inclined plane of angle of inclination 30° that moves with a constant acceleration so that the block does not slide relative to the inclined plane. Let F be the contact force between the block and the plane. Now the inclined plane stops and let f be the contact force between the two in this case. Then $\frac{F}{f}$ is

- (A) 1 (B) $\frac{4}{3}$
 (C) 2 (D) $\frac{3}{2}$

29. A box is put on a scale which is adjusted to read zero when the box is empty. A stream of pebbles is then poured into the box from a height h above its bottom at a rate of n pebbles per second. Each pebble has a mass m . If the pebbles collide with the box such that they immediately come to rest after collision. Then the scale reading at time t after the pebbles begin to fill the box is

- (A) $mngt$ (B) $mn\sqrt{2gh}$
 (C) mg (D) $mn(\sqrt{2gh} + gt)$

30. A horizontal force F is applied on a very light rod inserted between the two identical blocks A and B placed over a rough surface as shown in figure. If the force F is gradually increased, then which of the blocks will move first?

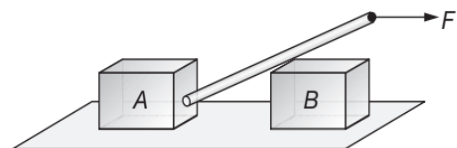

- (A) A
 (B) B
 (C) both move simultaneously
 (D) This depends on the friction coefficient between the blocks and the ground

31. An inclined plane makes an angle 30° with the horizontal. A groove $OA = 5\text{ m}$ cut in the plane makes an angle 30° with OX . A short smooth body is free to slide down the influence of gravity. The time taken by the body to reach from A to O is ($g = 10\text{ ms}^{-2}$)

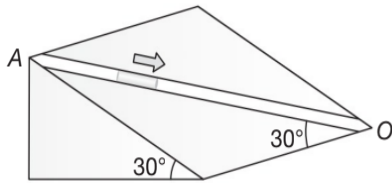

- (A) 4 s
(B) 2 s
(C) $2\sqrt{2}$ s
(D) 1 s

32. In the arrangement shown, the wall is smooth, but the surfaces of blocks A and B in contact are rough. In the state of equilibrium, the force of friction on B due to A is

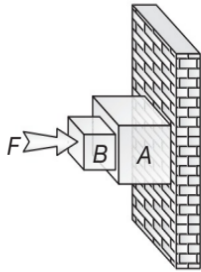

- (A) zero
(B) upwards
(C) downwards
(D) such that the system cannot stay in equilibrium

33. An elevator accelerates upward at a constant rate. A uniform string of length L and mass m supports a small block of mass M that hangs from the ceiling of an elevator which accelerates upwards at a constant rate. The tension at distance l from the ceiling is T . The acceleration of the elevator is

- (A) $\frac{T}{\left(2M + m - \frac{ml}{L}\right)} + g$ (B) $\frac{T}{\left(2M - m + \frac{ml}{L}\right)} - g$
(C) $\frac{T}{\left(M + m - \frac{ml}{L}\right)} - g$ (D) $\frac{T}{\left(M + \frac{ml}{L}\right)} - g$

34. A plumb bob is hung from the ceiling of a train compartment. The train moves on an inclined track of inclination 30° with horizontal. Acceleration of train up the plane is $a_0 = \frac{g}{2}$. The angle which the string supporting the bob makes with normal to the ceiling in equilibrium is

- (A) 30° (B) $\tan^{-1}\left(\frac{2}{\sqrt{3}}\right)$
(C) $\tan^{-1}\left(\frac{\sqrt{3}}{2}\right)$ (D) $\tan^{-1}(2)$

35. A solid sphere will be in stable equilibrium when its centre of gravity lies
(A) vertically above its centre
(B) vertically below its centre
(C) on the horizontal line through its centre
(D) none of the above
36. Two masses m and M are attached with strings as shown. For the system to be in equilibrium we have

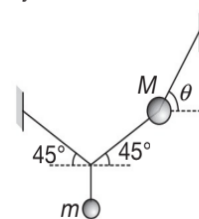

- (A) $\tan\theta = 1 + \frac{2M}{m}$ (B) $\tan\theta = 1 + \frac{2m}{M}$
(C) $\tan\theta = 1 + \frac{M}{2m}$ (D) $\tan\theta = 1 + \frac{m}{2M}$

37. In the system shown in figure $m_B = 4\text{ kg}$, and $m_A = 2\text{ kg}$. The pulleys are massless and friction is absent everywhere. The acceleration of block A is ($g = 10\text{ ms}^{-2}$)

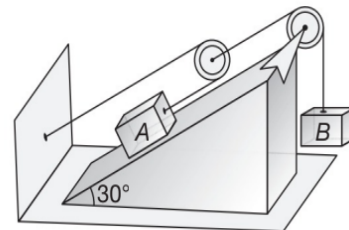

- (A) $\frac{10}{3}\text{ ms}^{-2}$ (B) $\frac{20}{3}\text{ ms}^{-2}$
(C) 2 ms^{-2} (D) 4 ms^{-2}

38. In the arrangement shown the pulleys and the strings are ideal. The respective accelerations of the blocks A and B are

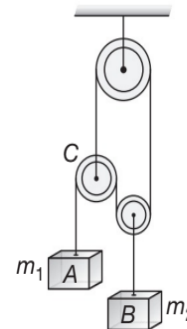

- (A) $g, \frac{g}{2}$ (B) $\frac{g}{2}, g$
(C) $\frac{3g}{2}, \frac{3g}{4}$ (D) g, g

6.140 JEE Advanced Physics: Mechanics - I

39. Beads A and B, each of mass m , are connected by a light inextensible cord. They are constrained (restricted) to move on a frictionless ring in a vertical plane as shown. The beads are released from rest at the positions shown. The tension in the cord just after the release is

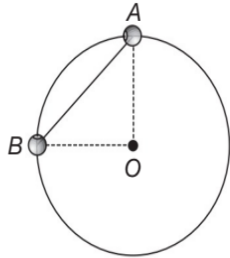

- (A) $\sqrt{2}mg$ (B) mg
 (C) $\frac{mg}{\sqrt{2}}$ (D) $2mg$
40. Two unequal masses are connected by a light inextensible string which passes over a frictionless light pulley. After the system has moved from rest for 3 s, the string is cut. If the lighter mass ascends $\frac{49}{90}$ m before it begins to descend and the heavier mass is 5 kg then the lighter mass is
- (A) 4 kg (B) 3 kg
 (C) 10 kg (D) 12 kg
41. A block A of mass m is placed over a plank B of mass $2m$. Plank B is placed over a smooth horizontal surface. The coefficient of friction between A and B is $\frac{1}{2}$. Block A is given a velocity v_0 towards right. Acceleration of B relative to A is

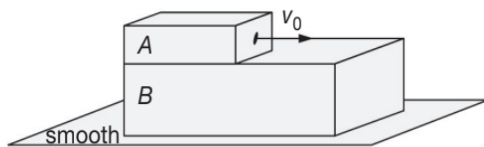

- (A) $\frac{g}{2}$ (B) g
 (C) $\frac{3g}{4}$ (D) zero
42. An automobile enters a turn whose radius is R . The road is banked at angle θ . Friction is negligible between wheels of the automobile and road. Mass of the automobile is m and speed is v . Select the correct alternative
- (A) net force on the automobile is zero
 (B) normal reaction on the automobile is $mg \cos \theta$
 (C) normal reaction on the automobile is $mg \sec \theta$
 (D) net force on the automobile is $\sqrt{(mg)^2 + \left(\frac{mv^2}{R}\right)^2}$

43. Three blocks A, B and C of equal mass m are placed one over the other on a smooth horizontal ground as shown in figure. Coefficient of friction between any two blocks of A, B and C is $\frac{1}{2}$ and that between C and ground is zero. The maximum value of mass of block D so that the blocks A, B and C move without slipping over each other is

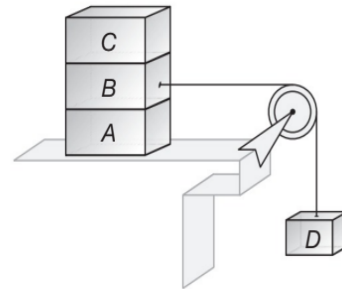

- (A) 3 m (B) 4 m
 (C) 5 m (D) 6 m
44. A block of mass $m = 4$ kg is placed over a rough inclined plane having coefficient of friction $\mu = 0.6$ as shown in figure. A force $F = 10$ N is applied on the block at an angle of 30° . The contact force between the block and the plane is

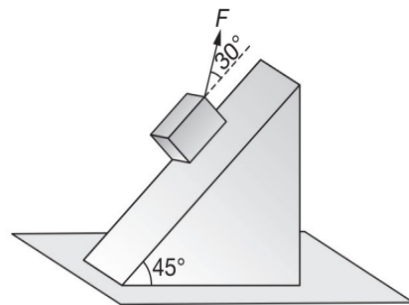

- (A) 10.65 N (B) 16.32 N
 (C) 27.15 N (D) 32.16 N
45. On a fixed wedge, two blocks A and B are placed as shown. The coefficient of friction between the block A of mass m and block B of mass $2m$ is μ . There is no friction between block B and the inclined plane. If the system of blocks A and B is released from rest, then for no slipping between A and B, we have

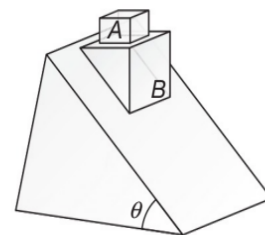

- (A) $\theta \leq \cos^{-1}(2\mu)$ (B) $2\theta \leq \tan^{-1}\left(\frac{\mu}{2}\right)$
 (C) $2\theta \leq \tan^{-1}(2\mu)$ (D) $\theta \leq \tan^{-1}(\mu)$

46. In the arrangement shown, two bodies of mass m and $4m$ are attached with string. The body of mass m hanging from the string of length l is executing oscillations of angular amplitude θ_0 while the other body is at rest. The minimum coefficient of friction between the mass $4m$ and the horizontal surface is

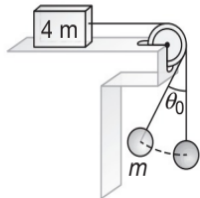

- (A) $\mu_{\text{MIN}} = \left(\frac{2 - \cos\theta_0}{3}\right)$ (B) $\mu_{\text{MIN}} = 2\cos^2\left(\frac{\theta_0}{2}\right)$
 (C) $\mu_{\text{MIN}} = \left(\frac{3 - \cos\theta_0}{4}\right)$ (D) $\mu_{\text{MIN}} = \left(\frac{3 - 2\cos\theta_0}{4}\right)$

47. The system shown in figure is released from rest. The spring gets elongated

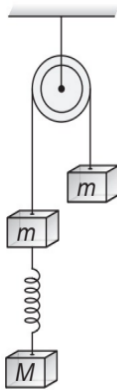

- (A) if $M > m$ (B) if $M > 2m$
 (C) if $M > \frac{m}{2}$ (D) for any value of M

(Neglect friction and masses of pulley, string and spring)

48. Two unequal masses are connected on two sides of a light string passing over a light and smooth pulley as shown in figure. The system is released from rest. The larger mass is stopped for a moment, 1 second after the system is set into motion. The time elapsed before the string is tight again is ($g = 10 \text{ ms}^{-2}$)

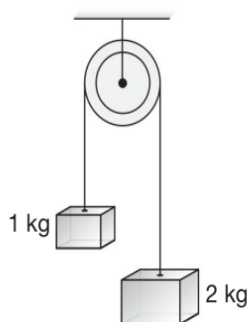

- (A) $\frac{1}{4} \text{ s}$ (B) $\frac{1}{2} \text{ s}$
 (C) $\frac{2}{3} \text{ s}$ (D) $\frac{1}{3} \text{ s}$

49. Given $m_A = 30 \text{ kg}$, $m_B = 10 \text{ kg}$, $m_C = 20 \text{ kg}$. Between A and B $\mu_1 = 0.3$, between B and C $\mu_2 = 0.2$ and between C and ground $\mu_3 = 0.1$. The least horizontal force F to start motion of any part of the system of three blocks resting upon one another as shown in figure is ($g = 10 \text{ ms}^{-2}$)

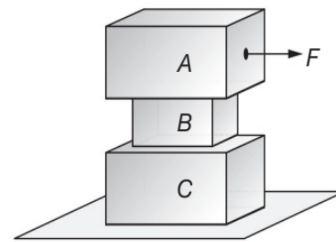

- (A) 60 N (B) 90 N
 (C) 80 N (D) 150 N

50. A car going at a speed of 6 ms^{-1} encounters an incline (inclination angle 30°) of length 15 m. The friction coefficient between the road and tyres is 0.5. The minimum speed of car with which it can reach the bottom is ($g = 10 \text{ ms}^{-2}$)

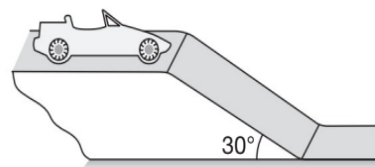

- (A) 10 ms^{-1} (B) 7.5 ms^{-1}
 (C) 5 ms^{-1} (D) 2.5 ms^{-1}

51. In order to raise a block of mass 100 kg a man of mass 60 kg fastens a rope to it and passes the rope over a smooth pulley. He climbs the rope with an acceleration $\frac{5g}{4}$ relative to rope. The tension in the rope is ($g = 10 \text{ ms}^{-2}$)

- (A) 1432 N (B) 928 N
 (C) 1218 N (D) 642 N

52. A light string fixed at one end to a clamp on ground passes over a fixed pulley and hangs at the other side. It makes an angle of 30° with the ground. A monkey of mass 5 kg climbs up the rope. The clamp can tolerate a vertical force of 40 N only. The maximum acceleration in upward direction with which the monkey can climb safely is (Neglect friction and take $g = 10 \text{ ms}^{-2}$)

6.142 JEE Advanced Physics: Mechanics - I

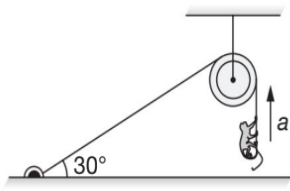

- (A) 2 ms^{-2} (B) 4 ms^{-2}
 (C) 6 ms^{-2} (D) 8 ms^{-2}

53. A block of mass 15 kg is resting on a rough inclined plane as shown in figure. The block is tied up by a horizontal string which has a tension of 50 N . The coefficient of friction between the surfaces of contact is ($g = 10 \text{ ms}^{-2}$)

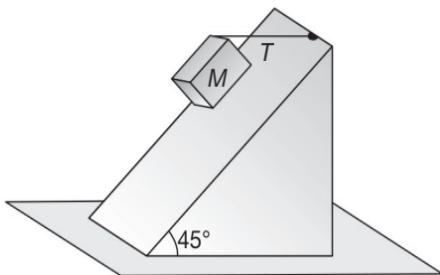

- (A) $\frac{1}{2}$ (B) $\frac{2}{3}$
 (C) $\frac{3}{4}$ (D) $\frac{1}{4}$

54. In the arrangement shown in figure, pulley is smooth and massless and all the strings are light. Let F_1 be the force exerted on the pulley in CASE-1 and F_2 the force in CASE-2. Then

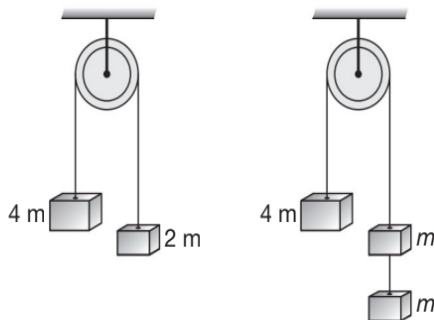

- (A) $F_1 > F_2$ (B) $F_1 < F_2$
 (C) $F_1 = F_2$ (D) $F_1 = 2F_2$

55. A block of mass m is placed on a rough horizontal plane attached with an elastic spring of spring constant k as shown in figure. Initially spring is unstretched. If the plane is now gradually lifted from $\theta = 0^\circ$ to $\theta = 90^\circ$, then the graph showing extension in the spring (x) versus angle (θ) is

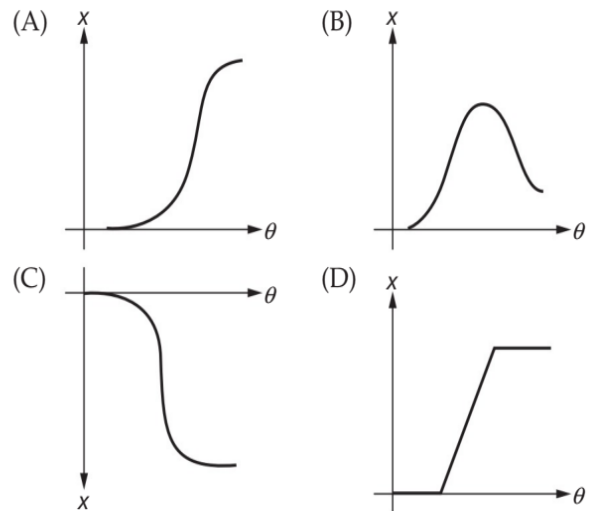
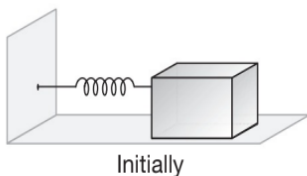

56. The maximum value of mass of block C so that neither A nor B moves is (Given that mass of A is 100 kg and that of B is 140 kg . Pulleys are smooth and friction coefficient between A and B and between B and horizontal surface is $\mu = 0.3$) $g = 10 \text{ ms}^{-2}$

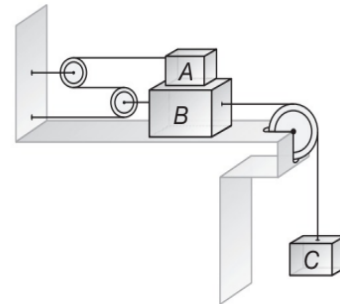

- (A) 210 kg (B) 190 kg
 (C) 185 kg (D) 162 kg

57. A homogeneous chain of length L lies on a table. The coefficient of friction between the chain and the table is μ . The maximum length which can hang over the table in equilibrium is (The vertical portion of table is smooth)

- (A) $\left(\frac{\mu}{\mu+1}\right)L$ (B) $\left(\frac{1-\mu}{\mu}\right)L$
 (C) $\left(\frac{1-\mu}{1+\mu}\right)L$ (D) $\left(\frac{2\mu}{2\mu+1}\right)L$

58. Consider the arrangement shown. Suppose all the surfaces are rough, the direction of friction on B due to A, on A due to wall and on A due to B is

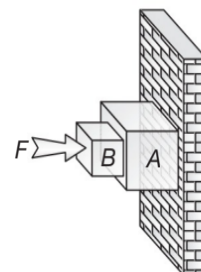

- (A) up, down, up
- (B) up, up, down
- (C) down, up, up
- (D) depends on the masses of A and B and friction coefficients at different surfaces

59. A block of mass m slides down an inclined plane of inclination θ with uniform speed. The coefficient of friction between the block and the plane is μ . The contact force between the block and the plane is

- (A) $mg \sin \theta \sqrt{1 + \mu^2}$
- (B) $\sqrt{(mg \sin \theta)^2 + (\mu mg \cos \theta)^2}$
- (C) $mg \sin \theta$
- (D) mg

60. A block of mass $m = 2$ kg is at rest on a rough inclined plane of inclination 30° as shown. The coefficient of friction between the block and the plane is $\mu = 0.5$. The minimum force F that must be applied on the block perpendicular to the plane, so that block does not slip on the plane is ($g = 10 \text{ ms}^{-2}$)

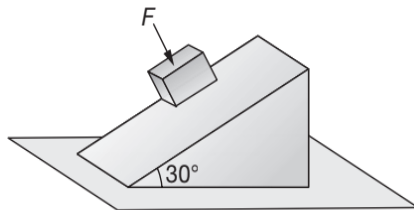

- (A) zero
- (B) 6.24 N
- (C) 2.68 N
- (D) 4.34 N

61. On a plank of mass 2 kg, length 1.25 m lying on a smooth horizontal ground, a block of mass 1 kg is placed. The coefficient of friction between the block and the plank is 0.5. A constant force $F = 35$ N is applied on the plank in horizontal direction. The time after which the block will separate from the plank is ($g = 10 \text{ ms}^{-2}$)

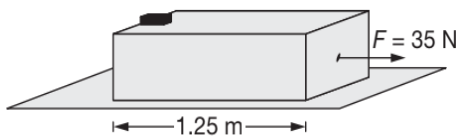

- (A) 0.25 s
- (B) 0.5 s
- (C) 1 s
- (D) 2 s

62. A body slides down an inclined plane of inclination θ . The coefficient of friction down the plane varies in direct proportion to the distance moved down the plane as $\mu = kx$, where k is a constant. The body will move down the plane with a

- (A) constant acceleration $g \sin \theta$.
- (B) constant acceleration $g(\sin \theta - \mu \cos \theta)$.
- (C) variable acceleration $g(\mu \sin \theta - \cos \theta)$.
- (D) variable acceleration first decreasing from $g \sin \theta$ to zero and then becoming negative.

63. A string of negligible mass going over a clamped pulley of mass m supports a block of mass M as shown in the figure. The force on the pulley by the clamp is given by

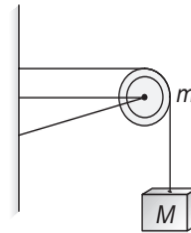

- (A) $\sqrt{2}Mg$
- (B) $\sqrt{2}mg$
- (C) $\left[\sqrt{(M+m)^2 + m^2} \right]g$
- (D) $\left[\sqrt{(M+m)^2 + M^2} \right]g$

64. A small particle of mass m is released from rest from point A inside a smooth hemispherical bowl as shown in figure. The ratio (x) of magnitude of centripetal force and normal reaction on the particle at any point B varies with θ as

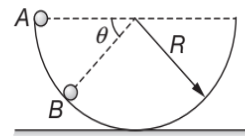

- (A)
- (B)
- (C)
- (D)

65. Three freight cars of mass M are pulled with force F by a locomotive. Friction is negligible. The ratio of the forces on each car from the end where F is applied is

- (A) 3 : 2 : 1
- (B) 1 : 2 : 3
- (C) 1 : 1 : 1
- (D) 3 : 1 : 2

66. A particle is moving in a circular path. The acceleration and momentum of the particle at a certain moment are $\vec{a} = (4\hat{i} + 3\hat{j}) \text{ ms}^{-2}$ and $\vec{p} = (8\hat{i} - 6\hat{j}) \text{ kgms}^{-1}$. The motion of the particle is

- (A) accelerated circular motion
- (B) de-accelerated circular motion
- (C) uniform circular motion
- (D) data insufficient to say anything with \vec{a} and \vec{p} only

6.144 JEE Advanced Physics: Mechanics - I

67. Assuming the gravity to be in negative z-direction, a force $\vec{F} = \vec{v} \times \vec{A}$ is exerted on a particle in addition to the force of gravity where \vec{v} is the velocity of the particle and \vec{A} is a constant vector in positive x-direction. The minimum speed \bar{v}_{\min} with which a particle of mass m must be projected so that it continues to move undeflected with constant velocity is

- (A) $\bar{v}_{\min} = -\frac{A}{mg} \hat{j}$ (B) $\bar{v}_{\min} = \frac{A}{mg} \hat{j}$
 (C) $\bar{v}_{\min} = \frac{mg}{A} \hat{j}$ (D) $\bar{v}_{\min} = -\frac{mg}{A} \hat{j}$

68. Two masses m and M are connected by a light string passing over a smooth pulley. When set free m moves up by 1.4 m in 2 s. The ratio $\frac{m}{M}$ is

- (A) $\frac{13}{15}$ (B) $\frac{15}{13}$
 (C) $\frac{9}{7}$ (D) $\frac{7}{9}$

69. An airplane requires for take-off a speed of 80 kmh^{-1} , the run on the ground being 100 m. The mass of the airplane is 10,000 kg and the coefficient of friction between the airplane and the ground is 0.2. Assuming that the plane accelerates uniformly during take-off, the minimum force required by the engine for take-off is

- (A) $2 \times 10^4 \text{ N}$ (B) $2.43 \times 10^4 \text{ N}$
 (C) $4.43 \times 10^4 \text{ N}$ (D) $8.86 \times 10^4 \text{ N}$

70. In the pulley arrangement shown, the pulley P_2 is movable. Assuming coefficient of friction between m and surface to be μ , the minimum value of M for which m is at rest is

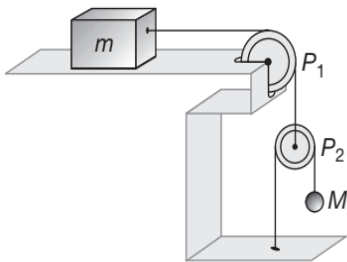

- (A) $M = \frac{\mu m}{2}$ (B) $m = \frac{\mu M}{2}$
 (C) $M = \frac{m}{2\mu}$ (D) $m = \frac{M}{2\mu}$

71. A block is gently dropped on a conveyor belt moving at 3 ms^{-1} . If the coefficient of friction between the belt and the block is 0.5. The displacement of block relative to the conveyor belt before the slipping between the two is stopped ($g = 10 \text{ ms}^{-2}$)

- (A) 0.9 m (B) 1.2 m
 (C) 1.8 m (D) 2.7 m

72. A block of mass m is held on a rough inclined plane by a spring parallel to the plane as shown. The natural length of the spring is l_0 and its force constant is λ . The frictional force is in magnitude proportional to the speed of the block. If l be the equilibrium length, then

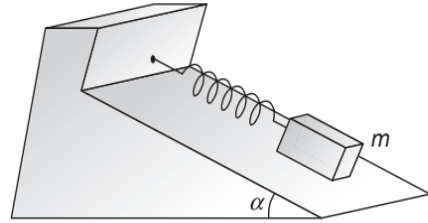

- (A) $l = l_0 \left(1 + \frac{2mg \sin \alpha}{\lambda} \right)$ (B) $l = l_0 \left(1 + \frac{mg \sin \alpha}{\lambda} \right)$
 (C) $l = l_0 \left(1 - \frac{2mg \sin \alpha}{\lambda} \right)$ (D) $l = l_0 \left(1 - \frac{mg \sin \alpha}{\lambda} \right)$

73. A car starts from rest to cover a distance of 500 m on a road whose coefficient of friction with the tyres of the car is $\frac{1}{2}$. The minimum time in which the car can cover this distance is ($g = 10 \text{ ms}^{-2}$)

- (A) 5 s (B) 10 s
 (C) 20 s (D) 40 s

74. A particle of mass m moving with velocity u makes an elastic one dimensional collision with a stationary particle of mass m . They are in contact for a very brief time T . Their force of interaction increases from zero to F_0 linearly in time $\frac{T}{2}$, and decreases linearly to zero in a further time $\frac{T}{2}$. The magnitude of F_0 is

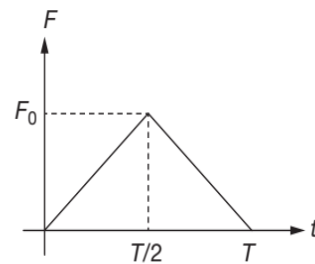

- (A) $\frac{mu}{2T}$ (B) $\frac{mu}{T}$
 (C) $\frac{2mu}{T}$ (D) None of these

75. Two blocks M and m are arranged as shown in the figure. The coefficient of friction between the blocks M and m is $\mu_1 = 0.25$ and between the ground and M is $\mu_2 = \frac{1}{3}$. If $M = 8 \text{ kg}$, then the value of m for which the system will remain at rest is

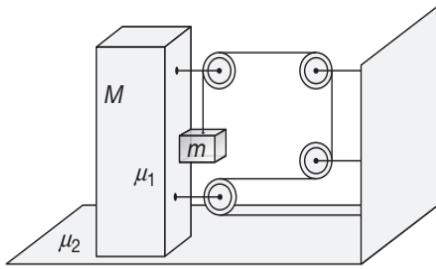

- (A) $\frac{4}{3}$ kg (B) $\frac{8}{9}$ kg
 (C) 1 kg (D) $\frac{8}{5}$ kg

76. Two blocks of masses m_1 and m_2 are connected with a light spring and placed over a plank moving with an acceleration a as shown in figure. The coefficient of friction between the blocks and plank is μ . The spring will

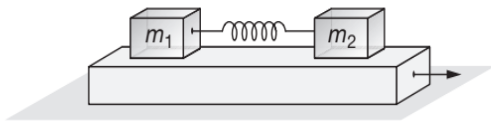

- (A) neither be compressed nor be stretched for $a \leq \mu g$
 (B) be compressed if $a \leq \mu g$
 (C) be stretched if $a > \mu g$
 (D) be in its natural length under all conditions

77. A block is about to slide down an inclined plane when its angle to the horizontal is θ . If now another block of same mass is put on the block

- (A) it will not slide down the plane unless the inclination is increased
 (B) it can remain in equilibrium even if the inclination is slightly decreased
 (C) it will about to slide when the inclination is greater than $\frac{\theta}{2}$
 (D) it is still about to slide down the plane

78. In CASE-1, the wedge B is stationary and block A starts sliding when the angle of plane is greater than θ , while in CASE-2, the wedge B is moving upwards with an acceleration a_0 and the block A starts sliding when the angle of plane is greater than α . The coefficient of friction between A and B in both the cases is same. Then

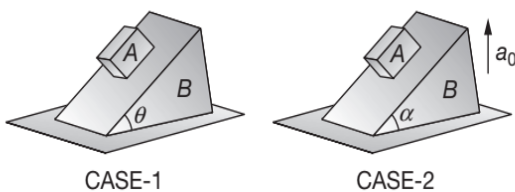

- (A) $\frac{\tan \theta}{\tan \alpha} = \frac{g}{a_0}$ (B) $\theta < \alpha$
 (C) $\theta > \alpha$ (D) $\theta = \alpha$

79. Two spheres of equal masses are attached to a string of length 2 m as shown. The string and the spheres are then whirled in a horizontal circle about O at a constant rate. If T_1 is the tension in the string between P & Q and T_2 is the tension in the string between P & O then $\frac{T_1}{T_2}$ equals

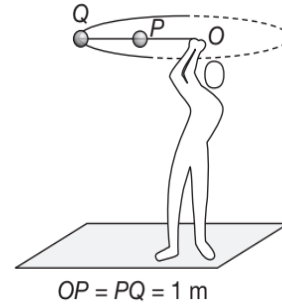

- (A) 1 (B) $\frac{1}{3}$
 (C) $\frac{2}{3}$ (D) $\frac{1}{2}$

80. A pendulum of mass m hangs from a support fixed to a trolley. The direction of the string when the trolley rolls up a plane of inclination α with acceleration a_0 is

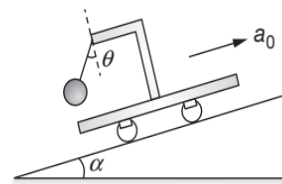

- (A) $\theta = \tan^{-1} \alpha$
 (B) $\theta = \tan^{-1} \left(\frac{a_0}{g} \right)$
 (C) $\theta = \tan^{-1} \left(\frac{g}{a_0} \right)$
 (D) $\theta = \tan^{-1} \left(\frac{a_0 + g \sin \alpha}{g \cos \alpha} \right)$

81. A car is moving in a circular horizontal track of radius 10 m with a constant speed of 10 ms^{-1} . A plumb bob is suspended from the roof of the car by a light rigid rod of length 1 m. The angle made by the rod with the track is

- (A) 0° (B) 30°
 (C) 45° (D) 60°

82. A block is placed on a rough inclined plane having inclination angle θ . Now, the angle θ is increased from 0° to 90° , then the contact force between the block and the plane

- (A) remains constant
 (B) first increases then decreases
 (C) first decreases then increases
 (D) first remains constant then decreases

6.146 JEE Advanced Physics: Mechanics - I

83. A particle of mass m , initially at rest, is acted upon by a variable force F for a brief interval of time T . It begins to move with a velocity u after the force stops acting. F is shown in the graph as a function of time. The curve is an ellipse

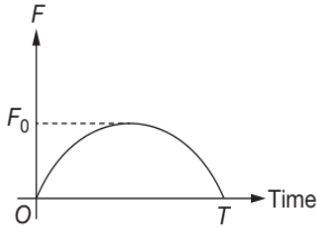

- (A) $u = \frac{\pi F_0^2}{2m}$ (B) $u = \frac{\pi T^2}{8m}$
 (C) $u = \frac{\pi F_0 T}{4m}$ (D) $u = \frac{F_0 T}{2m}$
84. A ball of mass 1 kg is released from position A inside a wedge which has a hemispherical cut of radius 0.5 m as shown. Assuming all surfaces to be smooth, the force exerted by the vertical wall OM on wedge, when the ball is in position B is ($g = 10 \text{ ms}^{-2}$)

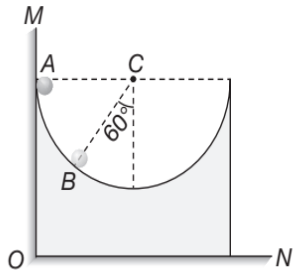

- (A) $5\sqrt{3} \text{ N}$ (B) 10 N
 (C) $\frac{15\sqrt{3}}{2} \text{ N}$ (D) 15 N
85. A bar of mass m resting on a smooth horizontal plane starts moving due to a force $F = \frac{mg}{3}$ of constant magnitude. In the process of its rectilinear motion, the angle θ between the direction of this force and the horizontal varies as $\theta = ks$, where k is a constant and s is the displacement of the particle. The velocity of bar as a function of θ is

- (A) $v = \sqrt{\frac{2g}{3} \sin \theta}$ (B) $v = \sqrt{\frac{2g}{3} \cos \theta}$
 (C) $v = \sqrt{\frac{2g}{3k} \sin \theta}$ (D) $v = \sqrt{\frac{2g}{3k} \cos \theta}$

86. Two small balls each having a radius R , having masses m_1 and m_2 ($m_1 > m_2$), tied by a thin light thread are dropped from a certain height. Taking upward buoyancy force F into account, the tension T in the thread during the flight when the motion of the balls becomes uniform is

- (A) $(m_1 - m_2)g$ (B) $(m_1 - m_2)\frac{g}{2}$
 (C) $(m_1 + m_2)g$ (D) $(m_1 + m_2)\frac{g}{2}$

87. On an inclined plane of inclination angle 30° , a block is placed. It is observed that the force to drag the block along the plane upwards is smaller than the force required to lift it. The maximum value of coefficient of friction is

- (A) $\frac{\sqrt{3}}{2}$ (B) $\frac{1}{2}$
 (C) $\frac{1}{\sqrt{3}}$ (D) $\frac{2}{3}$

88. In the arrangement shown, the string is light, pulley is smooth, the total mass on left hand side of the pulley is m_1 , on right hand side is m_2 , the coefficient of friction between block B and the wedge is $\mu = \frac{1}{2}$ and the inclination angle is $\theta = 30^\circ$. Select the incorrect option.

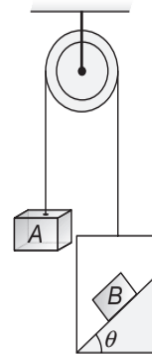

- (A) Block B will slide down if $m_1 = m_2$
 (B) Block B may remain stationary with respect to wedge for suitable values of m_1 and m_2 with $m_2 > m_1$
 (C) Block B will slide down if $m_1 > m_2$
 (D) Block B cannot remain stationary with respect to wedge in any case
89. A horizontal force F is applied to a block of mass m on a smooth inclined plane of inclination θ to the horizontal as shown in figure. The resultant force on the block is

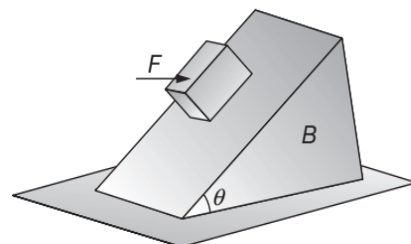

- (A) $F \sin \theta - mg \cos \theta$ (B) $F + mg \tan \theta$
 (C) $F \sin \theta + mg \cos \theta$ (D) $F \cos \theta - mg \sin \theta$

90. A 4 kg block is connected with two springs of force constants $k_1 = 100 \text{ Nm}^{-1}$ and $k_2 = 300 \text{ Nm}^{-1}$ as shown in figure. The block is released from rest with the springs unstretched. The acceleration of the block in its lowest position is ($g = 10 \text{ ms}^{-2}$)

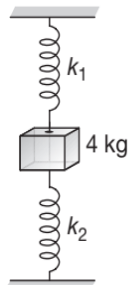

- (A) zero (B) 5 ms^{-2} upwards
 (C) 10 ms^{-2} downwards (D) 10 ms^{-2} upwards
91. A man of mass 60 kg is pulling a block of mass M by an inextensible light rope passing through a smooth and massless pulley as shown in figure. The coefficient of friction between the man and the ground is $\mu = \frac{1}{2}$. The maximum value of M that can be pulled by the man without slipping on the ground is approximately

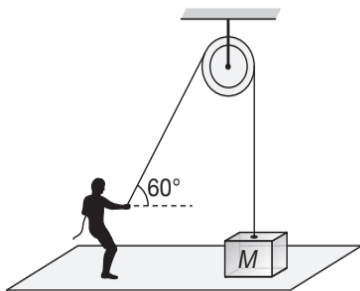

- (A) 26 kg (B) 32 kg
 (C) 46 kg (D) 51 kg
92. A wooden block of mass M resting on a rough horizontal floor is pulled with a force F at an angle ϕ with the horizontal. If μ is the coefficient of kinetic friction between the block and the surface, then acceleration of the block is
- (A) $\frac{F}{M} \sin \phi$
 (B) $\mu F \cos \phi$
 (C) $\frac{F}{M} (\cos \phi - \mu \sin \phi) - \mu g$
 (D) $\frac{F}{M} (\cos \phi + \mu \sin \phi) - \mu g$

93. An electric fan is placed on a stationary boat and air is blown with it on the sail of the boat. Select the correct statement(s) from the following.
- (A) The boat will start moving with a uniform speed.
 (B) The boat will be uniformly accelerated in the direction of flow of the air.

- (C) The boat will be uniformly accelerated opposite to the direction of the flow of air.
 (D) The boat will remain stationary as before.

94. In a tug-of-war contest, two teams A and B pull on a horizontal rope from the opposite sides. The winner team will be the one who
- (A) exerts greater force on the rope.
 (B) exerts greater force on the ground.
 (C) exerts a force on the rope greater than the tension existing in the rope.
 (D) data insufficient to arrive at a result.
95. A bowl of soup rests on a table in the dining car of a train. If the acceleration of the train is a_0 in the forward direction then the angle which the surface of the soup makes with the horizontal is
- (A) $\arctan\left(\frac{a_0}{g}\right)$ (B) $\arctan\left(\frac{g}{a_0}\right)$
 (C) $\arctan\left(\frac{a_0}{\sqrt{a_0^2 + g^2}}\right)$ (D) $\arctan\left(\frac{g}{\sqrt{a_0^2 + g^2}}\right)$

96. A block of metal weighing 2 kg is resting on a frictionless plane. It is struck by a jet of water at a rate of 1 kg s^{-1} at a speed of 5 ms^{-1} . The initial acceleration of the block is
- (A) $\frac{2}{5} \text{ ms}^{-2}$ (B) $\frac{5}{2} \text{ ms}^{-2}$
 (C) 5 ms^{-2} (D) $\frac{1}{5} \text{ ms}^{-2}$

97. A particle of mass m moves along the internal smooth surface of a vertical cylinder of radius R as shown. The force which acts on the wall of the cylinder if initially the velocity v_0 of the particle makes an angle α with the horizontal (Assume that particle does not leave contact with the curved surface of the cylinder) is

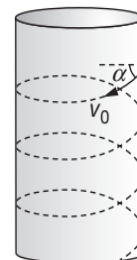

- (A) $\frac{mv_0^2}{R}$ (B) $\frac{mv_0^2 \cos^2 \alpha}{R}$
 (C) $\frac{mv_0^2 \sin^2 \alpha}{R}$ (D) mg

98. In the figure, the ball B is released from rest when the spring is at its natural length. For the block A of mass $2m$ to leave contact with the ground at some instant, the minimum mass of B must be

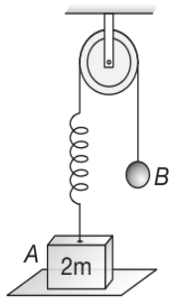

- (A) $2m$ (B) m
 (C) $\frac{m}{2}$ (D) $\frac{m}{4}$

99. A blimp of mass m is descending with an acceleration a_0 . A buoyant force is acting on the blimp which is equal to the weight of the air displaced by the blimp. Assuming the buoyant force to be constant the ballast that must be jettisoned from the blimp so that it rises with same acceleration a_0 is

- (A) $\left(\frac{2g}{g+a_0}\right)m$ (B) $\left(\frac{2a_0}{g}\right)m$
 (C) $\left(\frac{2a_0}{g+a_0}\right)m$ (D) $\left(\frac{2a_0}{g-a_0}\right)m$

100. A car with closed windows takes a left turn. A helium filled balloon in the car will be pushed to the

- (A) right (B) left
 (C) front (D) back

101. According to the basic postulates of the "Theory of Relativity", the laws of Physics are same in

- (A) all frames of reference.
 (B) Only those frames of reference which move at constant velocity with respect to an inertial frame.
 (C) only those frames of reference which move at constant acceleration with respect to an inertial frame.
 (D) only those frames which rotate with constant angular velocity with respect to an inertial frame.

102. A string with constant tension T is deflected through an angle $2\theta_0$ by a smooth fixed pulley. The force on the pulley is

- (A) $2T \cos \theta_0$ (B) $T \cos \theta_0$
 (C) $2T \sin \theta_0$ (D) $T \sin \theta_0$

103. A man running along a straight road leans a little in the forward direction. The angle between the vertical line and the line joining the man's centre of gravity with the point of support is θ_0 . For the man not to slip, the coefficient of friction satisfies the condition given by

- (A) $\mu \leq \tan \theta_0$ (B) $\mu \geq \tan \theta_0$
 (C) $\mu \geq \tan^2 \theta_0$ (D) $\mu \leq \tan^2 \theta_0$

104. Vertically hanging curtains between the compartments in an airplane are seen to bend forward. This indicates that the airplane is

- (A) taking off
 (B) moving steadily at constant altitude
 (C) slowing down for landing
 (D) taking a bend

105. A particle of mass m rests on a horizontal floor with which it has a coefficient of static friction μ . For the block to just move

- (A) A minimum force $F_{\min} = \frac{\mu mg}{\sqrt{1+\mu^2}}$ has to be

applied at an angle $\theta = \tan^{-1}\left(\frac{1}{\mu}\right)$ with the horizontal.

- (B) A minimum force $F_{\min} = \mu mg$ has to be applied at an angle $\theta = \tan^{-1}(\mu)$ with the horizontal.

- (C) A minimum force $F_{\min} = \frac{\mu mg}{\sqrt{1+\mu^2}}$ has to be

applied at an angle $\theta = \tan^{-1}(\mu)$ with the horizontal.

- (D) A minimum force $F_{\min} = \mu mg$ has to be applied at an angle $\theta = \tan^{-1}\left(\frac{1}{\mu}\right)$ with the horizontal.

106. A prism of mass M is placed on a horizontal surface. A block of mass m slides on it, which in turn slides on the horizontal surface. Assume all surfaces to be frictionless the acceleration of the block with respect to the prism is

- (A) $g \sin \theta$ (B) $g \cos \theta$

- (C) $\left(\frac{M+m}{M+m \sin^2 \theta}\right)g \sin \theta$ (D) $\left(\frac{M+m}{M+m \sin^2 \theta}\right)g \cos \theta$

107. A body slides over an inclined plane forming an angle of 45° with the horizontal. The distance x travelled by the body in time t is described by the equation $x = kt^2$, where $k = 1.732$. The coefficient of friction between the body and the plane has a value

- (A) $\mu = 0.5$ (B) $\mu = 1$
 (C) $\mu = 0.25$ (D) $\mu = 0.75$

108. The inclined plane shown in figure has an acceleration \vec{a}_0 to the right. If $\mu_s = \tan \theta$ is the coefficient of static friction for all surfaces in contact. The block will slide on the plane for

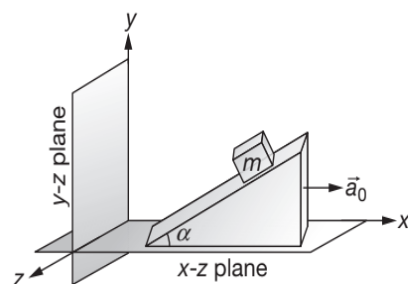

6.150 JEE Advanced Physics: Mechanics - I

117. A block A is placed over a long rough plank B of same mass as shown in figure. The plank is placed over a smooth horizontal surface. At time $t = 0$, block A is given a velocity v_0 in horizontal direction. Let v_1 and v_2 be the velocities of A and B at time t . Then the correct graph between v_1 or v_2 and t is

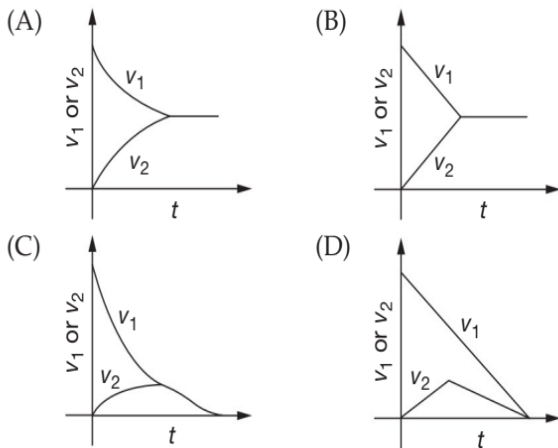
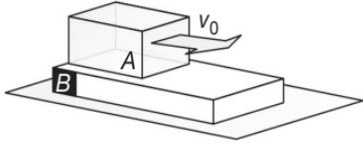

118. A block B is placed on block A . The mass of block B is less than the mass of block A . Friction exists between the blocks, whereas the ground on which the block A is placed is taken to be smooth. A horizontal force F , increasing linearly with time begins to act on B . The acceleration a_A and a_B of blocks A and B respectively are plotted against t . The correctly plotted graph is

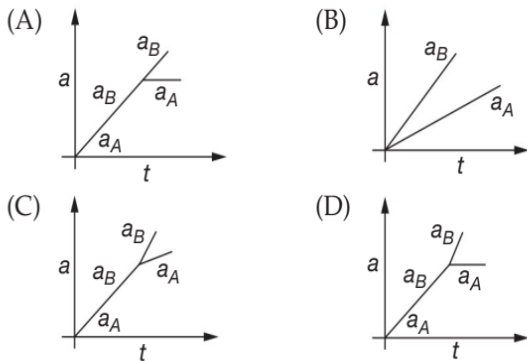
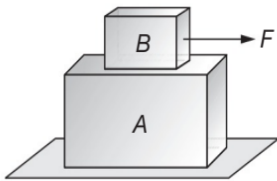

119. A mass m is drawn up a smooth inclined plane of height h and length l by means of a string passing over a pulley fixed at the vertex of the plane as shown. A mass M hangs from the other end. For m to

just reach the top of the plane, M must be detached when m has moved through a distance

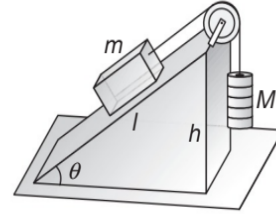

- (A) $\frac{mh}{M}$ (B) $\frac{ml}{M}$
 (C) $\frac{M}{M+m} \left(\frac{hl}{h+l} \right)$ (D) $\frac{M+m}{M} \left(\frac{hl}{h+l} \right)$

120. In the arrangement shown, if the blocks A and B move towards each other with acceleration values a and b , respectively, then acceleration of the block C is

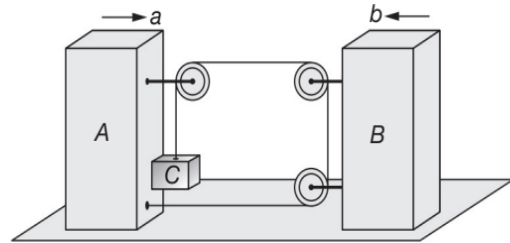

- (A) $2a + 2b$ (B) $\sqrt{4a^2 + 5b^2 + 8ab}$
 (C) a (D) $\sqrt{5a^2 + 4b^2 + 8ab}$

121. A car starts from rest to cover a distance s . The coefficient of friction between the road and the tyres is μ . The minimum time in which the car can cover the distance s is proportional to

- (A) $\frac{1}{\mu}$ (B) $\frac{1}{\sqrt{\mu}}$
 (C) μ (D) $\sqrt{\mu}$

122. In the shown arrangement if f_1 , f_2 and T be the frictional forces on 2 kg block, 3 kg block and tension in the string respectively, then their values are



- (A) 2 N, 6 N, 3.2 N
 (B) 2 N, 6 N, 0 N
 (C) 1 N, 6 N, 2 N
 (D) Data insufficient to calculate the required values

123. In the figure given below, if all surface are assumed to be smooth and the force $F = 100$ N. If acceleration of block B of mass 20 kg is a and tension in string connecting block A of mass 20 kg is T then just after when the force F is applied

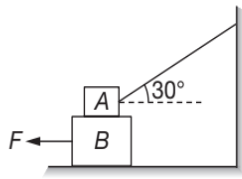

- (A) $T = 0$ and $a = 5 \text{ ms}^{-2}$
- (B) $T = 100 \text{ N}$ and $a = 0$
- (C) $T = 200 \text{ N}$ and $a = 5 \text{ ms}^{-2}$
- (D) None of these

124. The block of mass m is placed on a rough horizontal floor and it is pulled by an ideal string as shown by a constant force F . As the block moves towards right the friction force on block

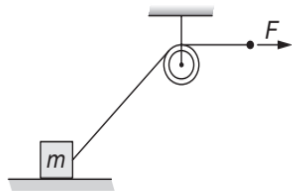

- (A) remains constant
- (B) increases
- (C) decreases
- (D) can be said

125. Two blocks each of mass 20 kg are connected by an ideal string and this system is kept on rough horizontal surface as shown. Initially the string is just tight then a horizontal force $F = 120 \text{ N}$ is applied on one block as shown.

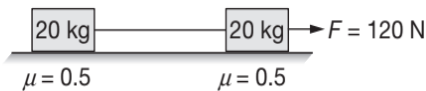

If friction coefficient at every contact is $\mu = 0.5$ then which of the following represents the correct free body diagram.

- (A)
- (B)
- (C)

- (D) All of the above

126. A particle is moving along a circular path with a constant speed. The acceleration of the particle is constant in
- (A) magnitude
 - (B) direction
 - (C) both magnitude and direction
 - (D) neither magnitude nor direction

127. A particle moves in $x-y$ plane. The position vector of particle at any time t is $\vec{r} = [(2t)\hat{i} + (2t^2)\hat{j}] \text{ m}$. The rate of change of θ at time $t = 2 \text{ s}$. (where θ is the angle which its velocity vector makes with positive x -axis) is
- (A) $\frac{2}{17} \text{ rads}^{-1}$
 - (B) $\frac{1}{14} \text{ rads}^{-1}$
 - (C) $\frac{4}{7} \text{ rads}^{-1}$
 - (D) $\frac{6}{5} \text{ rads}^{-1}$

128. Two identical ideal springs of spring constant 1000 Nm^{-1} are connected by a pulley as shown in figure and this arrangement is established in the vertical plane. The pulley is ideal and string passing over pulley is massless. At equilibrium of pulley θ is 60° and the masses m_1 and m_2 are 2 kg and 3 kg , respectively. Then the elongation in each spring when $\theta = 60^\circ$ is

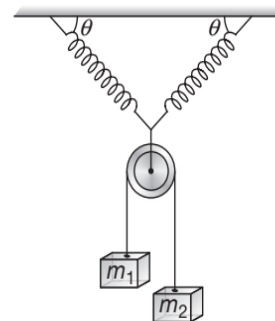

- (A) $1.6\sqrt{3} \text{ cm}$
- (B) 1.6 cm
- (C) 4.8 cm
- (D) None of these

129. A sphere of mass m is held between two smooth inclined walls A and B . For $\sin(37^\circ) = \frac{3}{5}$, the normal reaction of the wall (2) is equal to

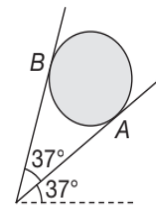

- (A) mg
- (B) $mg \sin(74^\circ)$
- (C) $mg \cos(74^\circ)$
- (D) None of these

130. A block A of mass 2 kg rests on another block B of mass 8 kg which rests on a horizontal floor. The coefficient of friction between A and B is 0.2 while between B and

6.152 JEE Advanced Physics: Mechanics - I

floor is 0.5. When a horizontal force 25 N is applied on B, the frictional force acting between A and B is

- (A) 0 N (B) 3.9 N
(C) 5 N (D) 49 N

131. A block starts moving up a fixed inclined plane of inclination 60° with a velocity of 20 ms^{-1} and stops after 2 s. The approximate value of coefficient of friction is ($g = 10 \text{ ms}^{-2}$)

- (A) 3 (B) 3.3
(C) 0.27 (D) 0.33

132. A point on the periphery of rotating disc has its acceleration vector making an angle 30° with velocity vector then the ratio of magnitude of centripetal acceleration to tangential acceleration is

- (A) $\sin(30^\circ)$ (B) $\cos(30^\circ)$
(C) $\tan(30^\circ)$ (D) None of these

133. Find the only correct statement from the following statements

- (A) A body has a constant velocity and still it can have a varying speed
(B) A body has a constant speed but it can have a varying velocity
(C) A body having constant speed cannot have any acceleration
(D) A body in motion under a force acting upon it must always have work done upon it

134. A smooth sphere of radius R and mass M is placed on the smooth horizontal floor. Another smooth particle of mass m is placed on the sphere and a horizontal force F is applied on the sphere as shown. If the particle does not slip on the sphere then the value of force F is

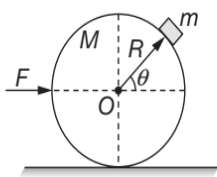

- (A) $F = mg \cot \theta$ (B) $F = Mg \cot \theta$
(C) $F = (m + M)g \cot \theta$ (D) $F = (m + M)g \tan \theta$

135. The contact force exerted by a body on another body is perpendicular to the surfaces in contact. Then,

- (A) the surfaces in contact must be frictionless
(B) the force of friction between the bodies may not be zero
(C) the contact force equals the normal reaction
(D) the contact force equals the friction

136. A rod AB of mass 10 kg tied with a string at C such that $AC = BC$ and rod remains in equilibrium then friction force by horizontal surface will be

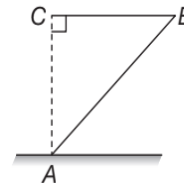

- (A) 50 N towards right (B) 50 N towards left
(C) 100 N (D) None of these

137. A block of mass m is moving on a rough horizontal surface where coefficient of friction between block and surface is $\mu = 0.5$. At $t = 0$, block is moving with a velocity \vec{v} . Then a horizontal force $F = 2t$ is applied on it in the direction of velocity, where t represents time, then the speed of block after the application of force

- (A) decreases
(B) increases
(C) first decreases then increases
(D) first increases then decreases

138. A circular disc of radius $r = 5 \text{ m}$ is rotating in horizontal plane about y -axis. y -axis a vertical axis passing through the centre of disc and x - z is the horizontal plane at ground. The height of disc above ground is $h = 5 \text{ m}$. Small particles are ejecting from disc in horizontal direction with speed 12 ms^{-1} from the circumference of disc then the distance of these particles from origin when they hit x - z plane is

- (A) 5 m (B) 12 m
(C) 13 m (D) None of these

139. A wind farm generator uses a two-bladed propeller mounted on a pylon at a height of 20 m. The length of each propeller blade is 12 m. A tip of the propeller breaks off when the propeller is vertical. At that instant, the period of the motion of the propeller is 1.2 second. The fragment flies off horizontally, falls and strikes the ground at point P.

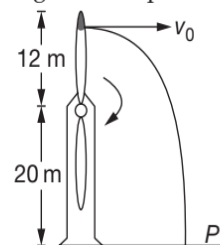

In figure, the distance from the base of the pylon to the point where the fragment strikes the ground is closest to

- (A) 120 m (B) 130 m
(C) 140 m (D) 160 m

140. Two blocks A and B of masses m and $2m$, respectively are held at rest such that the string is in natural length. Find out the accelerations of both the blocks just after release.

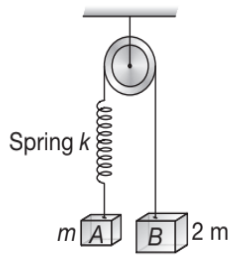

- (A) $g \downarrow, g \downarrow$ (B) $\frac{g}{3} \downarrow, \frac{g}{3} \uparrow$
 (C) $0, 0$ (D) $g \downarrow, 0$

141. In the arrangement shown, the wedge of mass M moves towards left with an acceleration a . All surfaces are smooth. The acceleration of mass m relative to wedge is

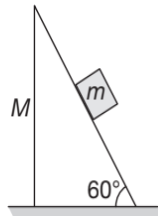

- (A) $\frac{a}{2}$ (B) $\frac{2Ma}{m}$
 (C) $\frac{2(M+m)a}{m}$ (D) $\frac{(M+m)a}{m}$

142. A body A rests on B and friction coefficient between A and B is μ . Block M is placed on a frictionless surface. Then

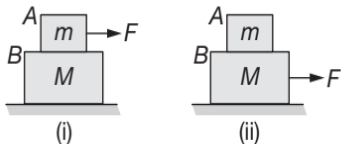

- (A) the maximum possible value of F so that both bodies move together in case (i) is $\mu(m+M)g$
 (B) the maximum possible value of F so that both bodies move together in case (i) is μmg
 (C) the maximum possible value of F so that both bodies move together in case (ii) is $\mu(M+m)g$
 (D) the maximum possible value of F so that both bodies move together in case (ii) is μMg

143. A bicycle is in motion. When it is not pedalled, the force of friction exerted by the ground on two wheels is such that it acts

- (A) in the backward direction on the front wheel and in the forward direction on the rear wheel
 (B) in the forward direction on the front wheel and in the backward direction on rear wheel
 (C) in the backward direction on both the front and the rear wheels
 (D) in the forward direction on both the front and the rear wheels

144. A particle is moving in a circular path and its acceleration vector is making an angle of 30° with the velocity vector, then the ratio of centripetal acceleration to its tangential acceleration is

- (A) $\frac{1}{2}$ (B) $\frac{\sqrt{3}}{2}$
 (C) $\frac{1}{\sqrt{3}}$ (D) $\sqrt{3}$

145. A body is moving in x - y plane as shown in a circular path of radius 2 m . At a certain instant when the body is crossing the positive y -axis its acceleration is $(6\hat{i} - 8\hat{j})\text{ ms}^{-2}$. Then its angular acceleration and angular velocity at this instant will be

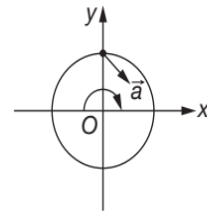

- (A) $-3\hat{k}\text{ rads}^{-2}$ and $-2\hat{k}\text{ rads}^{-1}$ respectively
 (B) $+3\hat{k}\text{ rads}^{-2}$ and $+2\hat{k}\text{ rads}^{-1}$ respectively
 (C) $-4\hat{k}\text{ rads}^{-2}$ and $-\sqrt{3}\hat{k}\text{ rads}^{-1}$ respectively
 (D) $+4\hat{k}\text{ rads}^{-2}$ and $+\sqrt{3}\hat{k}\text{ rads}^{-1}$ respectively

146. A block of mass m is attached to an ideal spring and system lies in vertical plane as shown. Initially the supporting plane is placed so that spring remains in its natural length then the plane is moved very slowly downwards. The graph showing variation of normal reaction applied by mass on supporting plane with distance travelled by block is

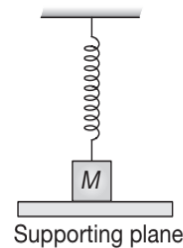

- (A) (B)
 (C) (D) None of these

147. Two identical heavy spheres of equal mass are placed on smooth cup of radius $3r$, where r is radius of each sphere as shown. Then the ratio of reaction

6.154 JEE Advanced Physics: Mechanics - I

force between cup and any sphere to reaction force between two spheres is

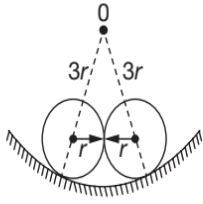

- (A) 1 (B) 2
(C) 3 (D) None of these

148. In the given figure, the coefficient of friction between m_1 and m_2 is μ and m_2 and horizontal surface is zero

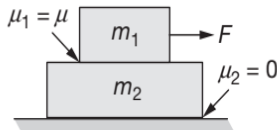

- (A) If $F > \mu m_1 g$, then relative acceleration is found between m_1 and m_2
(B) If $F < \mu m_1 g$, then no relative acceleration is found between m_1 and m_2
(C) If $F > \mu m_1 g$, then both bodies move together
(D) (A) and (B) are correct

149. The force required to just move a body up the inclined plane is double the force required to just prevent the body from sliding down the plane. The coefficient of friction is μ . The inclination θ of the plane is

- (A) $\tan^{-1}(\mu)$ (B) $\tan^{-1}\left(\frac{\mu}{2}\right)$
(C) $\tan^{-1}(2\mu)$ (D) $\tan^{-1}(3\mu)$

150. A circular tube of radius R and cross-sectional radius r ($r \ll R$) is filled completely with iron balls of radius ρ . Iron balls are just fitting into the tubes. The tension in the tube when it is rotated about its axis perpendicular to its plane with angular velocity ω is

- (A) $\frac{4}{3}\pi\rho\omega^2r^3R$ (B) $\frac{4}{3}\pi\rho\omega^2r^2R^2$
(C) $\frac{2}{3}\pi\rho\omega^2r^3R$ (D) $\frac{2}{3}\pi\rho\omega^2r^2R^2$

151. A plumb-line is set up on a rotating disk and makes an angle of α with the vertical, as in figure. The distance r from the point of suspension to the axis of rotation is known, and so is the length l of the thread. The angular velocity of rotation is

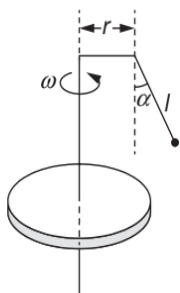

- (A) $\omega = \sqrt{\frac{g \tan \alpha}{r + l \sin \alpha}}$ (B) $\omega = \sqrt{\frac{g \sin \alpha}{r + l \tan \alpha}}$
(C) $\omega = \sqrt{\frac{g}{r + l \sin \alpha}}$ (D) $\omega = \sqrt{\frac{g \cos \alpha}{r + l \sin \alpha}}$

152. The force exerted by the ideal string on the ideal pulley P is

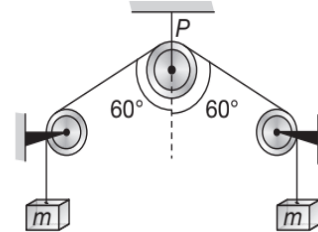

- (A) mg (B) $2mg$
(C) $\sqrt{2}mg$ (D) $4mg$

153. A rope of mass M is hanged from two supports A and B as shown in figure. Maximum and minimum tension in the rope respectively are

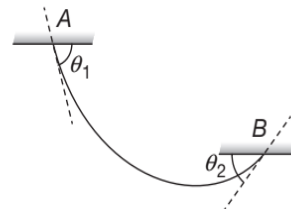

- (A) $\frac{Mg \cos \theta_2}{\sin(\theta_1 + \theta_2)}$, $\frac{Mg \cos \theta_1}{\sin(\theta_1 + \theta_2)}$
(B) Mg , $Mg \cos \theta_1$
(C) $\frac{Mg \cos \theta_2}{\sin(\theta_1 + \theta_2)}$, $\frac{Mg \cos \theta_1 \cos \theta_2}{\sin(\theta_1 + \theta_2)}$
(D) $\frac{Mg \cos \theta_2}{\cos(\theta_2 - \theta_1)}$, $\frac{Mg \cos \theta_1}{\sin(\theta_1 + \theta_2)}$

154. Three blocks are arranged as shown in which $ABCD$ is a horizontal plane. Strings are massless and both pulley stands vertical while the strings connecting blocks m_1 and m_2 are also vertical and are perpendicular to faces AB and BC which are mutually perpendicular to each other. If m_1 and m_2 are 3 kg and 4 kg respectively. Coefficient of friction between the block $m_3 = 10$ kg and surface is $\mu = 0.6$, then, frictional force on m_3 is

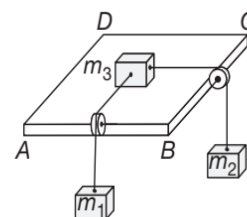

- (A) 30 N (B) 40 N
(C) 50 N (D) 60 N

155. A block A is placed over a long rough plank B of same mass as shown in figure. The plank is placed over a smooth horizontal surface. At time $t = 0$, block A is given a velocity v_0 in horizontal direction. Let v_1 and v_2 be the velocities of A and B at time t . Then choose the correct graph between v_1 or v_2 and t

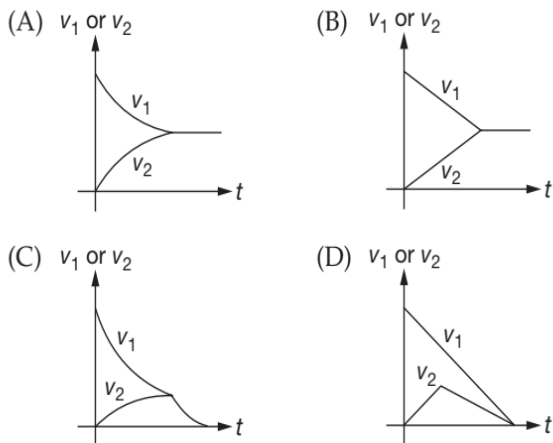
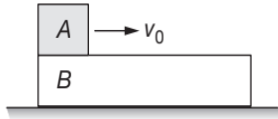

156. Which of the following correctly describes the centripetal acceleration vector for a particle moving in a circular path?
- (A) Constant and always perpendicular to the velocity vector for the particle
 (B) Constant and always parallel to the velocity vector for the particle
 (C) Of constant magnitude and always perpendicular to the velocity for the particle
 (D) Of constant magnitude and always parallel to the velocity vector for the particle

157. A string of length L is fixed at one end and carries a mass M at the other end. The string makes $\frac{2}{\pi}$ revolutions per second around the vertical axis through the fixed end as shown in the figure, then tension in the string is

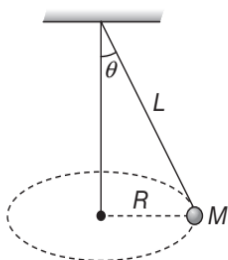

- (A) ML (B) $2ML$
 (C) $4ML$ (D) $16ML$

158. A block of mass m is slipping down a rough inclined wedge kept at rest on a horizontal table, with constant velocity. Force on wedge by the table is

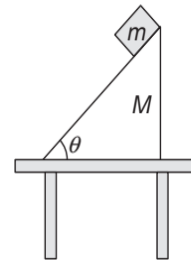

- (A) less than $(m + M)g$
 (B) equal to $(m + M)g$
 (C) equal to $(M + m \cos^2 \theta)g$
 (D) will make some non-zero angle with vertical direction

159. All surface are frictionless and pulley and strings are light. Acceleration of block of mass m is

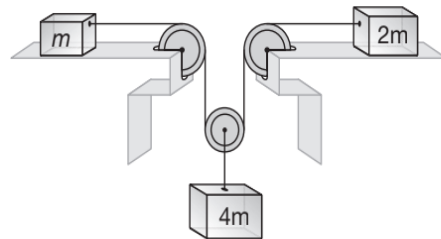

- (A) $\frac{2}{5}g$ (B) $\frac{4g}{5}$
 (C) $\frac{4g}{7}$ (D) $\frac{2g}{7}$

160. Block A is placed over the block B as shown in figure. Wedge is smooth and fixed. Force of friction on block A is

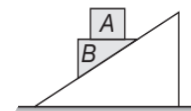

- (A) towards right
 (B) towards left
 (C) zero
 (D) always kinetic

161. A parabolic bowl with its bottom at origin has the shape $y = \frac{x^2}{20}$. Here x and y are in metre. The maximum height at which a small mass m can be placed on the bowl without slipping (coefficient of static friction is 0.5) is

6.156 JEE Advanced Physics: Mechanics - I

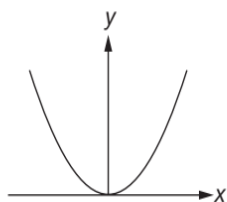

- (A) 2.5 m (B) 1.25 m
(C) 1 m (D) 4 m

162. A particle describes a horizontal circle in a conical funnel whose inner surface is smooth with speed of 0.5 ms^{-1} . The height of the plane of circle from vertex of the funnel is

- (A) 0.25 cm (B) 2 cm
(C) 4 cm (D) 2.5 cm

163. The minimum velocity (in ms^{-1}) with which a car driver must traverse a flat curve of radius 150 m and coefficient of friction 0.6 to avoid skidding is

- (A) 60 (B) 30
(C) 15 (D) 25

164. A bunch of bananas hangs from the end of a rope that passes over a light, frictionless pulley. A monkey of mass equal to the mass of the bananas hangs from the other end of the rope. The monkey and the bananas are initially balanced and at rest. Now the monkey starts to climb up the rope, moving away from the ground with speed v . What happens to the bananas?

- (A) They move downward at speed v
(B) They remain stationary
(C) They move up at speed $\frac{1}{2}v$
(D) They move up at speed v

165. In the given arrangement, strings and pulleys are light and all surface are frictionless. Assuming at $t = 0$, system is released from rest, the speed of block A at $t = 2$ sec is

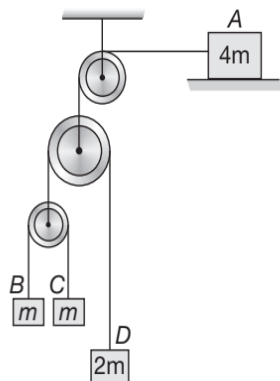

- (A) 8 ms^{-1} (B) 9 ms^{-1}
(C) 10 ms^{-1} (D) None of these

166. A sphere is rotating between two rough inclined walls as shown in Figure.

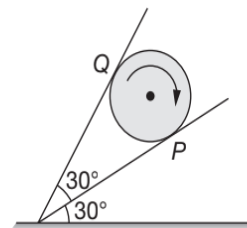

The coefficient of friction between each wall and the sphere is $\frac{1}{3}$. If f_1 and f_2 be the friction forces at P and Q. Then $\frac{f_1}{f_2}$ is

- (A) $\frac{4}{\sqrt{3}} + 1$ (B) $\frac{1}{\sqrt{3}} + 2$
(C) $\frac{1}{2} + \sqrt{3}$ (D) $1 + 2\sqrt{3}$

167. Three blocks A, B and C of equal mass m are placed one over the other on a smooth horizontal ground as shown in figure. Coefficient of friction between any two blocks of A, B and C is $\frac{1}{2}$. The maximum value of mass of block D so that the blocks A, B and C move without slipping over each other is

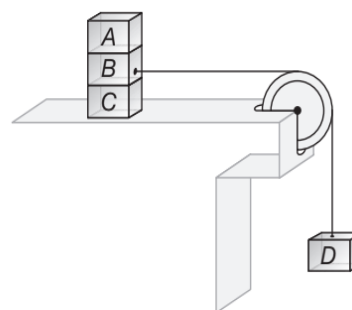

- (A) $6m$ (B) $5m$
(C) $3m$ (D) $4m$

168. A small particle of mass 0.36 g rests on a horizontal turntable at a distance 25 cm from the axis of spindle. The turntable is accelerated at a rate of $\frac{1}{3} \text{ rads}^{-2}$.

The frictional force that the table exerts on the particle 2 s after the start up is

- (A) $40 \mu\text{N}$ (B) $30 \mu\text{N}$
(C) $50 \mu\text{N}$ (D) $60 \mu\text{N}$

169. A block of mass m is placed at the top of a smooth wedge ABC. The wedge is rotated about an axis passing through C as shown in the figure. The minimum value of angular speed ω such that the block does not slip on the wedge is

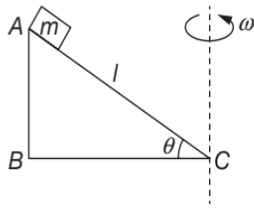

- (A) $\left(\sqrt{\frac{g \sin \theta}{l}}\right) \sec \theta$ (B) $\left(\sqrt{\frac{g}{l}}\right) \cos \theta$
 (C) $\left(\sqrt{\frac{g}{l \cos \theta}}\right) \cos \theta$ (D) $\sqrt{\frac{g \sin \theta}{l}}$

170. Assuming all the surfaces to be frictionless, the acceleration of block C shown in the figure is

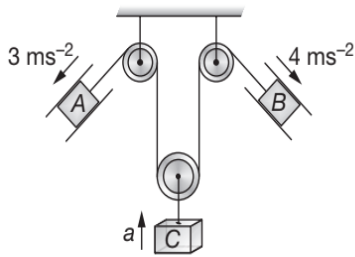

- (A) 5 ms^{-2} (B) 7 ms^{-2}
 (C) 3.5 ms^{-2} (D) 4 ms^{-2}

171. In the figure a smooth pulley of negligible weight is suspended by a spring balance. Weights of 1 kg and 5 kg are attached to the opposite ends of a string passing over the pulley and move with acceleration because of gravity. During the motion, the spring balance reads a weight of

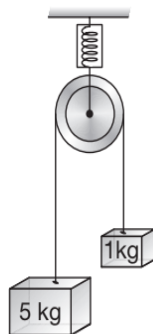

- (A) 6 kg
 (B) less than 6 kg
 (C) more than 6 kg
 (D) may be more or less than 6 kg

172. A wedge of mass $2m$ and a cube of mass m are shown in figure. Between cube and wedge, there is no friction. The minimum coefficient of friction between wedge and ground so that wedge does not move is

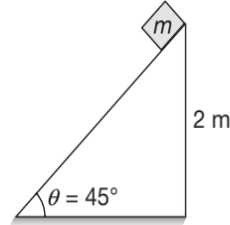

- (A) 0.10 (B) 0.20
 (C) 0.25 (D) 0.50

173. In the figure, $m_A = 2 \text{ kg}$ and $m_B = 4 \text{ kg}$. The minimum value of F for which A starts slipping over B is ($g = 10 \text{ ms}^{-2}$)

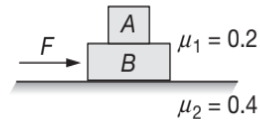

- (A) 24 N (B) 36 N
 (C) 12 N (D) 20 N

174. Two particles starting from a point on a circle of radius 4 m in horizontal plane move along the circle with constant speeds of 4 ms^{-1} and 6 ms^{-1} respectively in opposite directions. The particles will collide with each other after a time of

- (A) 3 s (B) 2.5 s
 (C) 2 s (D) 1.5 s

175. The mass M of the hanging block in figure which will prevent the smaller block from slipping over the triangular block (assuming all the surfaces to be frictionless and the strings and the pulleys to be light) is

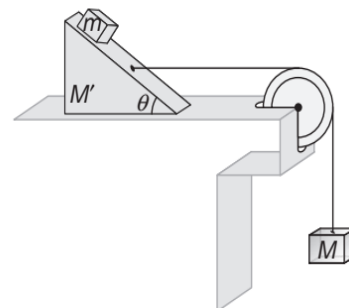

- (A) $\frac{M' + m}{\tan \theta}$ (B) $(M' + m) \tan \theta$
 (C) $\frac{M' + m}{1 - \tan \theta}$ (D) $\frac{M' + m}{\cot \theta - 1}$

6.158 JEE Advanced Physics: Mechanics - I

176. In the figures, shown which of the system is at rest.

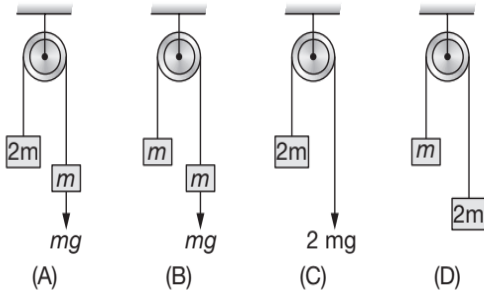

- (A) A only (B) A and C only
(C) A, B, and C only (D) C only

177. One end of the rope is fixed to vertical wall and other end is pulled by horizontal force of 20 N. The shape of flexible rope is shown in figure. The mass of rope is

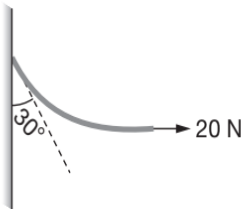

- (A) 2 kg (B) 3 kg
(C) 3.5 kg (D) 4.5 kg

178. A body of mass M is kept on a rough horizontal surface (friction coefficient $= \mu$). A person is trying to pull the body by applying a horizontal force but the body is not moving. The force by the surface on A is F , where

- (A) $F = Mg$
(B) $F = \mu Mg$
(C) $Mg \leq F \leq Mg\sqrt{1+\mu^2}$
(D) $Mg \geq F \geq Mg\sqrt{1-\mu^2}$

179. For the arrangement shown in figure, the tension in the string to prevent it from sliding down is

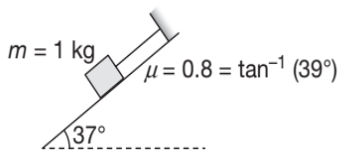

- (A) 6 N (B) 6.4 N
(C) 0.4 N (D) None of these

180. A chain of length $\frac{3}{2}\pi R$ and mass m is put on a mounted half cylinder as shown in figure. Chain is pulled by vertically downward force $2mg$. Assuming the surface to be frictionless, acceleration of chain is

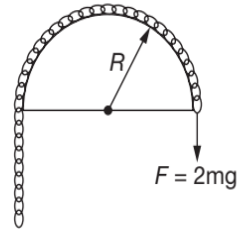

- (A) $2g$ (B) $\frac{2g}{3}$
(C) $\frac{g}{2}$ (D) $\frac{5g}{3}$

181. Which of the following quantities are independent of reference frame Chosen. (Consider classical mechanics only)

- (A) Force
(B) Acceleration
(C) Total energy of an isolated system
(D) None of these

182. The wheel has weight W . The minimum value of F required to pull the wheel up the step is

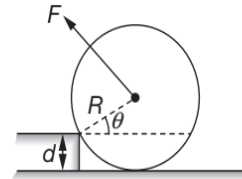

- (A) $W \cos \theta$ (B) $W \tan \theta$
(C) $W \sin \theta$ (D) $W \cot \theta$

183. In the arrangement shown in figure. There is a friction force between the block of masses m and $2m$. Block of mass $2m$ is kept on a smooth horizontal plane. The mass of suspended block is m . Block A is stationary with respect to block of mass $2m$. The minimum value of coefficient of friction between m and $2m$ is

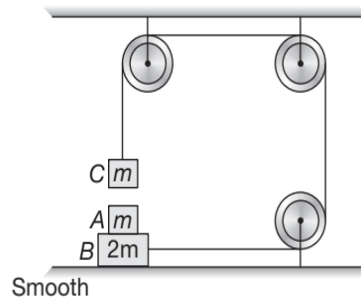

- (A) $\frac{1}{2}$ (B) $\frac{1}{\sqrt{2}}$
(C) $\frac{1}{4}$ (D) $\frac{1}{3}$

184. Two blocks A and B of mass 2 kg and 4 kg are placed one over the other. A horizontal force $F = 2t$, which varies with time is applied on the upper block. If coefficient of friction between blocks A and B is 0.5 and horizontal surface is smooth. Then assuming t is in seconds, the total time upto which both blocks will move together without slipping over each other is

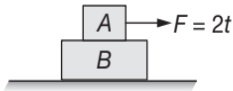

- (A) 5 sec (B) 7.5 sec
(C) 10 sec (D) 12.5 sec

185. A smooth ring of mass M is threaded on a string as shown in the figure. Various portions of strings are vertical. If the ring alone is to remain at rest, then

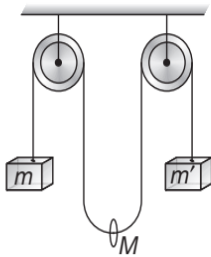

- (A) $\frac{4}{M} = \frac{1}{m} + \frac{1}{m'}$ (B) $\frac{2}{M} = \frac{1}{m} + \frac{1}{m'}$
(C) $\frac{1}{M} = \frac{1}{m} + \frac{1}{m'}$ (D) $\frac{3}{M} = \frac{1}{m} + \frac{1}{m'}$

186. Two monkeys of masses 5 kg and 4 kg are moving along a vertical rope, the former climbing up with an acceleration of 2 ms^{-2} while the later coming down with a uniform velocity of 2 ms^{-1} . Tension in the rope at the fixed support is

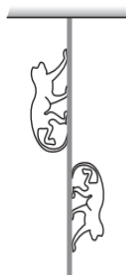

- (A) 80 N (B) 100 N
(C) 98 N (D) 108 N

187. Two blocks of masses m_1 and m_2 are placed in contact with each other on a horizontal platform. The coefficient of friction between the platform and the two blocks is the same. The platform moves with an acceleration. The force of interaction between the blocks is

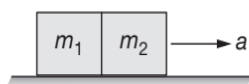

- (A) zero in all cases
(B) zero only if $m_1 = m_2$
(C) nonzero only if $m_1 > m_2$
(D) nonzero only if $m_1 < m_2$

188. A bead of mass m is located on a parabolic wire with its axis vertical and vertex directed towards downward as in figure and whose equation is $x^2 = ay$. If the coefficient of friction is μ , the highest distance above the x -axis at which the particle will be in equilibrium is

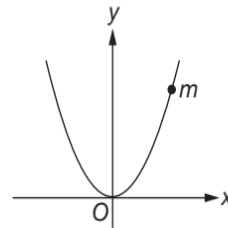

- (A) μa (B) $\mu^2 a$
(C) $\frac{1}{4}\mu^2 a$ (D) $\frac{1}{2}\mu a$

189. In the figure, the wedge is accelerated to the left with an acceleration of $10\sqrt{3}\text{ ms}^{-2}$. It is seen that the block starts climbing upon the smooth inclined face of wedge. The time taken by the block to reach the top if length of the incline is 1.25 m is

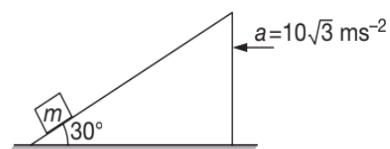

- (A) 2 s (B) 1 s
(C) $\frac{1}{\sqrt{2}}$ s (D) $\frac{1}{2}$ s

190. A body is thrown up in a lift with a velocity 5 ms^{-1} relative to the lift and the time of flight is found to be 0.8 sec . The acceleration with which the lift is moving up will be ($g = 10\text{ ms}^{-2}$)

- (A) 1.5 ms^{-2} (B) 2 ms^{-2}
(C) 2.5 ms^{-2} (D) 3 ms^{-2}

191. A person of 50 kg stands on a 25 kg platform. He pulls on the rope which is attached to the platform via the frictionless pulleys as shown in the figure. The platform moves upwards at a constant velocity if the force with which the person pulls the rope is

6.160 JEE Advanced Physics: Mechanics - I

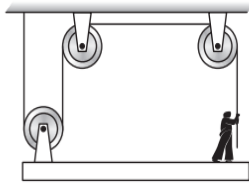

- (A) 500 N (B) 250 N
(C) 25 N (D) 50 N

192. Three identical blocks are suspended on two identical springs one below the other as shown in figure. If thread is cut that supports block 1, then initially (choose one alternative only)

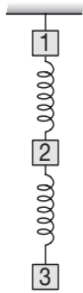

- (A) the second block falls with zero acceleration
(B) the first block falls with maximum acceleration
(C) both (A) and (B) are wrong
(D) both (A) and (B) are correct

193. A particle of mass m is released from point A on smooth fixed circular track as shown. If the particle is released from rest at $t = 0$, then variation of normal reaction N with (θ) angular displacement from initial position is

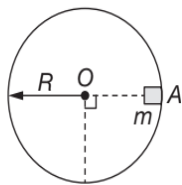

- (A) (B)
(C) (D)

194. A L shaped rod whose one rod is horizontal and other is vertical is rotating about a vertical axis as shown with angular speed ω . The sleeve shown in figure has mass m and friction coefficient between rod and sleeve is μ . The minimum angular speed ω for which sleeve cannot sleep on rod is

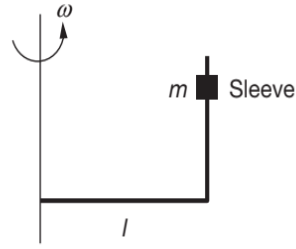

- (A) $\omega = \sqrt{\frac{g}{\mu l}}$ (B) $\omega = \sqrt{\frac{\mu g}{l}}$
(C) $\omega = \sqrt{\frac{l}{\mu g}}$ (D) None of these

195. A bullet moving with a velocity of 100 ms^{-1} can just penetrate two planks of equal thickness. The number of such planks penetrated by the same bullet, when the velocity is doubled, will be

- (A) 4 (B) 6
(C) 8 (D) 10

196. In the given arrangement, n number of equal masses are connected by strings of negligible masses. The tension in the string connected to n th mass is

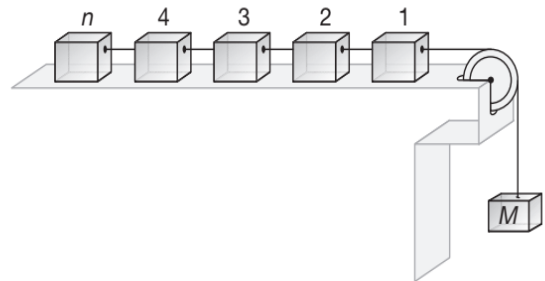

- (A) $\frac{mMg}{nm + M}$ (B) $\frac{mMg}{nmM}$
(C) mg (D) mng

197. A chain consisting of 5 links each of mass 0.1 kg is lifted vertically with a constant acceleration of 2.5 ms^{-2} . The force of interaction between the top link and the link immediately below it, will be

- (A) 6.15 N (B) 4.92 N
(C) 3.69 N (D) 2046 N

198. A ball of mass 400 g is dropped from a height of 5 m . A boy on the ground hits the ball vertically upwards with a bat with an average force of 100 N so that it attains a vertical height of 20 m . The time for which the ball remains in contact with the bat is ($g = 10 \text{ ms}^{-2}$)

- (A) 0.12 sec (B) 0.08 sec
(C) 0.04 sec (D) 12 sec

199. A uniform chain of length L has one of its ends attached to the wall at point A , while $\frac{3L}{4}$ of the length of chain is lying on table as shown in figure. The minimum coefficient of friction between table and chain, so that chain remains in equilibrium is

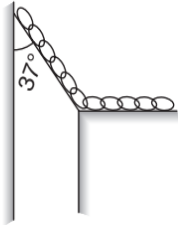

- (A) $\frac{1}{3}$ (B) $\frac{1}{4}$
 (C) $\frac{3}{4}$ (D) $\frac{1}{5}$

200. A block is resting on a horizontal plate in the XY plane and co-efficient of friction between block and the plate is μ . The plate begins to move with velocity $v = bt^2$ in X -direction. At what time will the block starts sliding from plate



- (A) $\frac{\mu b}{g}$ (B) $\frac{\mu b g}{2}$
 (C) $\frac{\mu g}{b}$ (D) $\frac{\mu g}{2b}$

201. 80 railway wagons all of same mass 5×10^3 kg are pulled by an engine with a force of 4×10^5 N. The tension in the coupling between 30th and 31st wagon from the engine is
- (A) 25×10^4 N (B) 20×10^4 N
 (C) 32×10^4 N (D) 40×10^4 N

202. A rod of length L and mass M is acted on by two unequal forces F_1 and $F_2 (< F_1)$ as shown in the following figure. The tension in the rod at a distance y from the end A is given by

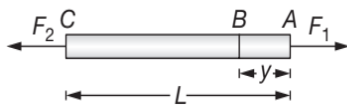

- (A) $F_1 \left(1 - \frac{y}{L}\right) + F_2 \left(\frac{y}{L}\right)$ (B) $F_2 \left(1 - \frac{y}{L}\right) + F_1 \left(\frac{y}{L}\right)$
 (C) $(F_1 - F_2) \frac{y}{L}$ (D) $(F_1 - F_2) \frac{y}{2L}$

203. A disk of mass 10 g is kept floating horizontally in the air by firing bullets each of mass 5 g with the same velocity. If 10 bullets are fired per second and the bullets rebound with the same speed, then the velocity of each bullet is

- (A) 196 cms^{-1} (B) 98 cms^{-1}
 (C) 49 cms^{-1} (D) None of these

204. A particle of mass 2 kg is initially at rest. A force acts on it whose magnitude changes with time. The force time graph is shown below. The velocity of the particle after 10 s is

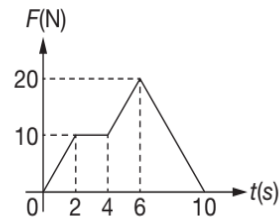

- (A) 20 ms^{-1} (B) 10 ms^{-1}
 (C) 75 ms^{-1} (D) 50 ms^{-1}

205. A body is moving down a long inclined plane of slope 37° . The coefficient of friction between the body and plane varies as $\mu = 0.3x$, where x is the distance travelled down the plane. The body will have maximum speed at

(Given that $\sin(37^\circ) = \frac{3}{5}$ and $g = 10 \text{ ms}^{-2}$)

- (A) $x = 1.16 \text{ m}$ (B) $x = 2 \text{ m}$
 (C) the bottom of plane (D) $x = 2.5 \text{ m}$

206. A 60 kg body is pushed with just enough force to start it moving across a floor and the same force continues to act afterwards. The coefficient of static friction and sliding friction are 0.5 and 0.4 respectively. The acceleration of the body is

- (A) 6 ms^{-2} (B) 4.9 ms^{-2}
 (C) 3.92 ms^{-2} (D) 1 ms^{-2}

207. n -blocks of different masses are placed on the frictionless inclined plane in contact. They are released at the same time. The force of interaction between $(n-1)$ th and n th block is

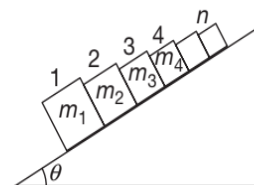

6.162 JEE Advanced Physics: Mechanics - I

- (A) $(m_{n-1} - m_n)g \sin \theta$
- (B) zero
- (C) $mng \cos \theta$
- (D) None of these

208. A rocket of mass 120 kg is fired in the gravity free space. It ejects gases with velocity 600 ms^{-1} at the rate of 1 kgs^{-1} . What will be the initial acceleration of the rocket?

- (A) 1 ms^{-2}
- (B) 5 ms^{-2}
- (C) 10 ms^{-2}
- (D) 15 ms^{-2}

209. In order to raise a mass of 100 kg, a man of mass 60 kg fastens a rope to it and passes the rope over a smooth pulley. He climbs the rope with an acceleration $\frac{5g}{4}$ relative to the rope. The tension in the rope

is ($g = 10 \text{ ms}^{-2}$)

- (A) 1432 N
- (B) 928 N
- (C) 1218 N
- (D) 642 N

210. A U-shaped smooth wire has a semicircular bending between A and B as shown in the figure. A bead of mass m moving with uniform speed v through the wire enters the semicircular bend at A and leaves at B. The average force, exerted by the bead on the part AB of the wire is

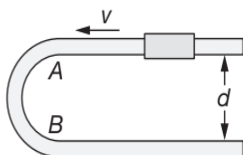

- (A) 0
- (B) $\frac{4mv^2}{\pi d}$
- (C) $\frac{2mv^2}{\pi d}$
- (D) None of these

211. A suitcase is gently dropped on a conveyor belt moving at 3 ms^{-1} . If the coefficient of friction between the belt and the suitcase is 0.5, find the displacement of the suitcase relative to conveyor belt before the slipping between the two is stopped ($g = 10 \text{ ms}^{-2}$)

- (A) 2.7 m
- (B) 1.8 m
- (C) 0.9 m
- (D) 1.2 m

212. A gramophone record is revolving with an angular velocity ω . A coin is placed at a distance R from the centre of the record. The static coefficient of friction is μ . The coin will revolve with the record if

- (A) $R > \frac{\mu g}{\omega^2}$
- (B) $R = \frac{\mu g}{\omega^2}$ only
- (C) $R < \frac{\mu g}{\omega^2}$
- (D) $R \leq \frac{\mu g}{\omega^2}$

213. A plank is held at an angle α to the horizontal (figure) on two fixed supports A and B. The plank can slide against the supports (without friction) because of its weight Mg . Acceleration and direction in which a man of mass m should move so that the plank does not move

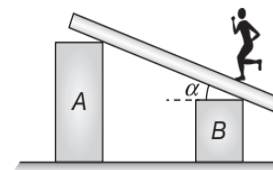

- (A) $g \sin \alpha \left[1 + \frac{m}{M} \right]$ down the incline
- (B) $g \sin \alpha \left[1 + \frac{M}{m} \right]$ down the incline
- (C) $g \sin \alpha \left[1 + \frac{m}{M} \right]$ up the incline
- (D) $g \sin \alpha \left[1 + \frac{M}{m} \right]$ up the incline

214. Given that $m_A = 20 \text{ kg}$, $m_B = 10 \text{ kg}$, $m_C = 20 \text{ kg}$, the coefficient of friction between B and C is $\mu_2 = 0.3$ and that between C and ground $\mu_3 = 0.1$. The least horizontal force F to start the motion of any part of the system of three blocks resting upon one another as shown in figure is ($g = 10 \text{ ms}^{-2}$)

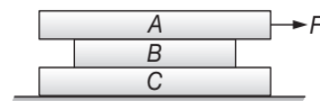

- (A) 60 N
- (B) 90 N
- (C) 80 N
- (D) 50 N

215. Two blocks A and B each of mass m are placed on a smooth horizontal surface. Two horizontal force F and $2F$ are applied on the 2 blocks A and B respectively as shown in figure. The block A does not slide on block B. Then the normal reaction acting between the two blocks is

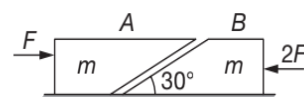

- (A) F (B) $\frac{F}{2}$
 (C) $\frac{F}{\sqrt{3}}$ (D) $3F$

216. Two trolleys 1 and 2 are moving with acceleration a_1 and a_2 respectively in the same direction. A block of mass m on trolleys 1 is in equilibrium from the frame of observer stationary w.r.t. trolleys 2. The magnitude of friction on block due to trolley is

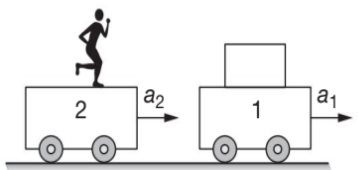

- (A) $m(a_1 - a_2)$ (B) ma_2
 (C) ma_1 (D) None of these

217. A conveyer belt of length l is moving with velocity v . A block of mass m is pushed against the motion of conveyer belt with velocity v_0 from end B with respect to conveyer belt. Co-efficient of friction between block and belt is μ . The value of v_0 so that the amount of heat liberated as a result of retardation of the block by conveyer belt is maximum is

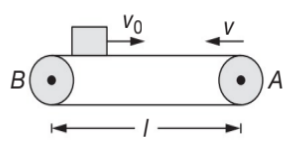

- (A) $\sqrt{\mu gl}$ (B) $\sqrt{2\mu gl}$
 (C) $2\sqrt{\mu gl}$ (D) $\sqrt{3\mu gl}$

218. Assuming that the block always remains horizontal, hence the acceleration of B is

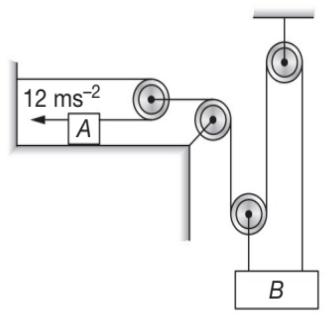

- (A) 6 ms^{-2} (B) 2 ms^{-2}
 (C) 4 ms^{-2} (D) None of these

219. All pulley shown in figure are light and there is no friction between pulley and string. Acceleration of pulley P in figure is given by

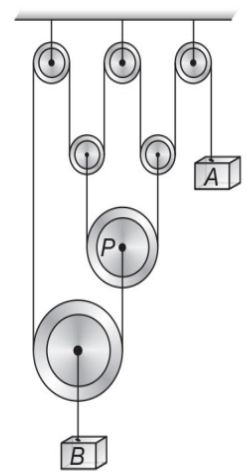

- (A) g upward (B) g downward
 (C) zero (D) None of these

220. The system shown in figure is released from rest. After blocks have moved through a distance $\frac{H}{3}$, collar B stops and blocks A and C continue to move. The speed of C before it hits ground is

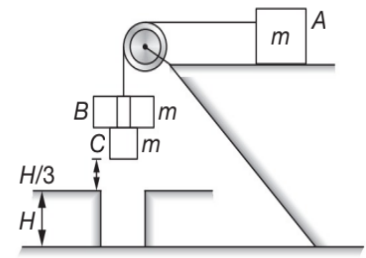

- (A) $\frac{4}{3}\sqrt{gH}$ (B) $2\sqrt{\frac{gH}{3}}$
 (C) $\frac{\sqrt{13gH}}{3}$ (D) $2\sqrt{2gH}$

221. A block A is made to move over an inclined plane of inclination θ with constant acceleration a_0 as shown in figure. Initially bob B hanging from block A is held vertical. Magnitude of acceleration of block A relative to bob immediately after bob is released is

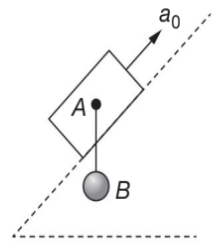

6.164 JEE Advanced Physics: Mechanics - I

- (A) a_0 (B) $a_0 \sin \theta$
 (C) $a_0 \cos \theta$ (D) $(a_0 - g \sin \theta)$

222. The massless string connecting slider A and mass B passes over two small massless smooth pulley, one which is attached to A . The end of strings are attached to mass B and roof as shown. Mass B has constant velocity V_0 directed downwards. At the instant when $Y_A = b$, the magnitude of acceleration of A is

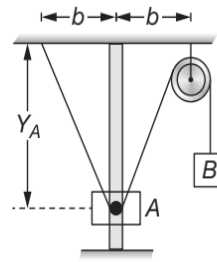

- (A) $\frac{V_0^2}{b}$ (B) $\frac{V_0^2}{2b}$
 (C) $\frac{V_0^2}{4b}$ (D) None of these

MULTIPLE CORRECT CHOICE TYPE QUESTIONS

This section contains Multiple Correct Choice Type Questions. Each question has four choices (A), (B), (C) and (D), out of which ONE OR MORE is/are correct.

- When a bicycle is in motion, the force of friction exerted by the ground on the two wheels (front and rear) is F_1 and F_2 respectively. Then,
 - F_1 is in backward direction and F_2 is in the forward direction.
 - F_1 is in the forward direction and F_2 is in the backward direction.
 - both F_1 and F_2 are in forward direction.
 - both F_1 and F_2 are in backward direction.
- A reference frame attached to the earth
 - is an inertial frame by definition.
 - cannot be an inertial frame because of revolution of earth round the sun.
 - is an inertial frame because Newton's laws are applicable in this frame.
 - cannot be an inertial frame because of rotation of earth about its own axis.

- Two blocks A and B of the same mass are joined by a light inextensible string and placed on a horizontal surface. An external horizontal force P acts on A . The tension in the string is T . The forces of friction acting on A and B are f_1 and f_2 respectively. The limiting value of f_1 and f_2 is f_0 . When P is gradually increased, then

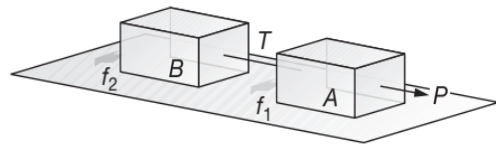

- for $P < f_0$, $T = 0$
- for $f_0 < P < 2f_0$, $T = P - f_0$
- for $P > 2f_0$, $T = \frac{P}{2}$
- None of the above

- A small mirror of area A and mass m is suspended in a vertical plane by a light string. A beam of light of intensity I falls normally on the mirror and the string is deflected from the vertical by an angle θ . Assuming the mirror to be perfectly reflecting we have

- radiation pressure equal to $\frac{2I}{c}$
- radiation pressure equal to $\frac{I}{2c}$
- $\tan \theta = \frac{2IA}{mgc}$
- $\tan \theta = \frac{IA}{2mgc}$

- The maximum value of the force F such that the block shown in the arrangement, does not move is

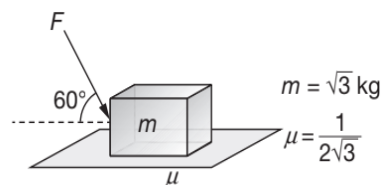

- 20 N
- 10 N
- 12 N
- 15 N

- Two blocks A and B of mass 10 kg and 20 kg, respectively are placed as shown in figure. Coefficient of friction between all the surfaces is 0.2 ($g = 10 \text{ ms}^{-2}$). Then

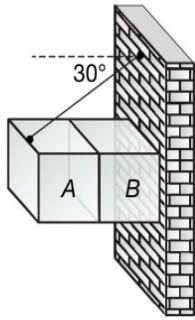

- (A) tension in the string is 306 N
- (B) tension in the string is 132 N
- (C) force exerted by the wall on B is 265 N
- (D) acceleration of block B is 4.7 ms^{-2}

7. Two cubes of masses m_1 and m_2 lie on frictionless slopes of a block A which rests on a horizontal table. The cubes are connected by a string which passes over a pulley as shown in figure. If a_0 be the horizontal acceleration to which the whole system (block + masses) is subjected so that m_1 and m_2 do not move and T be the tension in the string in that situation then find a_0 and T

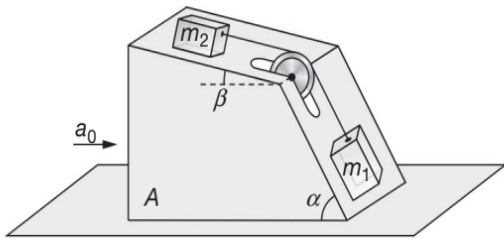

- (A) $a_0 = \left(\frac{m_1 \sin \alpha + m_2 \sin \beta}{m_1 + m_2} \right) g$
- (B) $a_0 = \left(\frac{m_1 \sin \alpha + m_2 \sin \beta}{m_1 \cos \alpha + m_2 \cos \beta} \right) g$
- (C) $T = \frac{m_1 m_2}{m_1 + m_2} g \sin(\alpha + \beta)$
- (D) $T = \left(\frac{m_1 m_2}{m_1 \cos \alpha + m_2 \cos \beta} \right) g \sin(\alpha - \beta)$

8. A block of mass 1 kg is stationary with respect to a conveyor belt that is accelerating with 1 ms^{-2} upwards at an angle of 30° as shown in figure. Which of the following statement(s) is/are correct. ($g = 10 \text{ ms}^{-2}$)

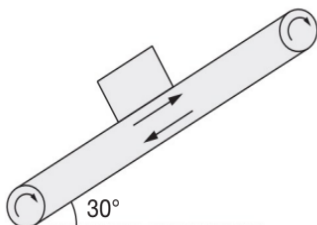

- (A) force of friction on the block is 1 N upwards
- (B) force of friction on the block is 6 N upwards
- (C) contact force between the block and the belt is 10.5 N
- (D) contact force between the block and the belt is $5\sqrt{3}$ N

9. A body is kept on a smooth inclined plane having an inclination of 1 in x . Then,

- (A) slope of inclined plane is $\frac{1}{x}$.
- (B) slope of inclined plane is $\frac{1}{\sqrt{x^2 - 1}}$.
- (C) for the body of mass m to remain stationary relative to the incline, the incline must offer a normal reaction of $mg \frac{x}{\sqrt{x^2 - 1}}$.
- (D) for the body to remain stationary relative to the incline, the incline must be given a horizontal acceleration of $\frac{g}{\sqrt{x^2 - 1}}$.

10. Two blocks A and B of equal mass m are connected through a light inextensible string and arranged as shown in figure. Friction is absent everywhere. When the system is released from rest

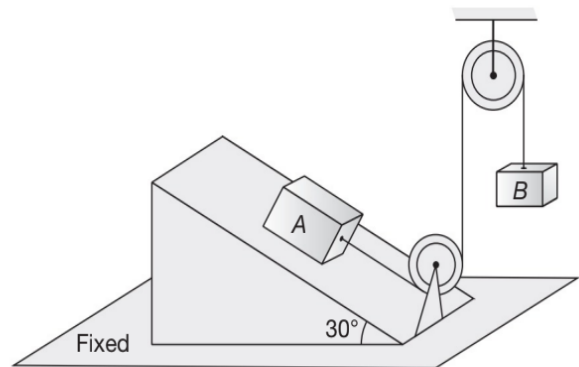

- (A) tension in string is $\frac{mg}{2}$.
- (B) tension in string is $\frac{mg}{4}$.
- (C) acceleration of A is $\frac{g}{2}$.
- (D) acceleration of A is $\frac{3}{4}g$.

11. A block of weight W is suspended from a spring balance. The lower surface of the block rests on a weighing machine. The spring balance reads W_1 and the weighing machine reads W_2 . Assuming all W , W_1 , W_2 to have the same units, which of the following is/are correct?

6.166 JEE Advanced Physics: Mechanics - I

- (A) $W = W_1 + W_2$, when the system is at rest.
- (B) $W > W_1 + W_2$, when the system moves down with some acceleration.
- (C) $W_1 > W_2$, when the system moves up with some acceleration.
- (D) Data is insufficient to find the relation between W_1 and W_2 .

12. A uniform chain of length L lies on a smooth horizontal table with its length perpendicular to the edge of the table and a small portion of the chain is hanging over the edge. The chain starts sliding due to the weight of the hanging part.

- (A) The acceleration of the chain is $\frac{gx}{L}$; where x is the length of the hanging part of chain.
- (B) The acceleration of the chain is $\frac{g}{L}(L-x)$; where x is the length of the hanging part of chain.
- (C) The velocity of the chain is $x\sqrt{\frac{g}{L}}$, where x is the length of the hanging part of chain.
- (D) The velocity of the chain is $(L-x)\sqrt{\frac{g}{L}}$; where x is the length of the hanging part of chain.

13. An amusement park ride called "The Spinning Terror" is a large vertical drum which spins so fast that everyone inside stays pinned against the wall when the floor drops away

- (A) The minimum angular velocity is $\omega_{\min} = \sqrt{\frac{g}{\mu R}}$ for everyone to stay inside.
- (B) The minimum linear velocity is $v_{\min} = \sqrt{\frac{g}{\mu R}}$ for everyone to stay inside.
- (C) The minimum angular velocity is $\omega_{\min} = \sqrt{\frac{gR}{\mu}}$ for everyone to stay inside.
- (D) The minimum linear velocity is $v_{\min} = \sqrt{\frac{gR}{\mu}}$ for everyone to stay inside.

14. In the arrangement shown $W_1 = 200$ N, $W_2 = 100$ N, $\mu = 0.25$ for all surfaces in contact. The block W_1 just slides under the block W_2 .

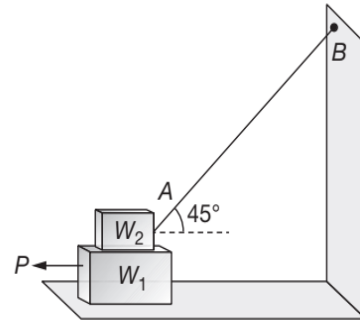

- (A) A pull of 50 N is to be applied on W_1 .
- (B) A pull of 90 N is to be applied on W_1 .
- (C) Tension in the string AB is $10\sqrt{2}$ N.
- (D) Tension in the string AB is $20\sqrt{2}$ N.

15. A weight W can be just supported on a rough inclined plane by a force P either acting along the plane or horizontally. The angle of friction is ϕ and θ is the angle which incline makes with the horizontal.

- (A) The incline makes an angle with the horizontal twice the angle of friction i.e., $\theta = 2\phi$.
- (B) The incline make an angle with the horizontal equal to the angle of friction i.e., $\theta = \phi$.
- (C) The ratio of the force to the weight is $\frac{P}{W} = \cot \phi$.
- (D) The ratio of the force to the weight is $\frac{P}{W} = \tan \phi$.

16. An insect crawls up a hemispherical surface very slowly as shown in figure. The coefficient of friction between the surface and the insect is $\frac{1}{3}$. If the line joining the centre of the hemispherical surface to the insect makes an angle α with the vertical, the maximum possible value of α is given by

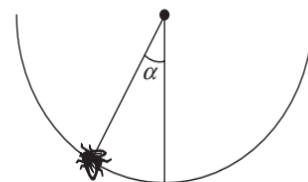

- (A) $\cot \alpha = 3$
- (B) $\tan \alpha = 3$
- (C) $\sec \alpha = 3$
- (D) $\operatorname{cosec} \alpha = 3$

17. A string of negligible mass going over a clamped pulley of mass m supports a block of mass M as shown in the figure. The force on the pulley by the clamp is given by

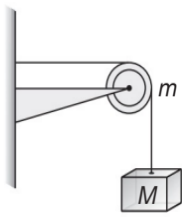

- (A) $\sqrt{2}Mg$
- (B) $\sqrt{2}mg$
- (C) $\sqrt{(M+m)^2 + m^2}g$
- (D) $\sqrt{(M+m)^2 + M^2}g$

18. A boy of mass m kg slides down a light rope attached to a fixed spring balance, with an acceleration a . The reading of the spring balance is M kg.

- (A) The tension in the rope is $T = Mg$ N
- (B) $m = M\left(1 + \frac{a}{g}\right)$
- (C) $m = \frac{Mg}{g-a}$
- (D) The force of friction exerted by the rope on the boy is $f = m(g-a)$ N

19. A block of weight 9.8 N is placed on a table. The table surface exerts an upward force of 10 N on the block. Assume $g = 9.8 \text{ ms}^{-2}$.

- (A) The block exerts a force of 19.8 N on the table.
- (B) The block exerts a force of 10 N on the table.
- (C) The block has an upward acceleration.
- (D) The block exerts a force of 9.8 N on the table.

20. A solid uniform cube of mass m is pressed against a rough vertical wall by applying a force F as shown in the figure. The cube is stationary. Choose the incorrect option

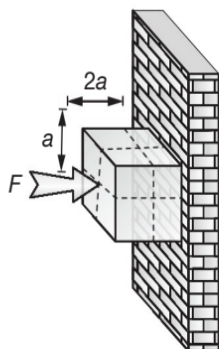

- (A) normal force by the wall on the cube is F
- (B) friction force on the cube is mg

- (C) the torque of force F about the centre of mass of the cube is zero
- (D) the torque of normal force about the centre of mass of the cube is zero

21. Two blocks A and B of mass 4 kg and 2 kg respectively connected by a spring of force constant $k = 100 \text{ Nm}^{-1}$ are placed on an inclined plane of inclination 30° as shown in figure. If the system is released from rest, which one of the following statement(s) is/are correct ($g = 10 \text{ ms}^{-2}$)

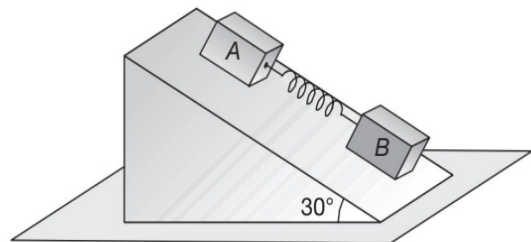

- (A) there will be no compression/elongation in the spring if all surfaces are smooth
- (B) maximum compression of the spring is 10 cm if all surfaces are smooth
- (C) maximum elongation in the spring is 60 cm if all the surfaces are smooth
- (D) there will be elongation in the spring if A is smooth and B is rough

22. Newton's laws are valid in

- (A) any reference frame.
- (B) a reference frame moving with constant velocity with respect to an inertial frame.
- (C) all reference frames which are at rest with respect to an inertial frame.
- (D) the reference frame attached to the earth.

23. A light vertical chain is used to haul up an object of mass M attached to its lower end. The vertical pull applied has a magnitude F at $t=0$ and it decreases at a uniform rate of $f \text{ Nm}^{-1}$ over a distance s through which the object is raised.

- (A) The acceleration of the object is $\left(\frac{F - fy - Mg}{M}\right)$ when the object is raised through a distance $y (< s)$.
- (B) The acceleration of the object is constant.
- (C) The object has a velocity $\sqrt{\frac{2s}{M}\left(F - Mg - \frac{fs}{2}\right)}$ when it has been raised through a distance s .
- (D) The object has a velocity $\sqrt{\frac{s}{g}}$ when it has been raised through a distance s .

6.168 JEE Advanced Physics: Mechanics - I

24. A lift is moving downwards. A body of mass m kept on the floor of the lift is pulled horizontally. If μ is the coefficient of friction between the surfaces in contact then,
- (A) frictional resistance offered by the floor is μmg when lift moves up with a uniform velocity of 5 ms^{-1} .
- (B) frictional resistance offered by the floor is μmg when lift moves up with a uniform velocity of 3 ms^{-1} .
- (C) frictional resistance offered by the floor is $5 m\mu$ when lift accelerates down with an acceleration of 4.8 ms^{-2} .
- (D) frictional resistance (f) offered by the floor must lie in the range $0 \leq f < \infty$.
25. The two blocks A and B of equal mass are initially in contact when released from rest on the inclined plane. The coefficients of friction between the inclined plane and A and B are μ_1 and μ_2 respectively.

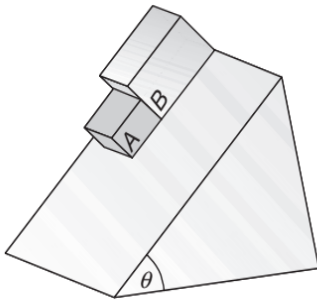

- (A) If $\mu_1 > \mu_2$, the blocks will always remain in contact.
- (B) If $\mu_1 < \mu_2$, the blocks will slide down with different accelerations.
- (C) If $\mu_1 > \mu_2$, the blocks will have a common acceleration $\frac{1}{2}(\mu_1 + \mu_2)g \sin \theta$.
- (D) If $\mu_1 < \mu_2$, the blocks will have a common acceleration $\frac{\mu_1 \mu_2 g}{\mu_1 + \mu_2} \sin \theta$.

26. The pulleys and strings shown in the figure are smooth and of negligible mass. For the system to remain in equilibrium, the angle θ should be

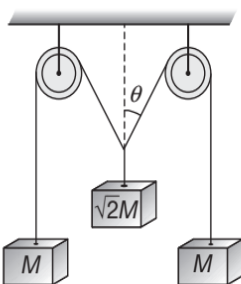

- (A) 0° (B) 30°
 (C) 45° (D) 60°

27. A simple pendulum with a bob of mass m is suspended from the roof of a car moving with a horizontal acceleration a .
- (A) The string makes an angle of $\tan^{-1}\left(\frac{g}{a}\right)$ with the vertical.
- (B) The string makes an angle of $\tan^{-1}\left(\frac{a}{g}\right)$ with the vertical.
- (C) The tension in the string is $m\sqrt{g^2 - a^2}$.
- (D) The tension in the string is $m\sqrt{a^2 + g^2}$.
28. In the arrangement shown in figure pulley is smooth and massless and string is light. Friction coefficient between A and B is μ . Friction is absent between A and plane. Select the correct alternative(s)

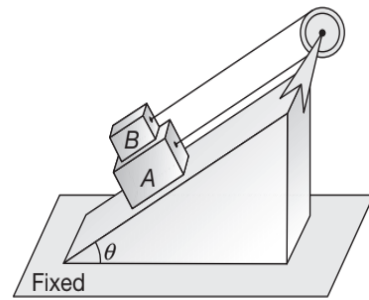

- (A) acceleration of the system is zero if $\mu \geq \left(\frac{m_B - m_A}{2m_B}\right) \tan \theta$ and $m_B > m_A$
- (B) force of friction between A and B is zero if $m_A = m_B$
- (C) B moves upwards if $m_B < m_A$
- (D) tension in the string is $mg \sin \theta$ if $m_A = m_B = m$

29. A block A of mass 500 g is placed on a smooth horizontal table with a light string attached to it. The string passes over a smooth pulley P at the end of the table (as shown) and is connected to other block B of mass 200 g . Initially the block A is at a distance of 200 cm from the pulley and is moving with a speed of 50 cms^{-1} to the left. At $t = 1 \text{ s}$

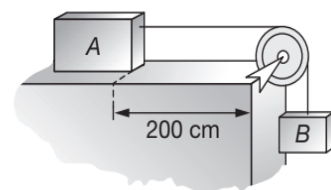

- (A) the block is at a distance of 90 cm from the pulley P .
- (B) the block is at a distance of 110 cm from the pulley P .
- (C) the block has a velocity of 230 cms^{-1} towards left.
- (D) the block has a velocity of 230 cms^{-1} towards right.

30. Two masses m and M ($m < M$) are joined by a light string passing over a smooth and light pulley (as shown).

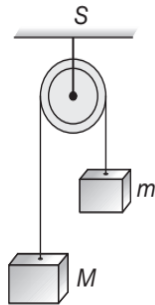

- (A) The acceleration of each mass is $\left(\frac{M-m}{M+m}\right)g$.
- (B) The tension in the string connecting masses is $\left(\frac{2Mm}{M+m}\right)g$.
- (C) The thrust acting on the pulley is $\left(\frac{4Mm}{M+m}\right)g$.
- (D) The centre of mass of the system (i.e. M and m) moves down with an acceleration of $\left(\frac{M-m}{M+m}\right)^2 g$.

31. In the arrangement shown in figure all surfaces are smooth. Select the correct alternative(s)

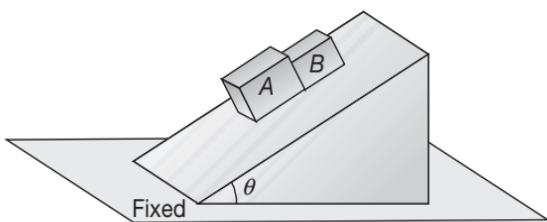

- (A) contact force between the two blocks is zero if $\frac{m_A}{m_B} = \tan \theta$
- (B) for any value of θ acceleration of A and B are equal
- (C) normal reactions exerted by the wedge on the blocks are equal
- (D) contact force between the two is zero for any value of m_A or m_B

32. A cricket ball of mass 150 g is moving with a velocity of 12 ms^{-1} and is hit by a bat so that it turns back with a velocity of 20 ms^{-1} . The force of blow acts for a time of 0.01 s. Then,

- (A) the change in momentum of ball is 4.8 kgms^{-1} .
- (B) the average force exerted by the bat on the ball is 480 N.
- (C) change in momentum of the ball is 1.2 kgms^{-1} .
- (D) the average force exerted by the bat on the ball is 120 N.

33. In the pulley system shown the movable pulleys A , B and C have mass m each, D and E are fixed pulleys. The strings are vertical, light and inextensible. Then,

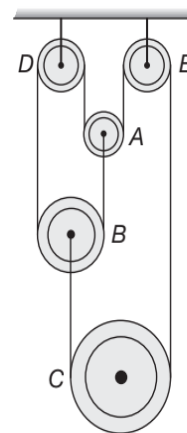

- (A) the tension throughout the string is the same and equals $T = \frac{2mg}{3}$.
- (B) pulleys A and B have acceleration $\frac{g}{3}$ each in downward direction and pulley C has acceleration $\frac{g}{3}$ in upward direction.
- (C) pulleys A , B and C all have acceleration $\frac{g}{3}$ in downward direction.
- (D) pulley A has acceleration $\frac{g}{3}$ in downward direction and pulleys B and C have acceleration $\frac{g}{3}$ each in upward direction.

34. Two masses of 10 kg and 20 kg are connected by a light spring as shown. A force of 200 N acts on a 20 kg mass as shown. At a certain instant the acceleration of 10 kg mass is 12 ms^{-2} .

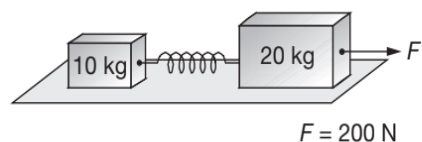

6.170 JEE Advanced Physics: Mechanics - I

- (A) At that instant the 20 kg mass has an acceleration of 12 ms^{-2} .
- (B) At that instant the 20 kg mass has an acceleration of 4 ms^{-2} .
- (C) The stretching force in the spring is 120 N.
- (D) The collective system moves with a common acceleration of 30 ms^{-2} when the extension in the connecting spring is the maximum.

35. A particle is acted upon by a force of constant magnitude which is always perpendicular to the velocity of the particle. The motion of the particle takes place in a plane. It follows that

- (A) its velocity is constant.
- (B) its acceleration is constant.
- (C) its kinetic energy is constant.
- (D) it moves in a circular path.

36. A particle of mass M is moving with acceleration a_0 as measured by an observer 1 standing in a frame of reference moving with a uniform velocity. Another observer 2 is standing in a frame of reference moving with acceleration a .

- (A) Observer 1 measures the force acting on the body as Ma_0 .
- (B) Observer 2 measures the force acting on the body as Ma .
- (C) Observer 2 measures the force acting on the body as $Ma_0 - Ma$.
- (D) Observer 1 is standing in an inertial frame of reference and observer 2 is standing in a non-inertial frame of reference.

37. Two blocks on a rough incline are connected by a light string that passes over a frictionless light pulley as shown. Assuming $m_1 > m_2$ and taking the coefficient of kinetic friction for each block to be μ we get acceleration of the blocks as

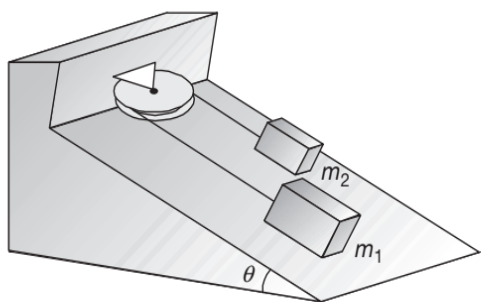

- (A) $a = \frac{[(m_1 - m_2)\sin\theta - \mu(m_1 + m_2)\cos\theta]g}{(m_1 + m_2)}$ for m_1
- (B) $a = \frac{[\mu(m_1 + m_2)\cos\theta - (m_1 - m_2)\sin\theta]g}{(m_1 + m_2)}$ for m_2

- (C) $a = g(\sin\theta - \mu\cos\theta)$
- (D) $a = g(\cos\theta - \mu\sin\theta)$

38. Two masses m_1 and m_2 are connected by a light string which passes over the top of an inclined plane making an angle of 30° with the horizontal such that one mass rests on the plane and other hangs vertically. It is found that m_1 hanging vertically can draw m_2 up the full length of the incline in half the time in which m_2 hanging vertically draws m_1 up the full length of the incline. Assuming the surfaces in contact to be frictionless and pulley to be light and smooth, we have

- (A) the ratio of acceleration in the two cases respectively as 4.
- (B) the ratio of acceleration in the two cases respectively as $\frac{1}{4}$.
- (C) the ratio of masses m_1 and m_2 as $\frac{3}{2}$.
- (D) the ratio of masses m_1 and m_2 as $\frac{2}{3}$.

39. Which of the following statement(s) is (are) correct about friction ?

- (A) The coefficient of friction between two bodies is largely independent of area of contact.
- (B) The frictional force can never exceed the reaction force on a body from the supporting surface.
- (C) Rolling friction is generally smaller than sliding friction.
- (D) Friction is due to irregularities of the surfaces in contact.

40. Two blocks of masses 2.9 kg and 1.9 kg are suspended from a rigid support S by two inextensible wires each of length 1 m as shown in figure. The upper wire has negligible mass and lower wire has a uniform mass of 0.2 kgm^{-1} . The whole system of blocks, wires and support have an upward acceleration of $a_0 = 0.2 \text{ ms}^{-2}$. Taking $g = 9.8 \text{ ms}^{-2}$, we have

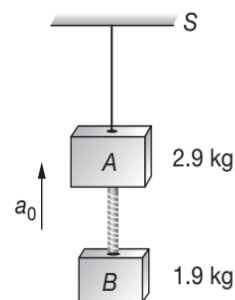

- (A) tension at the midpoint of upper rope is 50 N.
- (B) tension at the midpoint of upper rope is 40 N.

- (C) tension at the midpoint of lower rope is 19.6 N.
- (D) tension at the midpoint of lower rope is 20 N.

41. An engine of mass 5×10^4 kg pulls a coach of mass 4×10^4 kg. A resistance of 1 N per 100 kg is acting on both the coach and the engine and if the driving force of the engine is 4500 N then
- (A) the acceleration of the system (coach + engine) is 0.04 ms^{-2} .
 - (B) the acceleration of the system (coach + engine) is 0.05 ms^{-2} .
 - (C) the tension in the coupling is 2000 N.
 - (D) the tension in the coupling is 2400 N.

42. The spheres A and B as shown have mass M each. The strings SA and AB are light and inextensible with tensions T_1 and T_2 respectively. A constant horizontal force $F = Mg$ is acting on B . For the system to be in equilibrium we have

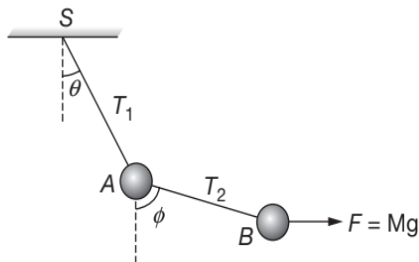

- (A) $\tan \phi = 1$
- (B) $\tan \theta = 0.5$
- (C) $T_2 = \sqrt{2} Mg$
- (D) $T_1 = \sqrt{5} Mg$

43. A person is sitting on a moving train and is facing the engine. He tosses up a coin which falls behind him.
- (A) The train is moving forward and gaining speed.
 - (B) The train is moving forward and losing speed.
 - (C) The train is moving backward and losing speed.
 - (D) The train is moving backward and gaining speed.

44. In the diagram shown, the acceleration of the block B as shown in figure relative to the block A and relative to ground is a_{BA} and a_{BG} , respectively. If the block A is moving toward left with an acceleration a_0 , then

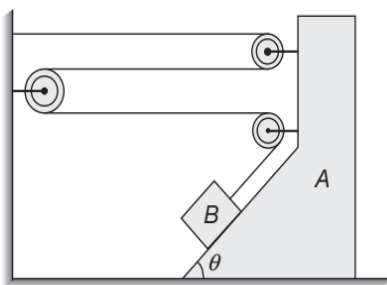

- (A) $a_{BA} = 2a_0$
- (B) $a_{BG} = 3a_0$
- (C) $a_{BG} = 3a_0$
- (D) $a_{BG} = a_0 \sqrt{10 + 6 \cos \theta}$

45. In the adjoining figure if acceleration of M with respect to ground is a , then

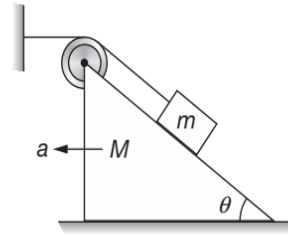

- (A) acceleration of m with respect to M is a .
- (B) acceleration of m with respect to ground is $2a \sin\left(\frac{\alpha}{2}\right)$.
- (C) acceleration of m with respect to ground is a .
- (D) acceleration of m with respect to ground is $a \tan \alpha$.

46. A particle is resting over a smooth horizontal floor. At $t = 0$, a horizontal force starts acting on it. Magnitude of the force increases with time as $F = kt$, where k is a constant. The two curves are drawn for this particle as shown.

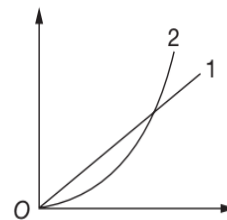

- (A) Curve-1 shows acceleration versus time
- (B) Curve-2 shows velocity versus time
- (C) Curve-2 shows velocity versus acceleration
- (D) None of these

47. A trolley of mass m_1 is to be moved such as to keep block A of mass m_2 at rest with respect to it. A bucket of mass m_3 (with water) in it is placed on trolley. Coefficient of friction between the block A and trolley is μ . The trolley is moved with acceleration so that block does not slip

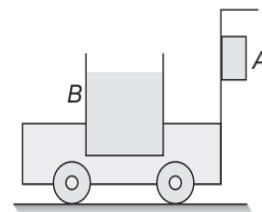

- (A) The minimum coefficient of friction between bucket and trolley is $\frac{\mu}{2}$.
- (B) The acceleration of trolley is $\frac{g}{\mu}$.

6.172 JEE Advanced Physics: Mechanics - I

- (C) The inclination of water surface in the bucket with horizontal in absence of any slipping is $\tan^{-1}\left(\frac{1}{\mu}\right)$.
- (D) Force on trolley is $(m_1 + m_2 + m_3)\frac{g}{\mu}$.

48. Force F is applied on block B and the system is at rest. All surfaces are rough. Which of the following statements is/are correct?

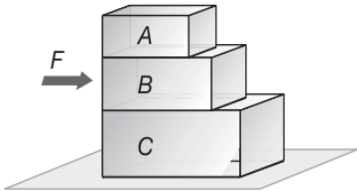

- (A) Friction force on C due to B is zero.
- (B) Friction on C due to ground is equal to friction force on B .
- (C) Friction force on A must be zero.
- (D) Friction force on A depends upon force applied F .
49. Which of the following statements are true for a moving body?
- (A) if its speed changes, its velocity must change and it must have some acceleration
- (B) if its velocity changes, its speed must change and it must have some acceleration
- (C) if its velocity changes, its speed may or may not change, and it must have some acceleration
- (D) if its speed changes, but direction of motion does not change, its velocity may remain constant

50. Speed of a body moving in a circular path changes with time as $v = 2t$, then
- (A) magnitude of acceleration remains constant
- (B) magnitude of acceleration increases
- (C) angle between velocity and acceleration remains constant
- (D) angle between velocity and acceleration increases

51. Two blocks A and B of mass 1 kg each are connected by an ideal string that passes over a smooth pulley that is fixed on a smooth fixed wedge as shown. If the ratio of normal reaction on block A and on block B is $\frac{4}{3}$ then

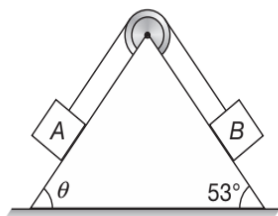

- (A) $\cos\theta = \frac{4}{5}$
- (B) $\sin\theta = \frac{4}{5}$
- (C) acceleration of blocks is $\frac{g}{10}\text{ ms}^{-2}$
- (D) acceleration of blocks is $\frac{g}{5}\text{ ms}^{-2}$

52. Two uniform identical ladders AB and AC each of mass m leans against each other and a string is tied between them which is horizontal. The system stands on a smooth horizontal surface as shown, then, string is connected from ends B and C .

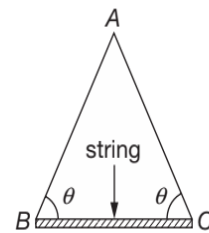

- (A) the force exerted by one rod on other at A is equal to the tension T in the string
- (B) tension in string $T = \left(\frac{mg}{2}\right)\cot\theta$
- (C) tension in string $T = \left(\frac{mg}{2}\right)\tan\theta$
- (D) None of these

53. Two blocks are pushed against a rough wall and the system is at rest as shown in figure. Select the correct statement(s).

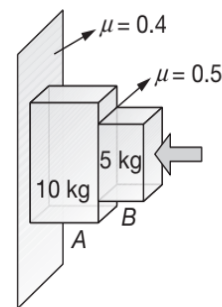

- (A) Friction force on block A due to B is in upward direction
- (B) Friction force on block A due to wall is 150 N
- (C) Minimum force required to keep system at rest is 375 N
- (D) Friction of block B due to A increases with increase in force applied F

54. A block of mass m is moving on a rough horizontal surface and its velocity at time $t = 0$ is found to be \bar{v} then a time varying horizontal force $F = 2t$ is applied

on the body in the direction of its velocity then, after the application of force

- (A) speed of block increases
- (B) first decreases then increases
- (C) work done by friction is negative
- (D) work done by applied force is positive

55. A body moves in a circular path of radius R with deceleration so that at any moment of time its tangential and normal accelerations are equal in magnitude. At the initial moment $t = 0$, the velocity of body is v_0 then the velocity of body will be

- (A) $v = \frac{v_0}{1 + \left(\frac{v_0 t}{R}\right)}$ at time t .
- (B) $v = v_0 e^{-\frac{S}{R}}$ after it has moved S meter.
- (C) $v = v_0 e^{-SR}$ after it has moved S meter.
- (D) None of these

56. A body is moving with constant velocity on the path shown.

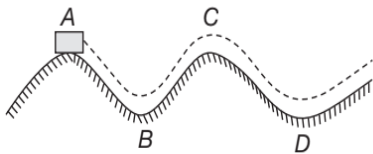

- (A) Normal reaction exerted on body by path is greatest at N_B .
- (B) Normal reaction exerted on body by path is least at N_C .
- (C) Normal force is greater than weight at B .
- (D) Normal force is lesser than weight at A, D .

57. In the figure shown the pulley is ideal and strings are massless. If mass m of hanging block is the minimum mass to keep the system in equilibrium, then ($g = 10 \text{ ms}^{-2}$)

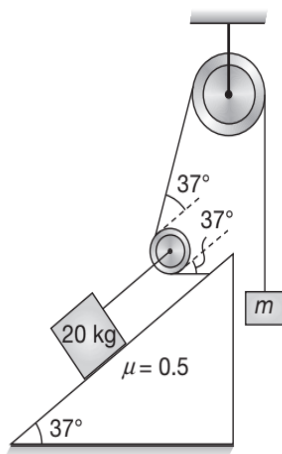

- (A) $m = 2.5 \text{ kg}$
- (B) $m = 5 \text{ kg}$
- (C) force applied by 20 kg block on inclined plane is 179 N
- (D) force applied by 20 kg block on inclined plane is 223 N

58. The blocks ($m_2 > m_1$) are held in such a manner that spring is unstretched initially. Consider the situation at the time of releasing the blocks ($t = 0$) and short time after releasing the blocks ($t > 0$). Acceleration of block of mass m_1 is a_1 and m_2 is a_2 , then

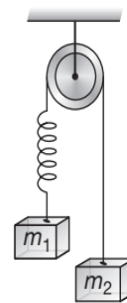

- (A) $t = 0, a_1 = a_2$
- (B) $t = 0, a_1 < a_2$
- (C) $t > 0, a_1 = a_2$
- (D) $t > 0, a_1 < a_2$

59. Three blocks are arranged as shown. $ABCD$ is the horizontal plane. Strings are massless and both pulley stands vertical while the strings connecting blocks m_1 and m_2 are also vertical and perpendicular to each other. The masses m_1 and m_2 are 3 kg and 4 kg respectively. Coefficient of friction between the block $m_3 = 10 \text{ kg}$ and surface is $\mu = 0.6$, then select the correct statement(s).

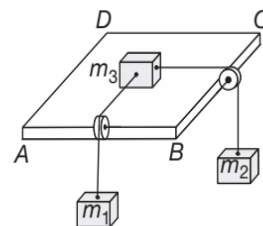

- (A) The system of blocks can be in equilibrium
- (B) At equilibrium frictional force on block m_3 is 60 N
- (C) At equilibrium frictional force on block m_3 is 50 N
- (D) Total force applied by surface on block m_3 is $50\sqrt{5} \text{ N}$

60. Three large box are kept stationary over one other as shown in figure. A horizontal force 20 N acts on middle block as shown in figure. Then select the correct statement(s).

6.174 JEE Advanced Physics: Mechanics - I

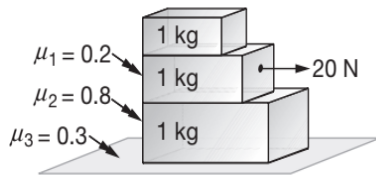

- (A) Acceleration of lowest block is 4.5 ms^{-2} .
 (B) Acceleration of upper most block is 2 ms^{-2} .
 (C) Friction between middle and lower block is 12 N .
 (D) Friction between middle and upper block is 2 N .

61. A car of mass M is moving horizontally on a circular path of radius r . At an instant its speed is v and is increasing at a rate a .

- (A) The acceleration of the car is towards the centre of the path
 (B) The magnitude of the frictional force on the car is greater than $\frac{mv^2}{r}$
 (C) The friction coefficient between the ground and the car is not less than $\frac{a}{g}$
 (D) The friction coefficient between the ground and the car is $\mu = \tan^{-1}\left(\frac{v^2}{rg}\right)$

62. A person applies a constant force \vec{F} on a particle of mass m and finds that the particle moves in a circle of radius r with a uniform speed v as seen (in the plane of motion) from an inertial frame of reference.

- (A) This is not possible
 (B) There are other forces on the particle
 (C) The resultant of the other forces is $\frac{mv^2}{r}$ towards the centre
 (D) The resultant of the other forces varies in magnitude as well as in direction

63. A body of mass 5 kg is suspended by the strings making angles 60° and 30° with the horizontal as shown in figure ($g = 10 \text{ ms}^{-2}$).

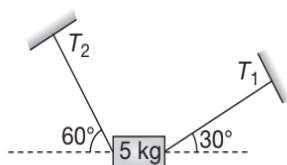

- (A) $T_1 = 25 \text{ N}$ (B) $T_2 = 25 \text{ N}$
 (C) $T_1 = 25\sqrt{3} \text{ N}$ (D) $T_2 = 25\sqrt{3} \text{ N}$

64. In the figure shown, a small block of mass m is kept on M , placed on a horizontal surface. All surfaces are smooth and a force F is applied on M .

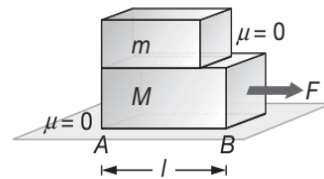

- (A) The acceleration of m w.r.t. ground is $\frac{F}{m}$
 (B) The acceleration of m w.r.t. ground is zero
 (C) The time taken by m to separate from M is $\sqrt{\frac{2lm}{F}}$
 (D) The time taken by m to separate from M is $\sqrt{\frac{2lM}{F}}$

65. A 20 kg block is placed on top of 50 kg block as shown in figure. A horizontal force F acting on A produces an acceleration of 3 ms^{-2} in A and 2 ms^{-2} in B as shown in figure. For this situation mark out the correct statement(s).

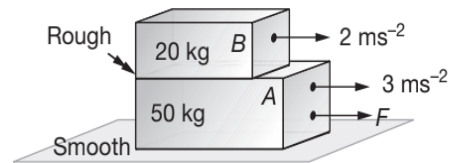

- (A) The friction force between A and B is 40 N .
 (B) The net force acting on A is 150 N .
 (C) The value of F is 190 N .
 (D) The value of F is 150 N .

66. A wedge of mass m_1 and a block of mass m_2 are in equilibrium as shown. Inclined surface of the wedge has an inclination α with the horizontal. Each surface is frictionless. The normal reaction on the wedge may be

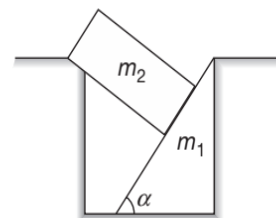

- (A) $m_2 g \cos \alpha$
 (B) $m_2 g \sin \alpha \cos \alpha$
 (C) $m_1 g + m_2 g \cos^2 \alpha$
 (D) $m_1 g + m_2 g \sin \alpha \cos \alpha$

REASONING BASED QUESTIONS

This section contains Reasoning type questions, each having four choices (A), (B), (C) and (D) out of which ONLY ONE is correct. Each question contains STATEMENT 1 and STATEMENT 2. You have to mark your answer as

Bubble (A) If both statements are TRUE and STATEMENT 2 is the correct explanation of STATEMENT 1.

Bubble (B) If both statements are TRUE but STATEMENT 2 is not the correct explanation of STATEMENT 1.

Bubble (C) If STATEMENT 1 is TRUE and STATEMENT 2 is FALSE.

Bubble (D) If STATEMENT 1 is FALSE but STATEMENT 2 is TRUE.

- Statement-1:** Rate of change of linear momentum is equal to external force.
Statement-2: There is equal and opposite reaction to every action.
- Statement-1:** A block of mass m is kept at rest on an inclined plane, the rest force applied by the surface to the block will be mg .
Statement-2: Normal contact force is the resultant of normal contact force and friction force.
- Statement-1:** Friction force always opposes the motion.
Statement-2: Friction force can support the motion.
- Statement-1:** A table cloth can be pulled from a table without disturbing a glass kept on it.
Statement-2: Every body opposes the change in its state.
- Statement-1:** The driver of a moving car sees a wall in front of him. To avoid collision, he should apply brakes rather than taking a turn away from the wall.
Statement-2: Friction force is needed to stop the car or taking a turn on a horizontal road.
- Statement-1:** Two teams having a tug of war always pull equally hard on one another.
Statement-2: The team that pushes harder against the ground, in a tug of war, wins.
- Statement-1:** A bird alights on a stretched wire depressing it slightly. The increase in tension of the wire is more than the weight of the bird
Statement-2: The tension must be more than the weight as it is required to balance weight.
- Statement-1:** Newton's First Law is merely a special case ($a = 0$) of the Second Law.
Statement-2: Newton's First Law defines the frame from where Newton's Second Law; $\vec{F} = m\vec{a}$, \vec{F} representing the net real force acting on a body; is applicable.
- Statement-1:** Two smooth blocks are kept on a smooth inclined plane such that one block is kept over other when a force is applied on upper block acceleration of lower block is unaffected.
Statement-2: Acceleration of a block on smooth inclined plane is $g \sin \theta$.
- Statement-1:** A uniform rope of mass m hangs freely from a ceiling. A monkey of mass M climbs up the rope with an acceleration a . The force exerted by the rope on the ceiling is $M(a + g) + mg$.
Statement-2: Action and reaction force are acting on two different bodies
- Statement-1:** According to Newton's Second Law of motion action and reaction forces are equal and opposite
Statement-2: Action and reaction forces never cancel out each other because they are acting on different objects.
- Statement-1:** Two balls are projected with different velocities at angles 30° and 45° . Horizontal range must be maximum for the ball which is projected at 45° .
Statement-2: For a given velocity $R = \frac{u^2 \sin 2\theta}{g}$.
- Statement-1:** A block of mass m is placed on a smooth inclined plane of inclination θ with the horizontal. The force exerted by the plane on the block has a magnitude $mg \cos \theta$.
Statement-2: Normal reaction always acts perpendicular to the contact surface.
- Statement-1:** A particle is found to be at rest when seen from a frame S_1 and moving with a constant velocity when seen from another frame S_2 . We can say both the frames are inertial.
Statement-2: All frames moving uniformly with respect to an inertial frame are themselves inertial.
- Statement-1:** Coefficient of friction can be greater than unity.
Statement-2: Force of friction is dependent on normal reaction and ratio of force of friction and normal reaction cannot exceed unity.
- Statement-1:** In high jump, it hurts less when an athlete lands on a heap of sand.
Statement-2: Because of greater distance and hence greater time over which the motion of an athlete is stopped, the athlete experience less force when lands on heap of sand.

6.176 JEE Advanced Physics: Mechanics - I

17. **Statement-1:** For a boy it is difficult to run at high speed on a rainy day.

Statement-2: Coefficient of friction μ is decreased due to rain.

18. **Statement-1:** A body in equilibrium has to be at rest only.

Statement-2: A body in equilibrium may be moving with a constant speed along a straight line path.

19. **Statement-1:** Inertia is the property by virtue of which the body is unable to change by itself the state of rest.

Statement-2: The bodies do not change their state unless acted upon by an un-balanced external force.

20. **Statement-1:** Pulling (refer figure 1) is easier than pushing (refer figure 2) on a rough surface.

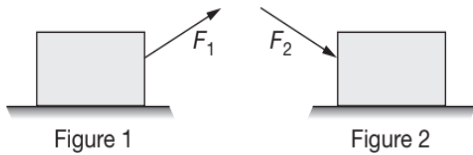

Statement-2: Normal reaction is less in pulling than in pushing.

21. **Statement-1:** A block is lying stationary on an inclined plane and coefficient of friction is μ . Friction on block is $\mu mg \cos \theta$.

Statement-2: Contact force on block is mg .

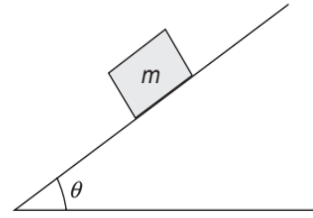

22. **Statement-1:** Static frictional force is always greater than kinetic frictional force.

Statement-2: (Coefficient of static friction) $\mu_s > \mu_k$ (coefficient of kinetic friction).

23. **Statement-1:** Two particles are moving towards each other due to mutual gravitational attraction. The momentum of each particle will increase.

Statement-2: Rate of change of momentum depends upon F_{ext} .

24. **Statement-1:** A concept of pseudo forces is valid both for inertial as well as non-inertial frame of reference.

Statement-2: A frame accelerated with respect to an inertial frame is a non-inertial frame.

25. **Statement-1:** For all bodies, momentum always remains same.

Statement-2: If two bodies of different masses have same momentum the lighter body possesses greater velocity.

LINKED COMPREHENSION TYPE QUESTIONS

This section contains Linked Comprehension Type Questions or Paragraph based Questions. Each set consists of a Paragraph followed by questions. Each question has four choices (A), (B), (C) and (D), out of which only one is correct (For the sake of competitiveness there may be a few questions that may have more than one correct options).

Comprehension I

A rod AB rests with the end A on rough horizontal ground and the end B against a smooth vertical wall. The rod is uniform and of weight W . If the rod is in equilibrium in the position shown in figure. Based on the above facts, answer the following questions.

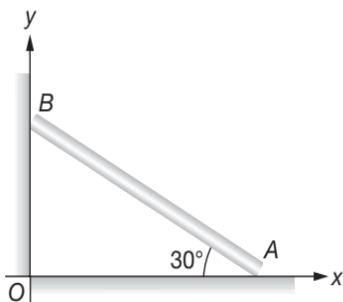

1. The frictional force at A

- (A) $\sqrt{3}W$
- (B) $\frac{\sqrt{3}W}{2}$
- (C) $\frac{\sqrt{3}W}{4}$
- (D) $\frac{\sqrt{3}W}{8}$

2. The normal reaction at A

- (A) W
- (B) $\sqrt{3}W$
- (C) $\frac{\sqrt{3}W}{2}$
- (D) $\frac{\sqrt{3}W}{4}$

3. The normal reaction at B

- (A) $\frac{\sqrt{3}W}{4}$
- (B) $\frac{\sqrt{3}W}{2}$
- (C) $\sqrt{3}W$
- (D) W

Comprehension 2

A 20 kg floodlight in a park is supported at the end of a horizontal beam of negligible mass that is hinged to a pole, as shown in figure. A cable at an angle of 30° with the beam helps to support the light. Based on the above facts, answer the following questions.

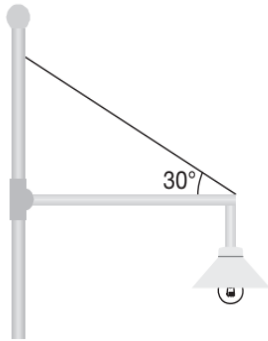

- The tension in the cable is
 (A) 329 N (B) 239 N
 (C) 932 N (D) 392 N
- The horizontal force exerted on the beam by the pole is
 (A) 339 N, left (B) 393 N, left
 (C) 339 N, right (D) 393 N, right
- The vertical force exerted on the beam by the pole is
 (A) zero (B) 196 N, up
 (C) 392 N, down (D) 196 N, down

Comprehension 3

A hemispherical bowl of radius $R = 0.1$ m is rotating about its own axis (which is vertical) with an angular velocity ω . A particle of mass 10^{-2} kg on the frictionless inner surface of the bowl is also rotating with the same ω . The particle is at a height h from the bottom of the bowl. Based on the above facts, answer the following questions.

- The value of ω in terms of h and R is
 (A) $\sqrt{\frac{g}{R}}$ (B) $\sqrt{\frac{g}{h}}$
 (C) $\sqrt{\frac{g}{R+h}}$ (D) $\sqrt{\frac{g}{R-h}}$
- The minimum value of ω needed, in order to have a non-zero value of h
 (A) 8.8 rads^{-1}
 (B) 7.9 rads^{-1}
 (C) 9.9 rads^{-1}
 (D) None of the above seems to be correct

- It is desired to measure g (acceleration due to gravity) using the set-up by measuring h accurately. Assuming that R and ω are known precisely and that the least count in the measurement of h is 10^{-4} m, the minimum possible error Δg in the measured value of g is
 (A) $7.98 \times 10^{-3} \text{ ms}^{-2}$ (B) $9.78 \times 10^{-3} \text{ ms}^{-2}$
 (C) $8.79 \times 10^{-3} \text{ ms}^{-2}$ (D) $9.87 \times 10^{-3} \text{ ms}^{-2}$

Comprehension 4

A smooth semicircular wire track of radius R is fixed in a vertical plane (shown in figure). One end of a massless spring of natural length $\frac{3R}{4}$ is attached to the lowest point O of the wire track. A small ring of mass m which can slide on the track is attached to the other end of the spring. The ring is held stationary at point P such that the spring makes an angle 60° with the vertical. The spring constant is $K = \frac{mg}{R}$. Consider the instant when the ring is making an angle 60° with the vertical. The spring is released. Based on the above facts, answer the following questions.

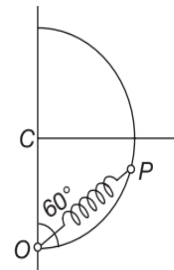

- The free body diagram of the ring for the situation talked is

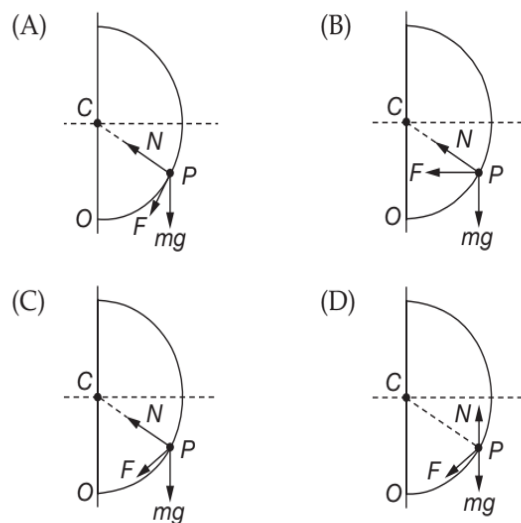

6.178 JEE Advanced Physics: Mechanics - I

11. The tangential acceleration of the ring
- (A) $\frac{\sqrt{3}}{4}g$ (B) $\frac{3\sqrt{3}}{8}g$
- (C) $\frac{\sqrt{3}}{2}g$ (D) $\frac{5\sqrt{3}}{8}g$
12. The normal reaction of the ring
- (A) $\frac{1}{8}mg$ (B) $\frac{1}{4}mg$
- (C) $\frac{3}{8}mg$ (D) $\frac{1}{2}mg$

Comprehension 5

Two blocks of mass $M_1 = 10 \text{ kg}$ and $m_2 = 5 \text{ kg}$ connected to each other by a massless inextensible string of length 0.3 m are placed along a diameter of turn table. The coefficient of friction between the table and m_1 is 0.5 while there is no friction between m_2 and the table. The table is rotating with an angular velocity of 10 rad s^{-1} about a vertical axis passing through its centre O . The masses are placed along the diameter of table on either side of the centre O such that the mass m_1 is at a distance of 0.124 m from O . The masses are observed to be at rest with respect to an observer on the turn table. Based on the above facts, answer the following questions.

13. The frictional force on m_1
- (A) 18 N , outwards (B) 18 N , inwards
- (C) 36 N , outwards (D) 36 N , inwards
14. The minimum angular speed of the turn table, so that the masses will slip from this position
- (A) 12.67 rad s^{-1} (B) 11.67 rad s^{-1}
- (C) 16.27 rad s^{-1} (D) 17.67 rad s^{-1}
15. How should the masses be placed from O with the spring remaining taut so that there is no frictional force acting on the mass m_1 ?
- (A) m_2 at a distance of 0.1 m
- (B) m_1 at a distance of 0.2 m
- (C) m_2 at a distance of 0.2 m
- (D) m_1 at a distance of 0.3 m

Comprehension 6

Block A of mass m and block B of mass $2m$ are placed on a fixed triangular wedge by means of a massless, inextensible string and a frictionless pulley as shown in figure. The wedge is inclined at 45° to the horizontal on both sides. The coefficient of friction between block A and the wedge is $\frac{2}{3}$ and that between block B and the wedge is $\frac{1}{3}$. If the

system A and B is released from rest. Based on the above facts, answer the following questions.

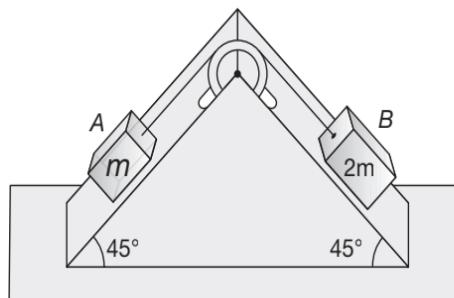

16. The acceleration of A
- (A) $\frac{g}{\sqrt{2}}$ (B) $\frac{g}{\sqrt{3}}$
- (C) $\frac{g}{2}$ (D) zero
17. Tension in the string
- (A) $\frac{\sqrt{2}}{3}mg$ (B) $\frac{2\sqrt{2}}{3}mg$
- (C) $\sqrt{2}mg$ (D) $\frac{4\sqrt{2}}{3}mg$
18. The magnitude and direction of the force of friction acting on A
- (A) $\frac{Mg}{\sqrt{2}}$, down the incline
- (B) $\frac{mg}{2\sqrt{2}}$, up the incline
- (C) $\frac{mg}{3\sqrt{2}}$, down the incline
- (D) $\frac{mg}{3\sqrt{2}}$, up the incline

Comprehension 7

In the figure masses m_1 , m_2 and M are 20 kg , 5 kg and 50 kg respectively. The coefficient of friction between M and ground is zero. The coefficient of friction between m_1 and M and that between m_2 and ground is 0.3 . The pulleys and strings are massless. The string is perfectly horizontal between P_1 and m_1 and also between P_2 and m_2 . The string is perfectly vertical between P_1 and P_2 . An external horizontal force F is applied to the mass M . Let the magnitude of the force of friction between m_1 and M be f_1 and that between m_2 and ground be f_2 . Take $g = 10 \text{ ms}^{-2}$. Based on the above facts, answer the following questions.

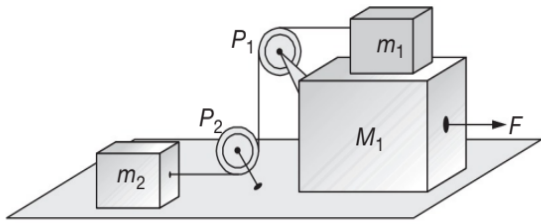

19. A free body diagram of mass M , clearly showing all the forces

(A)

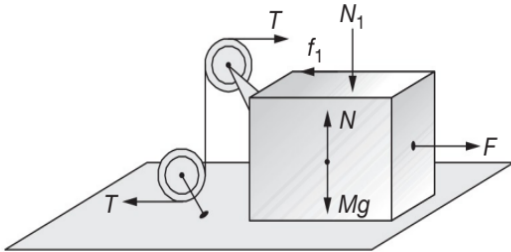

(B)

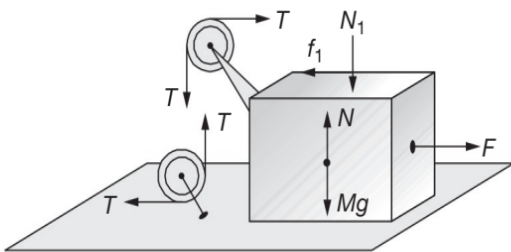

(C)

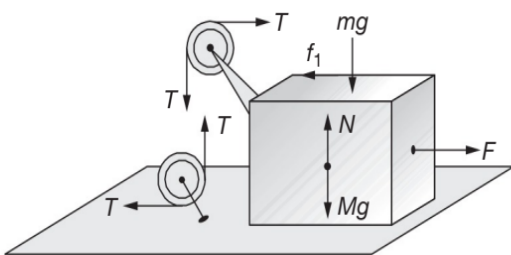

(D) None of these

20. For a particular force F it is found that $f_1 = 2f_2$.

(A) $f_1 = 15 \text{ N}$, $f_2 = 30 \text{ N}$

(B) $f_1 = 30 \text{ N}$, $f_2 = 60 \text{ N}$

(C) $f_1 = 30 \text{ N}$, $f_2 = 60 \text{ N}$

(D) $f_1 = 30 \text{ N}$, $f_2 = 15 \text{ N}$

21. The value of F such that condition $f_1 = 2f_2$ is fulfilled is

(A) 60 N (B) 30 N

(C) 45 N (D) 15 N

22. Tension in the string is

(A) 15 N (B) 16 N

(C) 17 N (D) 18 N

23. Accelerations of the masses

(A) $a_M = \frac{2}{5} \text{ ms}^{-2}$, $a_{m_1} = \frac{3}{5} \text{ ms}^{-2}$, $a_{m_2} = \frac{3}{5} \text{ ms}^{-2}$

(B) $a_M = \frac{3}{5} \text{ ms}^{-2}$, $a_{m_1} = \frac{3}{5} \text{ ms}^{-2}$, $a_{m_2} = \frac{2}{5} \text{ ms}^{-2}$

(C) $a_M = a_{m_1} = a_{m_2} = \frac{3}{5} \text{ ms}^{-2}$

(D) $a_M = a_{m_1} = a_{m_2} = 0$

Comprehension 8

A particle moves in the xy plane under the action of a force \vec{F} such that the value of its linear momentum \vec{p} at any time t is $p_x = 2\cos t$ and $p_y = 2\sin t$. Based on the above facts, answer the following questions.

24. The magnitude of the force is

(A) 1 unit (B) 2 units

(C) 3 units (D) 4 units

25. What is the angle between \vec{F} and \vec{p} ?

(A) 0° (B) 30°

(C) 45° (D) 90°

26. The magnitude of the momentum is

(A) 1 unit (B) 2 units

(C) 3 units (D) 4 units

Comprehension 9

A block of mass m slides down an inclined plane of elevation angle α . The incline is fixed end to end in an elevator of base length l . Assume that initially the particle is at the top of the incline. Based on the above facts, answer the following questions.

27. When the elevator accelerates up with acceleration a_0 , then the acceleration of the particle with respect to the incline is

(A) $g \sin \alpha$ (B) $(g + a_0) \sin \alpha$

(C) $a_0 \sin \alpha$ (D) $g \sin \alpha + a_0 \cos \alpha$

28. Consider that the elevator falls freely, in such a situation, the force exerted by the block on the elevator is

(A) $mg \sin \alpha$ (B) $mg \cos \alpha$

(C) zero (D) None of these

29. The time taken by the particle to reach the bottom of the incline, when the elevator accelerates up with acceleration a_0 is T . Then

(A) $T = \sqrt{\frac{2l}{g \sin \alpha}}$ (B) $T = \sqrt{\frac{4l}{(g + a_0) \sin(2\alpha)}}$

(C) $T = \sqrt{\frac{2l}{a_0 \sin(2\alpha)}}$ (D) $T = \sqrt{\frac{l}{(g + a_0) \sin(2\alpha)}}$

30. If the elevator moves with constant velocity, then the time taken by the block to reach the bottom of the incline is

6.180 JEE Advanced Physics: Mechanics - I

- (A) $\sqrt{\frac{2l}{g \sin(2\alpha)}}$ (B) $\sqrt{\frac{2l}{g \cos \alpha}}$
 (C) $\sqrt{\frac{2l}{g}}$ (D) $\sqrt{\frac{4l}{g \sin(2\alpha)}}$

Comprehension 10

A block of mass m slides down a smooth incline of mass M and length l , solely as a result of the force of gravity. The incline is placed on a smooth horizontal table as shown in figure. Let us denote the coordinate system relative to the table as S and the coordinate system relative to the incline as S' .

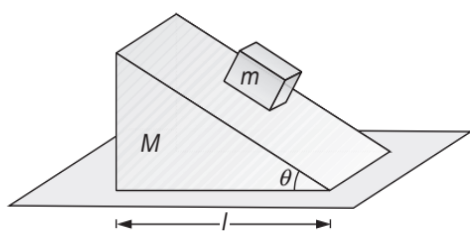

31. The acceleration of m in the S' frame is
 (A) $\frac{(M+m)g \sin \theta}{M+m \sin^2 \theta}$ (B) $\frac{(M+m)g \sin \theta}{m-M \sin^2 \theta}$
 (C) $\frac{(M-m)g \sin \theta}{M+m \sin^2 \theta}$ (D) $\frac{(M+m)g \sin \theta}{M+m \sin \theta}$
32. The acceleration of the incline in the S frame
 (A) $\left(\frac{mg \sin \theta \cos \theta}{M-m \sin^2 \theta}\right)$ (B) $\left(\frac{mg \sin \theta \cos \theta}{M+m \sin^2 \theta}\right)$
 (C) $\left(\frac{Mg \sin \theta \cos \theta}{M-m \sin^2 \theta}\right)$ (D) $\left(\frac{Mg \sin \theta \cos \theta}{M+m \sin^2 \theta}\right)$
33. The force exerted by the small m on the wedge of mass M
 (A) $mg \cos \theta$ (B) $\frac{Mmg \cos \theta}{M+m \sin^2 \theta}$
 (C) $\frac{mg}{\cos \theta}$ (D) None of these

Comprehension 11

A heavy block of mass 250 kg is being pulled up an inclined plane of angle 30° by means of a wire passing over a pulley of radius 5 cm and connected to a motor as shown in the figure. The power output of the motor is 5 kW and the block moves up with a constant velocity of 2 ms^{-1} . Based on the information provided, answer the following questions.

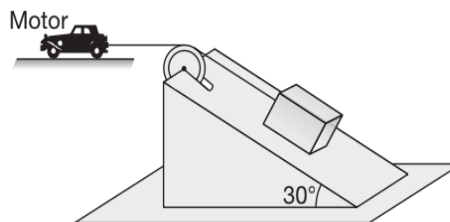

34. The coefficient of friction between the block and the inclined surface is
 (A) $\frac{1}{\sqrt{2}}$ (B) $\frac{1}{\sqrt{3}}$
 (C) $\frac{1}{2}$ (D) $\frac{1}{\sqrt{5}}$
35. Contact force between the inclined plane and heavy block
 (A) 1250 N (B) 25000 N
 (C) 5000 N (D) 2500 N
36. Tension in the string
 (A) 250 N (B) 1250 N
 (C) 2500 N (D) 5000 N
37. Frictional force acts on the block
 (A) 12.5 N (B) 125 N
 (C) 1250 N (D) 12500 N

Comprehension 12

A bead of mass m is attached to one end of a spring of natural length R and spring constant $k = \frac{(\sqrt{3}+1)mg}{R}$. The other end of the spring is fixed at point A on a smooth vertical ring of radius R as shown in figure. Based on the information provided, answer the following questions.

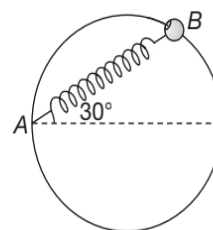

38. The normal reaction at B just after it is released to move is
 (A) $\frac{mg}{2}$ (B) $\sqrt{3}mg$
 (C) $3\sqrt{3}mg$ (D) $\frac{3\sqrt{3}mg}{2}$
39. Tangential acceleration of the bead just after it is released is

- (A) $\frac{g}{2}$ (B) $\frac{g}{4}$
 (C) $\frac{2g}{3}$ (D) $\frac{3g}{4}$

Comprehension 13

A painter of mass 100 kg is raising himself and the crate (such an arrangement is called Bosun's chair) on which he stands as shown. When he pulls the rope the force exerted by him on the crate's floor is 450 N. If the crate weighs 25 kg then, based on the information provided, answer the following questions.



40. The acceleration of the system (painter + crate) is
 (A) 22 ms^{-2} , up (B) 2 ms^{-2} , down
 (C) 2 ms^{-2} , down (D) 22 ms^{-2} , down
41. The tension in the cable supporting the cabin is
 (A) 500 N (B) 1000 N
 (C) 1250 N (D) 750 N
42. Assuming the painter to be of mass M , crate to be of mass m , then the system will be in equilibrium when the painter holds the rope with a force given by
 (A) $(m + M)g$ (B) $(M - m)g$
 (C) $\frac{1}{2}(M + m)g$ (D) $\frac{1}{2}(M - m)g$

Comprehension 14

A particle of mass m is suspended by the two strings a and b each of length l as shown. Based on this simple information, answer the following questions.

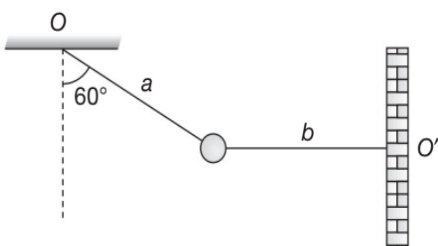

43. In equilibrium, tension in the string a is
 (A) $2mg$ (B) $\sqrt{3}mg$
 (C) mg (D) $3mg$
44. In equilibrium, tension in the string b is
 (A) $2mg$ (B) $\sqrt{3}mg$
 (C) mg (D) $3mg$
45. If the string a is now burned then the speed of the ball just before it collides with the wall is
 (A) $\sqrt{\frac{gl}{2}}$ (B) $\sqrt{2gl}$
 (C) \sqrt{gl} (D) $\frac{\sqrt{gl}}{2}$

Comprehension 15

The system shown in the figure is in equilibrium. The masses m_1 and m_2 are 2 kg and 8 kg respectively, the springs have spring constants $k_1 = 50 \text{ Nm}^{-1}$ and $k_2 = 70 \text{ Nm}^{-1}$ and the compression in second spring is 0.5 m. Assuming both the springs to have the same natural length, answer the following questions.

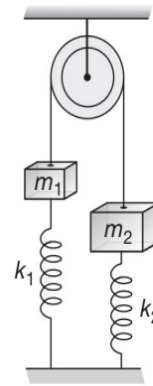

46. The extension in first spring is
 (A) 1.3 m (B) -0.5 m
 (C) 0.5 m (D) 0.9 m
47. The tension in the string is
 (A) 45 N (B) 40 N
 (C) 50 N (D) 38 N
48. The acceleration of the mass m_1 , when spring k_1 is cut, is
 (A) zero (B) 2.5 ms^{-2}
 (C) 3 ms^{-2} (D) None of these

Comprehension 16

A block of mass M is placed on a horizontal surface and it is tied through an inextensible string to a block of mass m ,

6.182 JEE Advanced Physics: Mechanics - I

as shown in figure. A block of mass m_0 is also placed on M . Based on the information provided, answer the following questions.

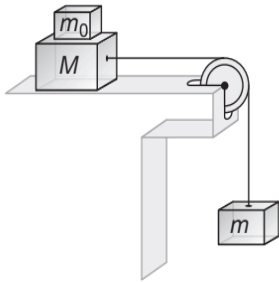

49. If there is no friction between any two surfaces in contact, then
 (A) a downward acceleration of the block m is $\frac{mg}{m+m_0+M}$
 (B) the acceleration of m_0 is zero
 (C) the tension in the string is $Mg < T < mg$
 (D) All the above
50. If a friction force exist between block M and the horizontal surface with the coefficient of friction μ , then the minimum value of μ (call it as μ_{\min}) for which the block m remains stationary is
 (A) $\frac{m}{M}$ (B) $\frac{m}{M+m_0}$
 (C) $\frac{M+m_0}{M}$ (D) $\frac{M}{M+m_0}$

51. If $\mu < \mu_{\min}$ (the minimum friction required to keep the block m stationary), then the downward acceleration of m is
 (A) $\left[\frac{m - \mu M}{m + M} \right] g$ (B) $\left[\frac{m - \mu(m_0 + M)}{m + m_0 + M} \right] g$
 (C) $\left[\frac{m - \mu(m_0 + M)}{m + M} \right] g$ (D) $\left[\frac{m - \mu M}{m + m_0 + M} \right] g$

Comprehension 17

$ABCD$ is a vertical frame of mass M . Two strings between block of mass m and frame are ideal and lies in vertical plane. The frame $ABCD$ is placed on horizontal smooth surface and a horizontal force F is applied as shown. Points P and Q are in same vertical line and two strings are of equal length.

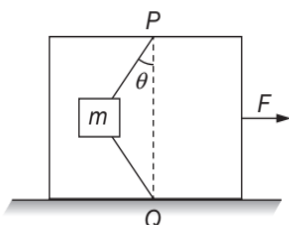

Based on the above facts, answer the following questions.

52. Minimum force F required to make both string tight is
 (A) $Mg \tan \theta$ (B) $Mg \cot \theta$
 (C) $(m + M)g \tan \theta$ (D) $(m + M)g \cot \theta$
53. If the lower string is just tight then tension in the upper string is
 (A) $\frac{mg}{\sin \theta}$ (B) $\frac{mg}{\cos \theta}$
 (C) $mg \sin \theta$ (D) $mg \cos \theta$
54. The value of force F for which the tension in upper string becomes twice than tension in lower string is
 (A) $3(m + M)g \tan \theta$ (B) $2(m + M)g \tan \theta$
 (C) $4(m + M)g \tan \theta$ (D) None of these

Comprehension 18

A block of mass $m = 2$ kg kept on a wedge of mass $M = 9$ kg and a horizontal force of 210 N is applied on the wedge as shown. All the surfaces are smooth and $g = 10 \text{ ms}^{-2}$. If initially, when the force is applied, the block m is at the bottom of wedge and if the base length of wedge is 10 m.

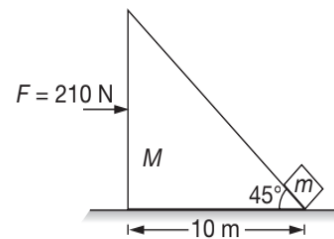

Based on the above facts, answer the following questions.

55. Acceleration of wedge when mass m is moving on it
 (A) $\frac{210}{11} \text{ ms}^{-2}$ (B) $\frac{10}{\sqrt{2}} \text{ ms}^{-2}$
 (C) 20 ms^{-2} (D) $10\sqrt{2} \text{ ms}^{-2}$
56. Speed of block m with respect to wedge when it reaches the top of wedge is
 (A) $\frac{210}{11} \text{ ms}^{-1}$ (B) $\frac{10}{\sqrt{2}} \text{ ms}^{-1}$
 (C) $10\sqrt{2} \text{ ms}^{-1}$ (D) 20 ms^{-1}
57. Distance moved by wedge when block m leaves the wedge from its top is
 (A) $10\sqrt{2} \text{ m}$ (B) $20\sqrt{2} \text{ m}$
 (C) 20 m (D) 40 m

Comprehension 19

An external force F is applied at an angle θ with the horizontal as shown on the block of mass m . The coefficient of friction between block and wall is μ .

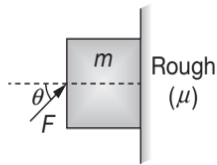

Based on the above facts, answer the following questions.

58. The minimum value of force f required to keep the block at rest is

- (A) $\frac{mg}{\mu \cos \theta}$ (B) $\frac{mg}{\sin \theta + \mu \cos \theta}$
 (C) $\frac{mg}{\sin \theta - \mu \cos \theta}$ (D) $\frac{mg}{\mu \tan \theta}$

59. The maximum value of force F up to which block remains at rest is

- (A) $\frac{mg}{\mu \cos \theta}$ (B) $\frac{mg}{\sin \theta + \mu \cos \theta}$
 (C) $\frac{mg}{\sin \theta - \mu \cos \theta}$ (D) $\frac{mg}{\mu \tan \theta}$

60. The value of force F for which friction force between block and wall is zero

- (A) mg (B) $\frac{mg}{\sin \theta}$
 (C) $\frac{mg}{\cos \theta}$ (D) $\frac{mg}{\tan \theta}$

Comprehension 20

Two blocks of masses 10 kg and 20 kg are moving together with a constant speed of 20 ms^{-1} and 10 kg block is not slipping on 20 kg when blocks are moving in region AB which is horizontal and smooth.

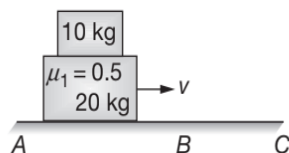

The coefficient of friction between the blocks is $\mu_1 = 0.5$. The horizontal surface BC is rough and coefficient of friction between 20 kg block and surface BC is μ_2 . Taking $g = 10 \text{ ms}^{-2}$, answer the following questions.

61. When the blocks are moving on the smooth horizontal region AB of surface, then

- (A) frictional force on 10 kg block is zero
 (B) frictional force on 10 kg block is 50 N
 (C) frictional force on 10 kg block is less than 50 N but non zero
 (D) None of these

62. When this system of blocks enters the rough horizontal surface BC then still 10 kg block is not slipping on 20 kg block, then

- (A) maximum value of μ_2 is 0.5
 (B) maximum value of μ_2 is 0.75
 (C) total kinetic friction is 100 N acting on 20 kg block for the above maximum value of μ_2
 (D) total frictional force on 20 kg block is 150 N

63. If the value of $\mu_2 = 0.2$, then in 15 seconds after the blocks have entered the rough surface

- (A) The distance travelled by them in rough surface is 75 m
 (B) The distance travelled by them in rough surface is 100 m
 (C) Total force applied by 10 kg on 20 kg block is 102 N after 15 seconds
 (D) None of these

Comprehension 21

A block is rotating in a circular track and angular speed of the block is given $\omega = at^2$, where ω is in rads^{-1} and t is in seconds, a is a constant and equal to 2 rads^{-3} . Mass of the block is 1 kg. Radius of circular track is 1 m. Based on the above facts, answer the following questions.

64. Net force acting on the block at $t = 2 \text{ s}$ is

- (A) 8 N (B) $8\sqrt{17}$ N
 (C) 32 N (D) 4 N

65. Angle between velocity vector and acceleration vector is

- (A) less than 90° (B) greater than 90°
 (C) equal to 90° (D) data is insufficient

66. Time at which rate of change of speed is equal to $\frac{1}{\sqrt{2}}$ times the net acceleration is

- (A) $\frac{1}{2}$ s (B) 1 s
 (C) 2 s (D) 4 s

Comprehension 22

All pulleys and strings shown in figure are light and there is no friction in any string and pulley.

6.184 JEE Advanced Physics: Mechanics - I

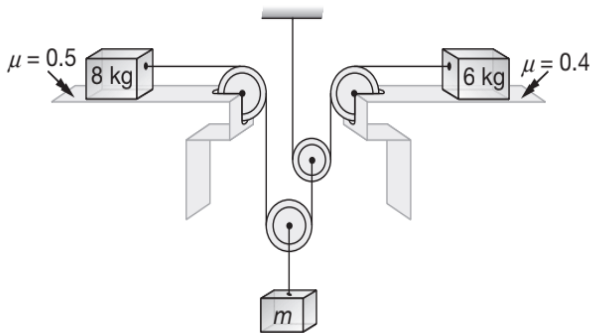

Based on the above facts, answer the following questions.

67. Maximum mass m to be hanged so that system remain in equilibrium
- (A) 8 kg (B) 9.6 kg
(C) 6.4 kg (D) 10 kg
68. Mass m to be hanged so that none of the block remains in equilibrium must satisfy
- (A) $m > 8$ kg (B) $m > 9.6$ kg
(C) $m > 10$ kg (D) $m > 12$ kg
69. Acceleration of hanging block if mass of hanging block is 9 kg
- (A) $\frac{9}{31} \text{ ms}^{-2}$ (B) $\frac{10}{31} \text{ ms}^{-2}$
(C) $\frac{10}{41} \text{ ms}^{-2}$ (D) $\frac{11}{32} \text{ ms}^{-2}$

Comprehension 23

In the situation shown below, a block of mass m is kept over wedge of mass M . Spring constant of spring shown in figure is k . All surfaces are frictionless.

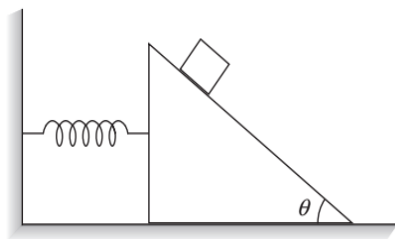

Based on the above facts, answer the following questions.

70. Compression in spring is equal to
- (A) $\frac{mg}{k}$ (B) $\frac{mg \cos \theta}{k}$
(C) $\frac{mg \sin 2\theta}{2k}$ (D) $\frac{mg \cos^2 \theta}{2k}$

71. Force on ground due to wedge is
- (A) Mg (B) $(M + m)g$
(C) $(m \cos \theta + M)g$ (D) $(m \cos^2 \theta + M)g$
72. Net force on block is equal to
- (A) $mg \sin \theta$ (B) $mg(\cos \theta + 1)$
(C) $mg \cos \theta$ (D) mg

Comprehension 24

Two blocks of masses 25 kg and 5 kg are placed on horizontal table as shown in the figure. A massless string passes over a frictionless pulley whose one end is connected to 25 kg block and other end is connected to block M . The coefficient of friction between two blocks is $\mu = 0.3$ and between 5 kg block and ground is zero. The system is released from rest.

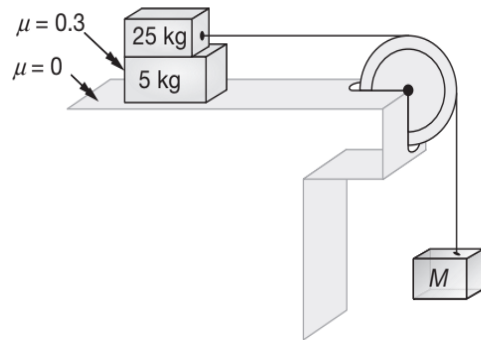

Based on the above facts, answer the following questions. (Take $g = 10 \text{ ms}^{-2}$)

73. If $M = 45$ kg force of friction between the blocks will be
- (A) 80 N (B) 60 N
(C) 30 N (D) 75 N
74. Value of M for which there is slipping between the blocks is
- (A) > 90 kg (B) $M > 0$
(C) < 90 kg (D) None of these
75. If $M = 45$ kg, acceleration of 5 kg block will be
- (A) 6 ms^{-2} (B) 5 ms^{-2}
(C) 8 ms^{-2} (D) 10 ms^{-2}

Comprehension 25

A block of mass m revolving in a circular path of radius r with a non-uniform speed of particle. Speed of particle

is given by $v = kt$, where k is constant. Time starts from $t = 0$ s. Based on the above facts, answer the following questions.

76. At $t = t_1$, magnitude of tangential acceleration is equal to magnitude of centripetal acceleration. Then t_1 is equal to

- (A) $\frac{r}{k}$ (B) rk
 (C) $\sqrt{\frac{r}{k}}$ (D) $\sqrt{\frac{k}{r}}$

77. Magnitude of net force on the particle at $t = t_1$ is

- (A) $2mk$ (B) $\sqrt{2}mk$
 (C) mk (D) $\frac{mk}{2}$

78. The angle between net acceleration vector and radius vector at $t = \frac{2}{\sqrt{3}}t_1$ is

- (A) 53° (B) 37°
 (C) 127° (D) 137°

Comprehension 26

A man of mass 50 kg is standing on a platform of mass 30 kg kept on a horizontal surface. Mass of block is 160 kg. Distance between block and pulley P is 6 m. There is no friction between block and platform. The man pulls the string with constant force 40 N.

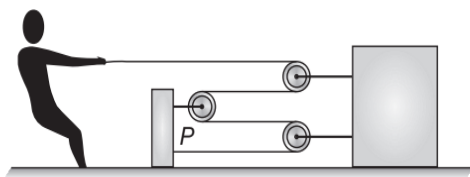

Based on the above facts, answer the following questions.

79. Assuming no friction between platform and surface, time taken by block to reach pulley is

- (A) $2\sqrt{3}$ s (B) 2 s
 (C) $3\sqrt{2}$ s (D) 3 s

80. Length of string pulled by man in 1 s is

- (A) 2 m (B) 6 m
 (C) 8 m (D) 12 m

81. The minimum coefficient between platform and the surface so that it doesn't slip on the surface

- (A) 0.05 (B) 0.1
 (C) 0.53 (D) None of these

Comprehension 27

It is observed that sometimes the frictional force opposing the motion of a body is not constant but increases with speed of the body. One of the familiar example is the air resistance on a freely falling body. For small speeds this resisting force is approximately proportional to the speed. The equations of motion are not directly applied in such cases if variable force. Based on the above facts, answer the following questions.

82. The variation of the position of a body falling freely through air can be best represented graphically by (consider $y = 0$ at the highest point)

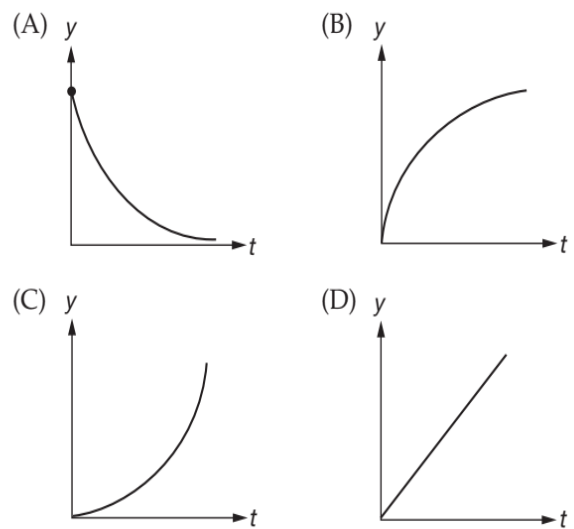

83. A 5 kg mass freely falling experiences a retarding force of $5v$ where v is the speed in ms^{-1} has

- (A) 5 (B) 10
 (C) 15 (D) 20

84. The variation of velocity with time is best represented by

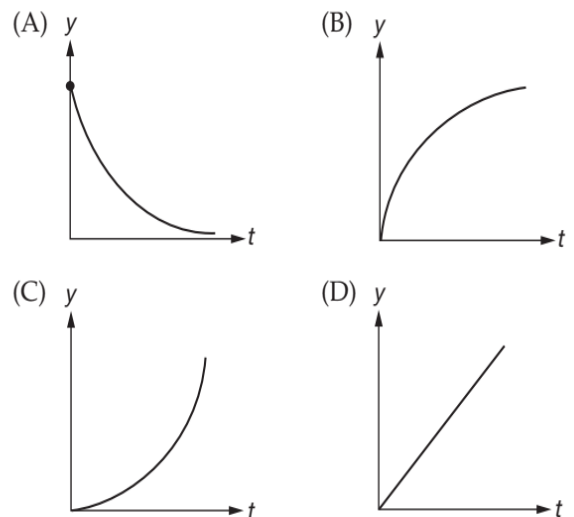

Comprehension 28

As shown two block of mass $m_1 = 2 \text{ kg}$ and $m_2 = 4 \text{ kg}$ are connected by an ideal spring of force constant $k = 1000 \text{ Nm}^{-1}$ and the system is kept on a smooth inclined plane inclined at $\theta = 30^\circ$ with horizontal. A third block of mass $m_3 = 1 \text{ kg}$ is attached to m_2 by an ideal string. A force $F = 15 \text{ N}$ is applied on m_1 and the system is released from rest. Assume that the spring was initially unstretched. ($g = 10 \text{ ms}^{-2}$).

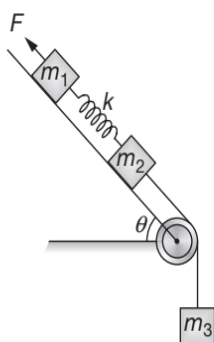

Based on the above facts, answer the following questions.

85. The common acceleration of blocks m_1, m_2 and m_3 is

- (A) $\frac{25}{7} \text{ ms}^{-2}$ (B) $\frac{35}{7} \text{ ms}^{-2}$
 (C) $\frac{15}{7} \text{ ms}^{-2}$ (D) $\frac{7}{25} \text{ ms}^{-2}$

86. Maximum elongation in spring is

- (A) 1 cm (B) 2.4 cm
 (C) 3.6 cm (D) 4.8 cm

87. Acceleration of m_3 when spring has maximum elongation is (approx.)

- (A) 1.2 ms^{-2} (B) 2 ms^{-2}
 (C) 1 ms^{-2} (D) 1.5 ms^{-2}

MATRIX MATCH/COLUMN MATCH TYPE QUESTIONS

Each question in this section contains statements given in two columns, which have to be matched. The statements in COLUMN-I are labelled A, B, C and D, while the statements in COLUMN-II are labelled p, q, r, s (and t). Any given statement in COLUMN-I can have correct matching with ONE OR MORE statement(s) in COLUMN-II. The appropriate bubbles corresponding to the answers to these questions have to be darkened as illustrated in the following examples:

If the correct matches are $A \rightarrow p, s$ and t ; $B \rightarrow q$ and r ; $C \rightarrow p$ and q ; and $D \rightarrow s$ and t ; then the correct darkening of bubbles will look like the following:

	p	q	r	s	t
A	<input checked="" type="checkbox"/>	<input type="checkbox"/>	<input type="checkbox"/>	<input checked="" type="checkbox"/>	<input checked="" type="checkbox"/>
B	<input type="checkbox"/>	<input checked="" type="checkbox"/>	<input checked="" type="checkbox"/>	<input type="checkbox"/>	<input type="checkbox"/>
C	<input checked="" type="checkbox"/>	<input checked="" type="checkbox"/>	<input type="checkbox"/>	<input type="checkbox"/>	<input type="checkbox"/>
D	<input type="checkbox"/>	<input type="checkbox"/>	<input type="checkbox"/>	<input checked="" type="checkbox"/>	<input checked="" type="checkbox"/>

1. In the diagram shown in figure a light string is attached to the mass and is pulled by a constant force $F = 20\sqrt{2} \text{ N}$ which makes an angle of 45° with the horizontal. Taking $g = 10 \text{ ms}^{-2}$, match the quantities in COLUMN-I with their respective match(es) in COLUMN-II.

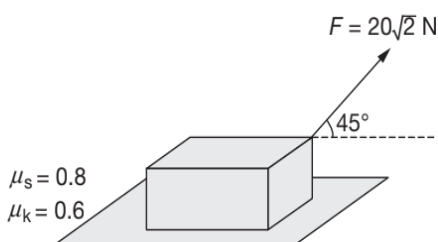

COLUMN-I	COLUMN-II
(A) Normal reaction, in newton.	(p) $20\sqrt{2}$
(B) Force of friction, in newton.	(q) 20
(C) Acceleration of block, in cms^{-2} .	(r) 12
(D) Tension in the string, in newton.	(s) 200

2. In the diagram shown in figure, all pulleys are smooth and massless and strings are light. Match the following. (Take $g = 10 \text{ ms}^{-2}$)

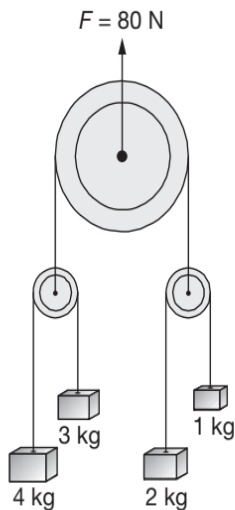

COLUMN-I	COLUMN-II
(A) Acceleration of 1 kg block	(p) up
(B) Acceleration of 2 kg block	(q) 5 ms^{-2}
(C) Acceleration of 3 kg block	(r) down
(D) Acceleration of 4 kg block	(s) $\frac{10}{3} \text{ ms}^{-2}$
	(t) Stationary
	(u) 10 ms^{-2}

3. In the diagram shown in figure, match the following ($g = 10 \text{ ms}^{-2}$).

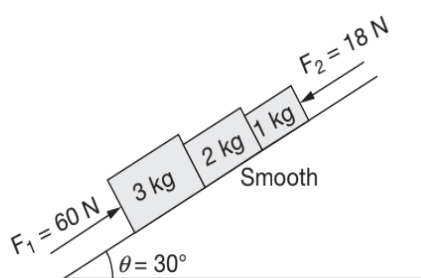

COLUMN-I	COLUMN-II
(A) Acceleration of 1 kg block, in ms^{-2} .	(p) 29
(B) Net force on 3 kg block, in N.	(q) 39
(C) Force exerted on 2 kg by 1 kg, in N.	(r) 2
(D) Force exerted on 3 kg by 2 kg, in N.	(s) 6
	(t) 25

4. Velocity of five particles A, B, C, D and E varies with time t as, $\vec{v}_A = (8\hat{i} + 6\hat{j}) \text{ ms}^{-1}$, $\vec{v}_B = (4\hat{i} + 3\hat{j}) \text{ ms}^{-1}$, $\vec{v}_C = (6\hat{i} - 4\hat{j})$, $\vec{v}_D = (-3\hat{i} + 5\hat{j}) \text{ ms}^{-1}$ and $\vec{v}_E = (2\hat{i} + 5\hat{j}) \text{ ms}^{-1}$. Match the pseudo force as observed and specified in COLUMN-I to the respective directions given in COLUMN-II.

COLUMN-I	COLUMN-II
(A) On A as observed by B.	(p) Along positive x -direction
(B) On B as observed by C.	(q) Along negative x -direction
(C) On C as observed by D.	(r) Along positive y -direction
(D) On D as observed by E.	(s) Along negative y -direction
(E) On E as observed by A.	(t) Zero

5. In the arrangement shown in figure the coefficient of friction between 1 kg and 2 kg block is $\mu = 0.4$, and that between 2 kg block and group is 0.6. Match the following.

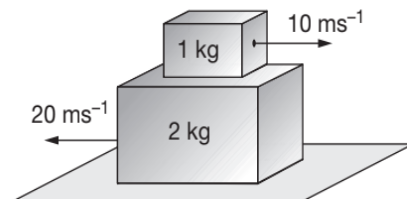

COLUMN-I	COLUMN-II
(A) 11	(p) absolute acceleration of 1 kg block, in ms^{-2}
(B) 22	(q) absolute acceleration of 2 kg block, in ms^{-2}
(C) 4	(r) relative acceleration between the two, in ms^{-2}
(D) 15	(s) net force on 2 kg block, in N
	(t) net force on 1 kg block, in N

6. One or more of the entries of COLUMN-II may be the cause of linear motions described in COLUMN-I. Give the appropriate match(es) for the entries of COLUMN-I from COLUMN-II.

COLUMN-I	COLUMN-II
(A) Object moving along $+x$ axis with constant velocity	(p) Net force on the object must act along $+x$ axis
(B) Object moving along $+x$ axis under varying acceleration	(q) At least one force must act along $+x$ axis
(C) Object moving along $+x$ axis under constant acceleration	(r) No net force may act on the object
(D) Object moving along $+x$ axis	(s) No force may be acting along $+x$ axis

7. Two blocks having masses m_1 and m_2 are placed on smooth horizontal surfaces (as shown) for the different horizontal combination of the respective forces F_1 and F_2 applied on m_1 and m_2 . Further it is given that $m_1 F_2 > m_2 F_1$, a_1 and a_2 are the accelerations of m_1 and m_2 if F_1 and F_2 would have acted on them separately.

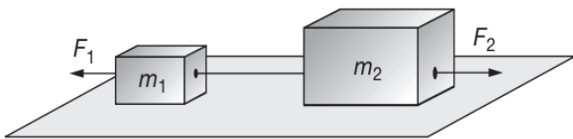

CASE-I

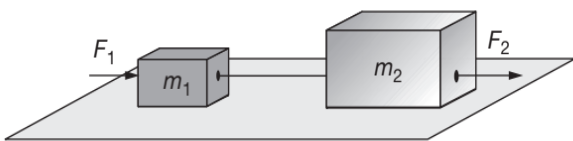

CASE-II

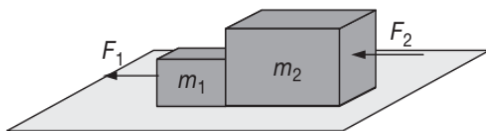

CASE-III

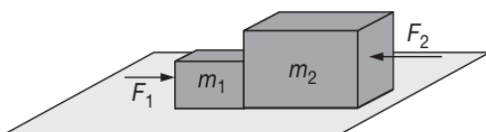

CASE-IV

If T_1 , T_2 , N_1 and N_2 be the respective tensions and the normal reactions in Case-I, II, III and IV, then match T_1 , T_2 , N_1 and N_2 from COLUMN-I to their values in COLUMN-II.

COLUMN-I	COLUMN-II
(A) T_1	(p) $\frac{m_1 m_2}{m_1 + m_2} \left(\frac{F_2}{m_2} - \frac{F_1}{m_1} \right)$
(B) N_1	(q) $\frac{m_1 m_2}{m_1 + m_2} (a_2 + a_1)$
(C) T_2	(r) $\frac{m_1 m_2}{m_1 + m_2} \left(\frac{F_1}{m_1} + \frac{F_2}{m_2} \right)$
(D) N_2	(s) $\frac{m_1 m_2}{m_1 + m_2} (a_2 - a_1)$

8. A block of mass $m = 5$ kg is moving right with velocity $v_0 = 33$ ms $^{-1}$ on a rough surface. A force $F = 20\sqrt{2}$ is applied as shown ($g = 10$ ms $^{-2}$)

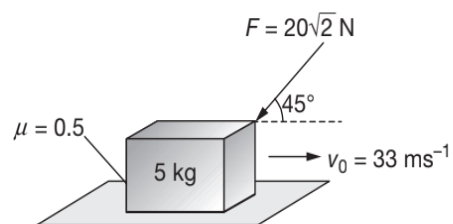

COLUMN-I	COLUMN-II
(A) at $t = 2.5$ s, friction force is	(p) zero
(B) at $t = 4.5$ s, friction force is	(q) 55 N
(C) at $t = 2.5$ s, net retardating force is	(r) 35 N
(D) at $t = 4.5$ s, net force on block is	(s) 15 N
	(t) 20 N

9. In the arrangement shown, a block A of mass $m_A = 1$ kg is sliding on a block B of mass $m_B = 4$ kg. Friction is absent between all surfaces in contact. Based on this information and $g = 10$ ms $^{-2}$, match the items of COLUMN-I with their respective values in COLUMN-II.

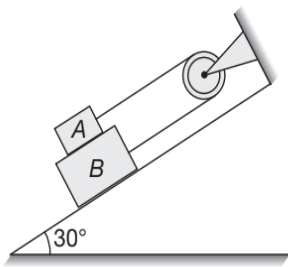

COLUMN-I	COLUMN-II
(A) Acceleration of A , in ms^{-2}	(p) $5\sqrt{3}$
(B) Thrust on the pulley, in N	(q) $25\sqrt{3}$
(C) Force exerted by A on B , in N	(r) 3
(D) Force exerted by B on incline, in N	(s) 8
	(t) 16

10. Configuration of L shaped block B of mass 6 kg and two other blocks are shown. System is set free to move. At any moment, match the following parameters. ($g = 10 \text{ ms}^{-2}$).

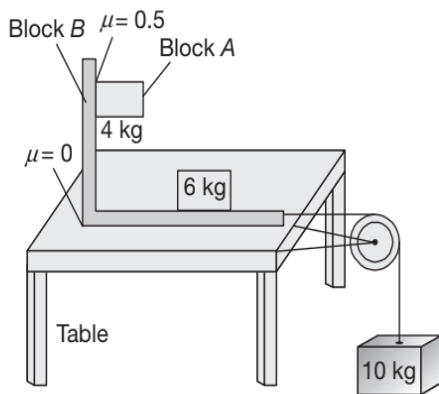

COLUMN-I	COLUMN-II
(A) Friction force between block A and B	(p) 50 N
(B) Tension in the string	(q) 70 N
(C) Normal reaction on block A by block B	(r) 60 N
(D) Normal reaction on block B by table	(s) 10 N
	(t) 20 N

11. A block A of mass 10 kg lies on a block B of mass 25 kg resting on a smooth horizontal surface. The coefficient of static friction between A and B is $\mu = 0.5$. A force F is applied on the block A , as shown.

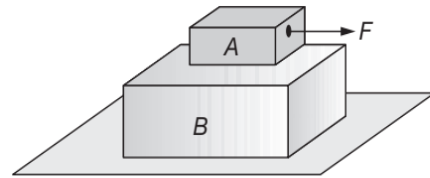

COLUMN-I	COLUMN-II
(A) Force of friction on B due to A , in N.	(p) 1
(B) Acceleration of A (in ms^{-2}) for $F = 35 \text{ N}$.	(q) 20
(C) Acceleration of A (in ms^{-2}), for $F = 250 \text{ N}$.	(r) towards left
(D) Acceleration of B (in ms^{-2}), for $F = 250 \text{ N}$.	(s) 2
	(t) 50
	(u) towards right

12. If the net force acting on a system is represented by \vec{F} and its momentum is \vec{p} , then match the quantities in COLUMN-I with the quantities in COLUMN-II.

COLUMN-I	COLUMN-II
(A) If \vec{F} is constant	(p) \vec{p} may change its direction
(B) If \vec{F} is changing in magnitude	(q) \vec{p} must change its magnitude
(C) If \vec{F} is changing in direction	(r) \vec{p} may not change its direction
(D) If \vec{F} is zero	(s) \vec{p} must not change its direction

13. $ABCD$ is a horizontal surface on which a block of mass $m = 20 \text{ kg}$ is placed and coefficient of friction between this body and surface is $\mu = 0.5$ as shown. y -axis is vertical axis and x - z plane is horizontal. The surface starts moving with an acceleration which depends on time as $\vec{a} = (3t\hat{i} + 10\hat{j} + 4t\hat{k}) \text{ ms}^{-2}$.

6.190 JEE Advanced Physics: Mechanics - I

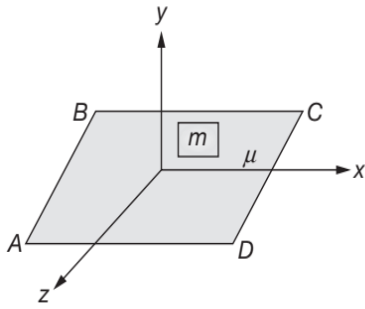

Assuming that at $t = 0$, the block is at rest with respect to the surface. If, t is time when block starts slipping, a is the acceleration of surface when block starts slipping, f_1 is limiting friction when block starts slipping, F is total force applied by surface on block at $t = 1$ s, then match the quantities in COLUMN-I with their respective values in COLUMN-II.

COLUMN-I	COLUMN-II
(A) t	(p) 200
(B) a	(q) $100\sqrt{17}$
(C) f_1	(r) $10\sqrt{2}$
(D) F	(s) 2

14. Match the force or set of forces in the left hand column to a characteristic of force or set of forces in the right-hand column.

COLUMN-I (Force)	COLUMN-II (Characteristic)
(A) Electric (Electrostatic)	(p) Proportional to $\frac{1}{(\text{distance})^2}$
(B) Gravity	(q) Always attracts
(C) Both Electric and Gravity	(r) Always repels
(D) Neither electric nor gravity	(s) Attracts or repels
	(t) Central force

15. In the arrangement shown pulley is ideal and string is massless. 5 kg block is moving on the horizontal which is smooth. When θ is 37° acceleration of 5 kg and 10 kg blocks are a_1 and a_2 . Tension in string

connecting blocks is T and the total force applied by this string on pulley is F . Taking, $g = 10 \text{ ms}^{-2}$, match the quantities in COLUMN-I to their respective values (in SI units) in COLUMN-II.

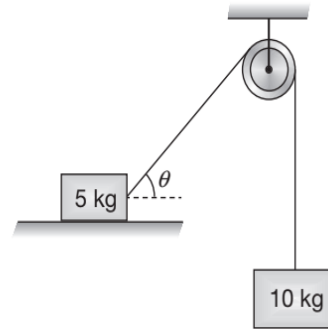

COLUMN-I	COLUMN-II
(A) a_1	(p) 5.6
(B) a_2	(q) 43.75
(C) T	(r) 7
(D) F	(s) 78.26

16. A metal sphere is hung by a string fixed to a wall. The forces acting on the sphere are shown. Match the following:

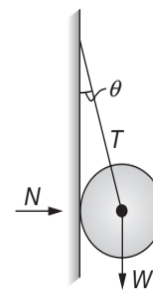

COLUMN-I	COLUMN-II
(A) $\vec{T} =$	(p) $(-\vec{W} - \vec{N})$
(B) $T^2 =$	(q) $W \tan \theta$
(C) $N =$	(r) $(N^2 + W^2)$
(D) $\vec{N} + \vec{T} + \vec{W} =$	(s) zero
	(t) None of these

17. A block A of mass 5 kg is placed on another block B of mass 10 kg placed on a horizontal rough surface. Horizontal forces F_1 and F_2 act on blocks A and B , respectively as shown in figure. Coefficient of friction between two blocks is 0.8 while between block B and horizontal surface is 0.2. Let f_1 denote friction force acting on block B due to A and f_2 denote friction force on horizontal surface. Then match the following.

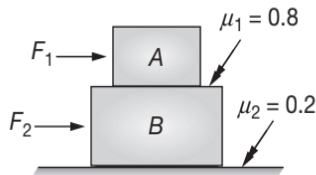

COLUMN-I	COLUMN-II
(A) If $F_1 = 35 \text{ N}$, $F_2 = 0$ then f_1	(p) Kinetic
(B) If $F_1 = 50 \text{ N}$, $F_2 = 0$ then f_2	(q) Static
(C) If $F_1 = 0$, $F_2 = 30$ then f_1	(r) zero
(D) If $F_1 = 10 \text{ N}$, $F_2 = 50 \text{ N}$ then f_1	(s) Towards right

INTEGER/NUMERICAL ANSWER TYPE QUESTIONS

In this section, the answer to each question is a numerical value obtained after doing series of calculations based on the data given in the question(s).

1. One end of a 0.5 m long string is fixed to a point A and the other end is fastened to a small object of weight 8 N. The object is pulled aside by a horizontal force F , until it is 0.3 m from the vertical through A . Find the magnitudes of the tension T in the string and the force F . Give your answer in newton.

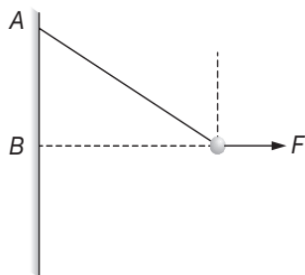

2. Block B in figure weighs 692 N. The coefficient of static friction between block and table is 0.25. Assuming that the cord between B and the knot is horizontal, find the maximum weight of block A , in kgwt for which the system will be stationary. Take $\sqrt{3} = (1.73)^2$ and $g = 10 \text{ ms}^{-2}$.

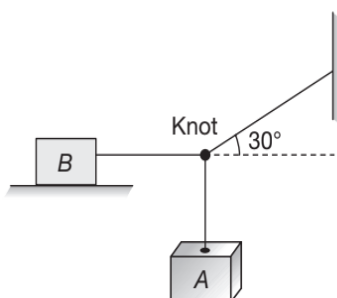

3. In the arrangement shown, determine the tensions, in newton, T_1 , T_2 and T_3 in the strings. Take $g = 10 \text{ ms}^{-2}$ and $\sqrt{3} = 1.7$.

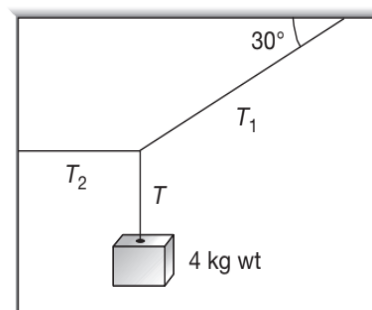

4. Find the mass m of the counterweight needed to balance the 1500 kg car on the incline shown in figure. Assume all pulleys are frictionless and massless.

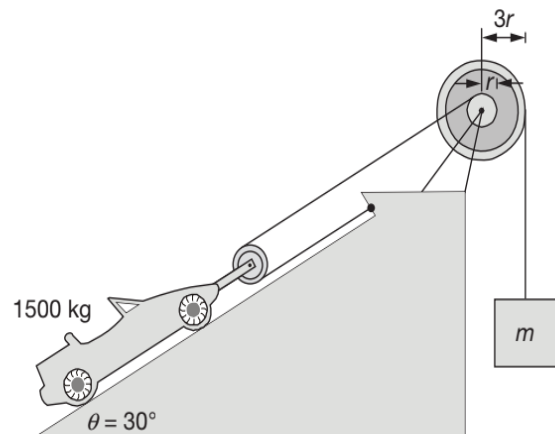

6.192 JEE Advanced Physics: Mechanics - I

5. Under the action of force P , the constant acceleration of block B is 6 ftsec^{-2} up the incline. For the instant when the velocity of B is 3 ftsec^{-1} up the incline, determine the velocity of B relative to A , the acceleration of B relative to A in ftsec^{-2} and the absolute velocity of point C in ftsec^{-1} of the cable.

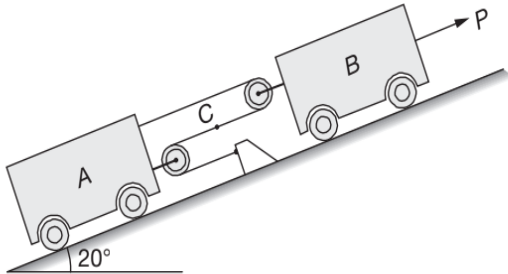

6. Determine the vertical rise h , in mm, of the load W during 5 s, if the hoisting drum wraps cable around it at the constant rate of 320 mms^{-1} .

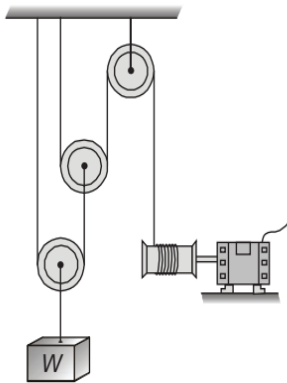

7. In the arrangement shown, find the speed, in cms^{-1} , of B , if A is moving downwards with a speed of $v_A = 4 \text{ ms}^{-1}$ at the instant shown.

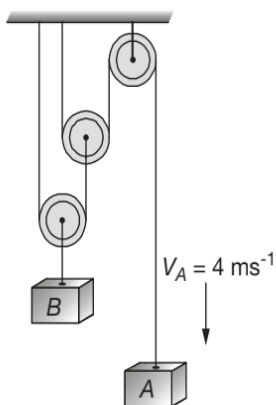

8. In the arrangement shown, find the speed of cylinder A , if the rope is drawn towards the motor M at a constant rate of 9 ms^{-1} .

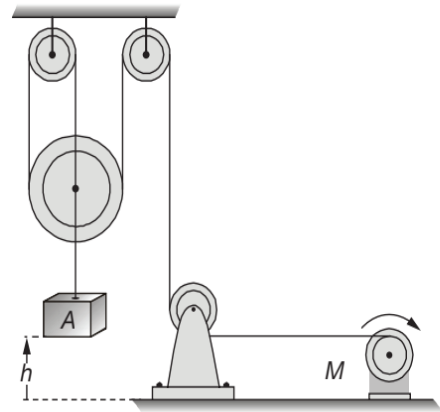

9. In the arrangement shown in figure. The strings are light and inextensible. The surface over which blocks are placed is smooth. Find:

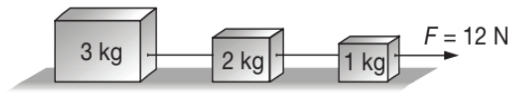

- (a) the acceleration of each block, in ms^{-2}
 (b) the tension in each string, in newton.

10. Consider the situation shown in figure the block B moves on a frictionless surface, while the coefficient of friction between A and the surface on which it moves is 0.2. Find the acceleration, in ms^{-2} , with which the masses move and also the tension, T_1 and T_2 in the left and the right string, in newton. Take $g = 10 \text{ ms}^{-2}$.

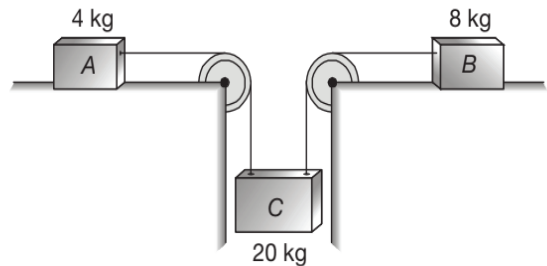

11. A block of mass 200 kg is set into motion on a frictionless horizontal surface with the help of frictionless pulley and a rope system as shown in figure. What horizontal force F , in newton, should be applied to produce in the block an acceleration of 1 ms^{-2} ?

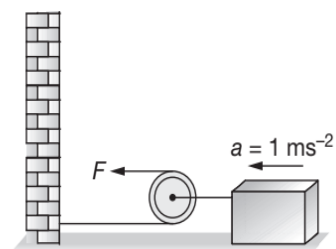

12. Determine the normal force, in newton, the 10 kg crate *A* exerts on the smooth block *B* if the block is given an acceleration of $a = 2 \text{ ms}^{-2}$ down the fixed incline. Also, find the acceleration of the crate, in ms^{-2} , for $\theta = 30^\circ$. Take $g = 10 \text{ ms}^{-2}$.

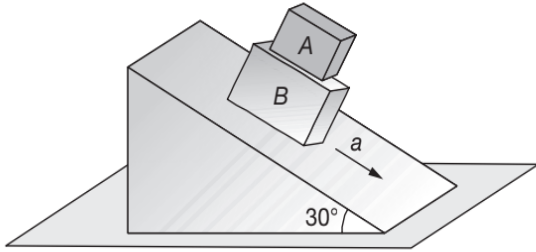

13. The coefficient of friction between the road and the tyre of a vehicle is $\frac{4}{3}$. Find the maximum incline of the road (in degree to the nearest two digit integer) so that once hard brakes are applied and the wheel starts skidding, the vehicle going down at a speed of 10 ms^{-1} is stopped within 5 m ($g = 10 \text{ ms}^{-2}$).

14. Figure shows a man of mass $M = 65 \text{ kg}$ standing stationary with respect to a horizontal conveyor belt accelerating at 1 ms^{-2} . Calculate the net force, in newton, on the man. If the coefficient of static friction between the man's shoes and the belt is 0.2, upto what acceleration, in cms^{-2} , of the belt can the man continue to be stationary relative to the belt? Take $g = 10 \text{ ms}^{-2}$.

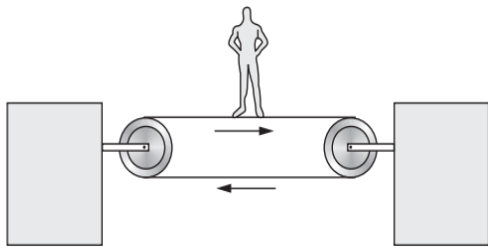

15. An initially stationary box full of sand is to be pulled across a floor by means of a cable in which the tension should not exceed 1200 N. The coefficient of friction between the box and the floor is $\frac{1}{2\sqrt{2}}$.
- What should be the angle, in degree, between the cable and the horizontal in order to pull the greatest possible amount of sand?
 - What is the combined weight of the sand and box, in newton, in that situation?

Take $\sin(10^\circ)\cos(10^\circ) = \frac{1}{6}$.

16. A 30 kg mass is initially at rest on the floor of a truck. The coefficient of static friction between the mass and the floor of truck is 0.3 and coefficient of kinetic friction is 0.2. Initially the truck is travelling due east at constant speed. Find the magnitude and direction of the friction force, in newton, acting on the mass if
- the truck accelerates at 1.8 ms^{-2} eastward.
 - the truck accelerates at 3.8 ms^{-2} westward.

17. The 4 kg disk *D* is attached to the end of a cord as shown in figure. The other end of the cord is tied at the centre of a platform. If the platform is rotating rapidly and the disk is placed on it and released from rest as shown, determine the time, in seconds, it takes for the disk to reach a speed great enough to break the cord. The maximum tension the cord can sustain is 100 N and the coefficient of kinetic friction between the disk and the platform is $\mu_k = 0.1$. Take $g = 10 \text{ ms}^{-2}$.

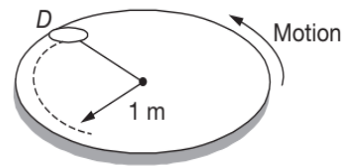

18. Coefficient of kinetic friction between 3 kg and 2 kg block is 0.3. The horizontal table surface is smooth. Find the acceleration of block of mass 10 kg. (in ms^{-2})

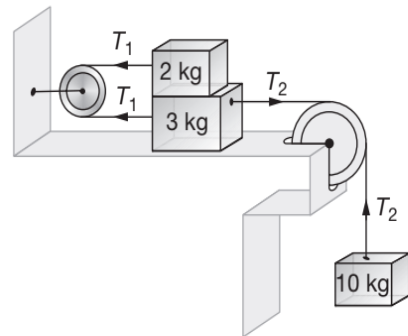

19. A 1500 kg car enters a section of curved road in the horizontal plane and slows down at a uniform rate from a speed of 100 kmph at *A* to a speed of 50 kmph as it passes *C*. The radius of curvature of the road at *A* is 400 m and at *C* is 80 m. The total horizontal force exerted by the road on tyres at position *C* is _____ N.

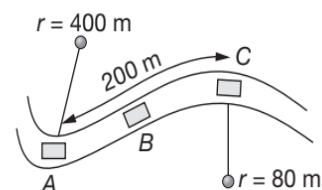

6.194 JEE Advanced Physics: Mechanics - I

20. What is the minimum radius of a circle along which a cyclist can ride with a velocity 18 kmhr^{-1} if the coefficient of friction between the tyres and the road is $\mu = 0.5$ (take $g = 10 \text{ ms}^{-2}$)
21. Three blocks of identical masses are placed at rest on a smooth inclined plane with force acting on block A parallel to the inclined plane. Find the contact force between block B and C.

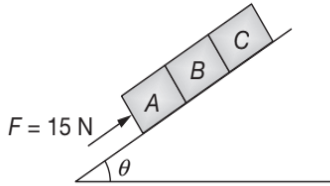

22. Two blocks 1 and 2 of mass 2 kg and 4 kg are kept over a frictionless inclined surface (angle of inclination = 30°). Coefficient of friction between two blocks is $\mu = 0.2$. Calculate the frictional force on block 1 due to 2 (in newton).

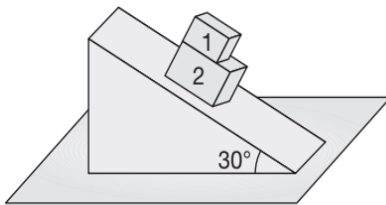

23. Two blocks of mass 2 kg and 4 kg are connected through a massless inextensible string. Coefficient of friction between 2 kg block and ground is 0.4 and between 4 kg block and ground is 0.6. Two forces $F_1 = 10 \text{ N}$ and $F_2 = 20 \text{ N}$ are applied on the block as shown in figure. Calculate the friction force (in N) acting on 4 kg block.

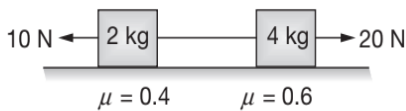

24. A light string fixed at one end to a clamp on ground passes over a fixed pulley and hangs at the other side. It makes an angle of 30° with the ground. A monkey of mass 5 kg climbs up the rope. The clamp can tolerate a vertical force of 40 N only. Find the maximum acceleration in upward direction with which the monkey can climb safely is (Neglect friction and take $g = 10 \text{ ms}^{-2}$)
25. A car begins to move at time $t = 0$ and then accelerates along a straight track with a velocity given by

$V(t) = 2t^2 \text{ ms}^{-1}$ for $0 \leq t \leq 2$, where t is time in second. After the end of acceleration, the car continues to move at a constant speed. A small block initially at rest on the floor of the car begins to slip at $t = 1 \text{ s}$ and stops slipping at $t = 3 \text{ s}$. The coefficient of static and kinetic friction between the block and the floor are μ_s and μ_k respectively. Find the value of $\frac{3\mu_s}{\mu_k}$.

26. A 40 kg wooden crate is being pushed across a wooden floor with a force of 160 N. If $\mu_k = 0.3$, find the acceleration of the crate. ($g = 10 \text{ ms}^{-2}$)
27. A block of mass 0.2 kg is kept on wedge of mass 0.6 kg which is kept on rough table. Assuming wedge to be stationary, and the block to be slipping down with constant speed 2 ms^{-1} , calculate the normal force on the wedge due to table.

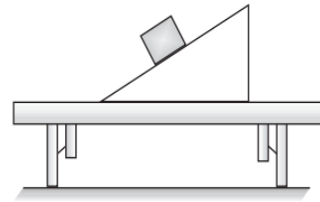

28. Pulleys are ideal and string are massless. The masses of blocks are $m_1 = 4 \text{ kg}$ and $m_2 = 1 \text{ kg}$ as shown. If all surfaces are smooth then the acceleration of m_2 in ms^{-2} is ($g = 10 \text{ ms}^{-2}$)

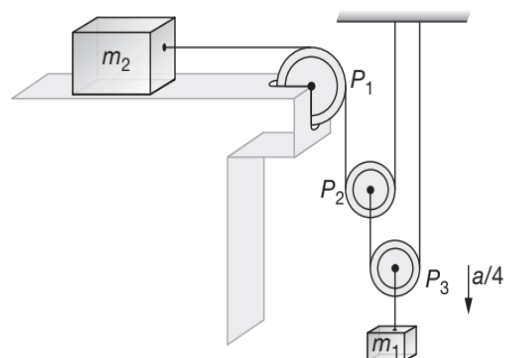

29. A block of mass 5 kg is placed on bus moving with acceleration 2 ms^{-2} . The pseudo force acting on block as seen by a man on ground is _____.
30. In the given arrangement, strings and pulleys are light and all surface are frictionless. Assuming at $t = 0$, system is released from rest, find the speed of block A in decameter per second at $t = 2 \text{ sec}$.

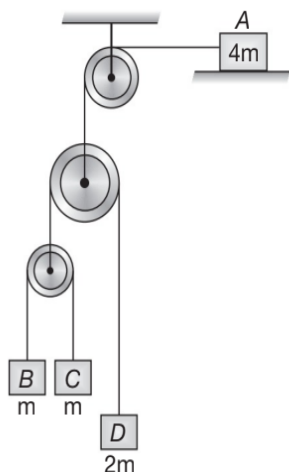

31. In the arrangement shown in figure, the end A of light inextensible string is pulled with constant velocity $v = 6 \text{ ms}^{-1}$. The velocity of block B is (in ms^{-1})

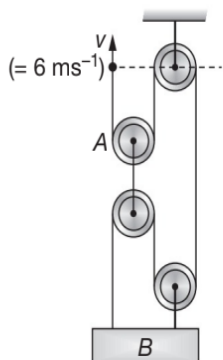

32. Figure shows a string passing through two fixed pulley P_1 and P_3 and a pulley P_2 free to move vertically. One end of string is attached with ring A . Calculate the velocity of pulley P_2 at the instant shown in ms^{-1} .

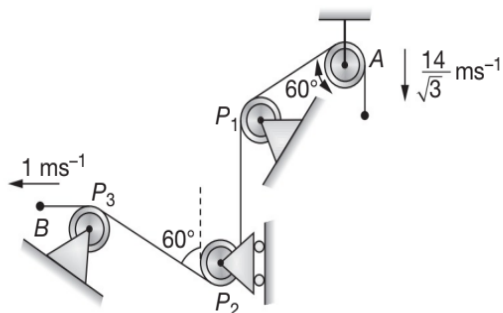

33. Find the tension in string 1. All the surfaces are frictionless. Strings are light and frictionless. (Take $g = 10 \text{ ms}^{-2}$).

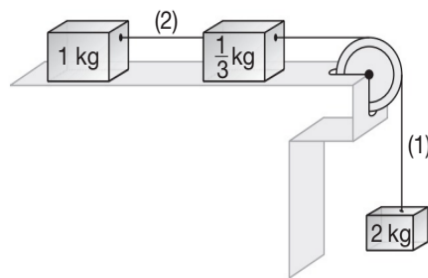

34. A block of mass 1 kg is just fit in a groove in a platform kept horizontally. The groove is along $+ve$ x -axis. The platform is given an acceleration $\vec{a} = 2\hat{i} + 3\hat{j} \text{ ms}^{-2}$. If block is not slipping on platform, then find the friction force acting on block (in newton).

35. Calculate the magnitude of the force exerted by A on B .

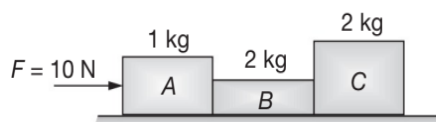

All surfaces are frictionless.

36. Two blocks 1 and 2 of mass 2 kg and 4 kg are kept connected as shown in figure. All pulley and string are massless and surfaces are frictionless. Calculate the acceleration of block 1 at the instant shown.

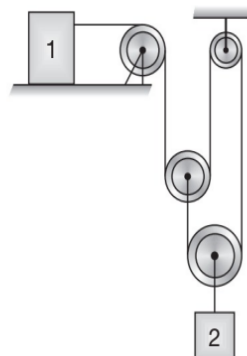

37. Two blocks A and B of equal mass m are connected through a massless string and arranged as shown in figure. Friction is absent everywhere. When the system is released from rest, then calculate the tension in string. Where m is 2 kg . ($g = 10 \text{ ms}^{-2}$)

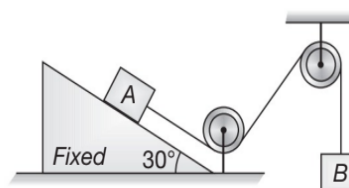

6.196 JEE Advanced Physics: Mechanics - I

38. Assuming all the surfaces to be frictionless, find the acceleration of the block C in ms^{-2} shown in figure.

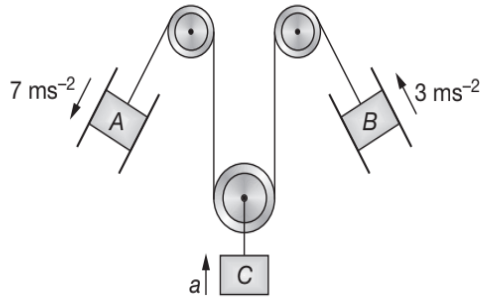

39. A block of mass 2 kg is placed on rough horizontal surface (coefficient of friction = 0.2) and is pulled by horizontal force $F = (2t)$ N where t is time in sec. Find the velocity of block at $t = 4$ seconds.

40. In the arrangement shown in figure, the mass of the rod $M = 2$ kg exceeds the mass $m = 0.5$ kg of the ball. The mass has an opening permitting it to slide along the thread with some friction. The mass of the pulley and the friction in its axle are negligible. At the initial moment ball was located opposite to the lower end of the rod. When set free, both bodies began moving with constant accelerations. Find the friction force between the ball and the thread if $t = 2$ second after the beginning of motion of the ball, the ball got opposite the

upper end of the rod. The rod length equals $l = 0.3$ m. (in 10^{-1}).

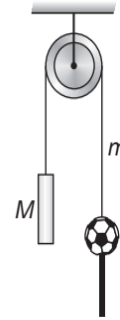

41. Three blocks A, B and C of mass m each are arranged in pulley mass system as shown. Coefficient of friction between block A and horizontal surface is equal to 0.5 and a force P acts on A in the direction shown. Calculate $\frac{P}{mg}$ so that block 'C' doesn't move.

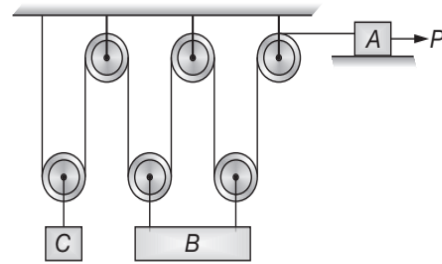

ARCHIVE: JEE MAIN

1. [Online April 2019]

If 10^{22} gas molecules each of mass 10^{-26} kg collide with a surface (perpendicular to it) elastically per second over an area 1 m^2 with a speed 10^4 ms^{-1} , the pressure exerted by the gas molecules will be of the order of

- (A) 1 Nm^{-2} (B) 2 Nm^{-2}
- (C) 3 Nm^{-2} (D) 4 Nm^{-2}

2. [Online April 2019]

A ball is thrown vertically up (taken as $+z$ -axis) from the ground. The correct momentum height (p - h) diagram is

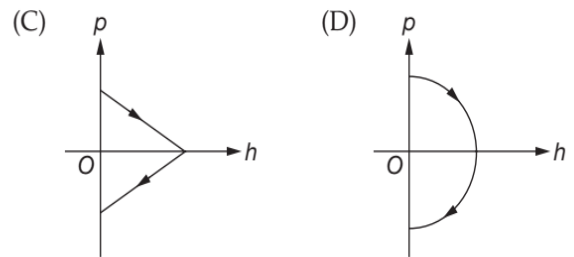
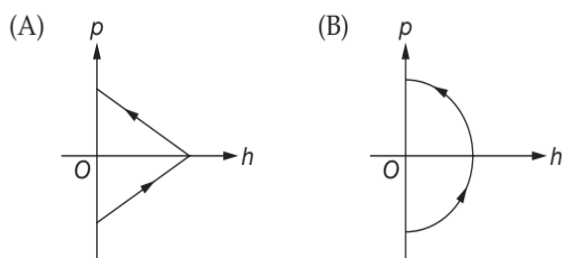

3. [Online April 2019]

A ball is thrown upward with an initial velocity V_0 from the surface of the earth. The motion of the ball is affected by a drag force equal to $m\gamma v^2$ (where m is mass of the ball, v is its instantaneous velocity and γ is a constant). Time taken by the ball to rise to its zenith is

- (A) $\frac{1}{\sqrt{\gamma g}} \sin^{-1} \left(\frac{\gamma V_0}{\sqrt{g}} \right)$ (B) $\frac{1}{\sqrt{\gamma g}} \ln \left(1 + \sqrt{\frac{\gamma}{g}} V_0 \right)$
- (C) $\frac{1}{\sqrt{\gamma g}} \tan^{-1} \left(\frac{\gamma V_0}{\sqrt{g}} \right)$ (D) $\frac{1}{\sqrt{2\gamma g}} \tan^{-1} \left(\sqrt{\frac{2\gamma}{g}} V_0 \right)$

4. [Online April 2019]

Two blocks A and B of masses $m_A = 1 \text{ kg}$ and $m_B = 3 \text{ kg}$ are kept on the table as shown in figure. The coefficient of friction between A and B is 0.2 and between B and the surface of the table is also 0.2 . The maximum force F that can be applied on B horizontally, so that the block A does not slide over the block B is [Take $g = 10 \text{ ms}^{-2}$]

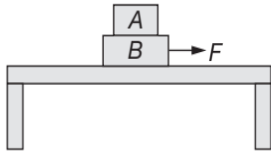

- (A) 40 N (B) 12 N
(C) 16 N (D) 8 N

5. [Online April 2019]

A block of mass 5 kg (i) pushed in case (A) and (ii) pulled in case (B), by a force $F = 20 \text{ N}$, making an angle of 30° with the horizontal, as shown in the figures. The coefficient of friction between the block and floor is $\mu = 0.2$. The difference between the accelerations of the block, in case (B) and case (A) will be ($g = 10 \text{ ms}^{-2}$)

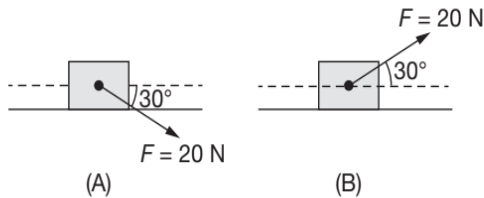

- (A) 0.4 ms^{-2} (B) 3.2 ms^{-2}
(C) 0 ms^{-2} (D) 0.8 ms^{-2}

6. [Online April 2019]

A spring whose unstretched length is l has a force constant k . The spring is cut into two pieces of unstretched lengths l_1 and l_2 where, $l_1 = nl_2$ and n is an integer. The ratio $\frac{k_1}{k_2}$ of the corresponding force constants, k_1 and k_2 will be

- (A) n^2 (B) $\frac{1}{n^2}$
(C) n (D) $\frac{1}{n}$

7. [Online April 2019]

A smooth wire of length $2\pi r$ is bent into a circle and kept in a vertical plane. A bead can slide smoothly on the wire. When the circle is rotating with angular

speed ω about the vertical diameter AB , as shown in figure, the bead is at rest with respect to the circular ring at position P as shown. Then the value of ω^2 is equal to

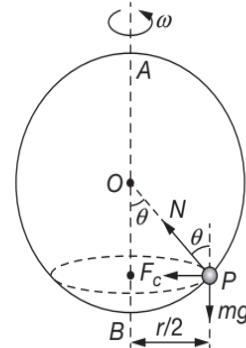

- (A) $\frac{(g\sqrt{3})}{r}$ (B) $\frac{2g}{r}$
(C) $\frac{2g}{(r\sqrt{3})}$ (D) $\frac{\sqrt{3}g}{2r}$

8. [Online January 2019]

A block of mass 10 kg is kept on a rough inclined plane as shown in the figure. A force of 3 N is applied on the block. The coefficient of static friction between the plane and the block is 0.6 . What should be the minimum value of force P , such that the block does not move downward? (Take $g = 10 \text{ ms}^{-2}$)

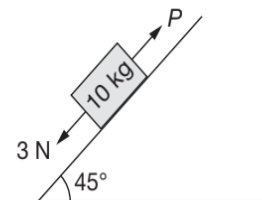

- (A) 25 N (B) 32 N
(C) 18 N (D) 23 N

9. [Online January 2019]

A mass of 10 kg is suspended vertically by a rope from the roof. When a horizontal force is applied on the roof at some point, the rope deviated at an angle of 45° at the roof point. If the suspended mass is at equilibrium, the magnitude of the force applied is ($g = 10 \text{ ms}^{-2}$)

- (A) 100 N (B) 200 N
(C) 70 N (D) 140 N

10. [Online January 2019]

A particle of mass m is moving in a straight line with momentum p . Starting at time $t = 0$, a force $F = kt$ acts in the same direction on the moving particle during

6.198 JEE Advanced Physics: Mechanics - I

time interval T so that its momentum changes from p to $3p$. Here k is a constant. The value of T is

- (A) $\sqrt{\frac{2k}{p}}$ (B) $2\sqrt{\frac{p}{k}}$
 (C) $\sqrt{\frac{2p}{k}}$ (D) $2\sqrt{\frac{k}{p}}$

11. [Online January 2019]

A particle moves from the point $(2.0\hat{i} + 4.0\hat{j})$ m, at $t = 0$, with an initial velocity $(5.0\hat{i} + 4.0\hat{j})$ ms⁻¹. It is acted upon by a constant force which produces a constant acceleration $(4.0\hat{i} + 4.0\hat{j})$ ms⁻². What is the distance of the particle from the origin at time 2 s ?

- (A) $20\sqrt{2}$ m (B) 15 m
 (C) $10\sqrt{2}$ m (D) 5 m

12. [Online January 2019]

A block kept on a rough inclined plane, as shown in the figure, remains at rest upto a maximum force 2 N down the inclined plane. The maximum external force up the inclined plane that does not move the block is 10 N. The coefficient of static friction between the block and the plane is [Take $g = 10$ ms⁻²]

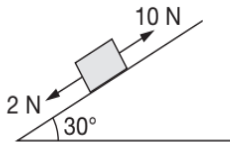

- (A) $\frac{1}{2}$ (B) $\frac{\sqrt{3}}{2}$
 (C) $\frac{\sqrt{3}}{4}$ (D) $\frac{2}{3}$

13. [2018]

Two masses $m_1 = 5$ kg and $m_2 = 10$ kg, connected by an inextensible string over a frictionless pulley, are moving as shown in the figure.

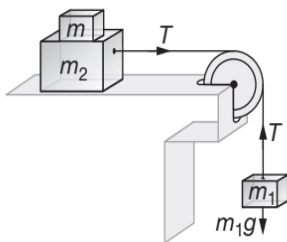

The coefficient of friction of horizontal surface is 0.15. The minimum weight m that should be put on top of m_2 to stop the motion is

- (A) 18.3 kg (B) 27.3 kg
 (C) 43.3 kg (D) 10.3 kg

14. [Online 2018]

A given object takes n times more time to slide down a 45° rough inclined plane as it takes to slide down a perfectly smooth 45° incline. The coefficient of kinetic friction between the object and the incline is

- (A) $\sqrt{1 - \frac{1}{n^2}}$ (B) $1 - \frac{1}{n^2}$
 (C) $\frac{1}{2 - n^2}$ (D) $\sqrt{\frac{1}{1 - n^2}}$

15. [Online 2018]

A body of mass 2 kg slides down with an acceleration of 3 ms⁻² on a rough inclined plane having a slope of 30° . The external force required to take the same body up the plane with the same acceleration will be ($g = 10$ ms⁻²)

- (A) 6 N (B) 14 N
 (C) 4 N (D) 20 N

16. [Online 2017]

Two particles A and B of equal mass M are moving with the same speed v as shown in the figure. They collide completely inelastically and move as a single particle C . The angle θ that the path, C makes with the X -axis is given by

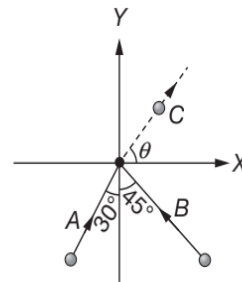

- (A) $\tan\theta = \frac{\sqrt{3} + \sqrt{2}}{1 - \sqrt{2}}$ (B) $\tan\theta = \frac{1 - \sqrt{3}}{1 + \sqrt{2}}$
 (C) $\tan\theta = \frac{\sqrt{3} - \sqrt{2}}{1 - \sqrt{2}}$ (D) $\tan\theta = \frac{1 - \sqrt{2}}{\sqrt{2}(1 + \sqrt{3})}$

17. [Online 2017]

A conical pendulum of length 1 m makes an angle $\theta = 45^\circ$ w.r.t. Z -axis and moves in a circle in the XY plane. The radius of the circle is 0.4 m and its center is vertically below O . The speed of the pendulum, in its circular path, will be (Take $g = 10$ ms⁻²)

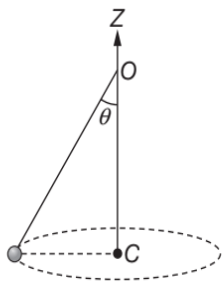

- (A) 0.4 ms^{-1} (B) 2 ms^{-1}
 (C) 0.2 ms^{-1} (D) 4 ms^{-1}

18. [Online 2016]

A rocket is fired vertically from the earth with an acceleration of $2g$, where g is the gravitational acceleration. On an inclined plane inside the rocket, making an angle θ with the horizontal, a point object of mass m is kept. The minimum coefficient of friction μ_{\min} between the mass and the inclined surface such that the mass does not move is

- (A) $\tan 2\theta$ (B) $\tan \theta$
 (C) $3 \tan \theta$ (D) $2 \tan \theta$

19. [Online 2016]

A particle of mass m is acted upon by a force F given by the empirical law $F = \frac{R}{t^2}v(t)$. If this law is to be tested experimentally by observing the motion starting from rest, the best way is to plot

- (A) $\log v(t)$ against $\frac{1}{t}$ (B) $v(t)$ against t^2
 (C) $\log v(t)$ against $\frac{1}{t^2}$ (D) $\log v(t)$ against t

20. [2015]

Given in the figure are two blocks A and B of weight 20 N and 100 N, respectively. These are being pressed against a wall by a force F as shown. If the coefficient of friction between the blocks is 0.1 and between block B and the wall is 0.15, the frictional force applied by the wall on block B is

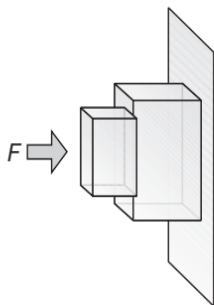

- (A) 120 N (B) 150 N
 (C) 100 N (D) 80 N

21. [Online 2015]

A block of mass $m = 10 \text{ kg}$ rests on a horizontal table. The coefficient of friction between the block and the table is 0.05. When hit by a bullet of mass 50 g moving with speed v , that gets embedded in it, the block moves and comes to stop after moving a distance of 2 m on the table. If a freely falling object were to acquire speed $\frac{v}{10}$ after being dropped from height H , then neglecting energy losses and taking $g = 10 \text{ ms}^{-2}$, the value of H is close to

- (A) 0.2 km (B) 0.3 km
 (C) 0.04 km (D) 0.5 km

22. [Online 2015]

A large number (n) of identical beads, each of mass m and radius r are strung on a thin smooth rigid horizontal rod of length $L (L \gg r)$ and are at rest at random positions. The rod is mounted between two rigid supports (shown in figure). If one of the beads is now given a speed v , the average force experienced by each support after a long time is (assume all collisions are elastic)

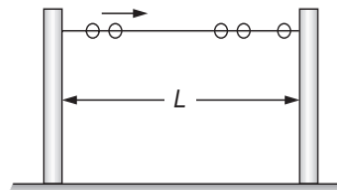

- (A) $\frac{mv^2}{L - nr}$ (B) $\frac{mv^2}{L - 2nr}$
 (C) $\frac{mv^2}{2(L - nr)}$ (D) zero

23. [2014]

A block of mass m is placed on a surface with a vertical cross section given by $y = \frac{x^3}{6}$. If the coefficient of friction is 0.5, the maximum height above the ground at which the block can be placed without slipping is

- (A) $\frac{1}{2}m$ (B) $\frac{1}{6}m$
 (C) $\frac{2}{3}m$ (D) $\frac{1}{3}m$

24. [2012]

Two cars of masses m_1 and m_2 are moving in circles of radii r_1 and r_2 , respectively. Their speeds are such that they make complete circles in the same time t . The ratio of their centripetal acceleration is

6.200 JEE Advanced Physics: Mechanics - I

- (A) $m_1 : m_2$ (B) $r_1 : r_2$
 (C) 1 : 1 (D) $m_1 r_1 : m_2 r_2$

25. [2012]

A particle of mass m is at rest at the origin at time $t = 0$. It is subjected to a force $F(t) = F_0 e^{-bt}$ in the x direction. Its speed $v(t)$ is depicted by which of the following curves?

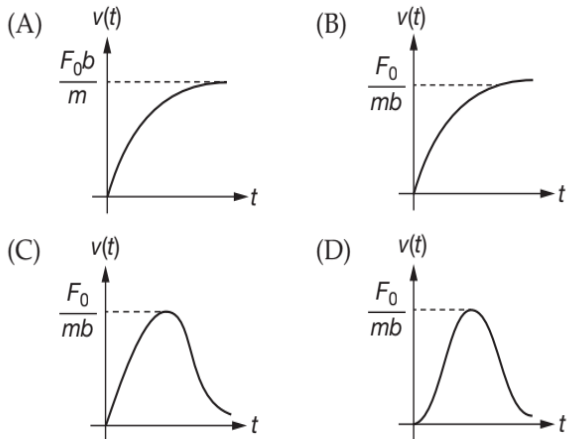

26. [2010]

Two fixed frictionless inclined planes making an angle 30° and 60° with the vertical are shown in the figure. Two blocks A and B are placed on the two planes. What is the relative vertical acceleration of A with respect to B ?

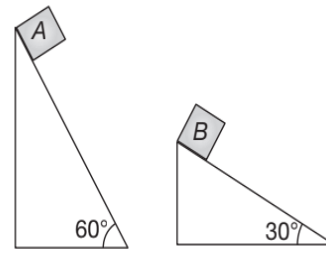

- (A) 4.9 ms^{-2} in vertical direction
 (B) 4.9 ms^{-2} in horizontal direction
 (C) 9.8 ms^{-2} in vertical direction
 (D) zero

27. [2010]

The figure shows the position-time ($x-t$) graph of one-dimensional motion of a body of mass 0.4 kg . The magnitude of each impulse is

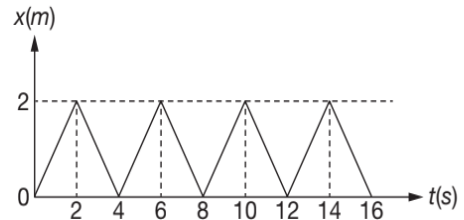

- (A) 0.2 Ns (B) 0.4 Ns
 (C) 0.8 Ns (D) 1.6 Ns

ARCHIVE: JEE ADVANCED

Single Correct Choice Type Problems

In this section each question has four choices (A), (B), (C) and (D), out of which ONLY ONE is correct.

1. [JEE (Advanced) 2016]

A uniform wooden stick of mass 1.6 kg and length l rests in an inclined manner on a smooth, vertical wall of height $h (< l)$ such that a small portion of the stick extends beyond the wall. The reaction force of the wall on the stick is perpendicular to the stick. The stick makes an angle of 30° with the wall and the bottom of the stick is on a rough floor. The reaction of the wall on the stick is equal in magnitude to the reaction of the floor on the stick. The ratio $\frac{h}{l}$ and the frictional force f at the bottom of the stick are ($g = 10 \text{ ms}^{-2}$)

- (A) $\frac{h}{l} = \frac{\sqrt{3}}{16}, f = \frac{16\sqrt{3}}{3} \text{ N}$
 (B) $\frac{h}{l} = \frac{3}{16}, f = \frac{16\sqrt{3}}{3} \text{ N}$

2. [JEE (Advanced) 2014]

A block of mass $m_1 = 1 \text{ kg}$ another mass $m_2 = 2 \text{ kg}$ are placed together (shown in figure) on an inclined plane with angle of inclination θ . Various values of θ are given in List-I. The coefficient of friction between the block m_1 and the plane is always zero. The coefficient of static and dynamic friction between the block m_2 and the plane are equal to $\mu = 0.3$.

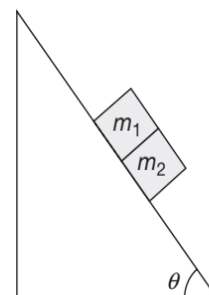

- (C) $\frac{h}{l} = \frac{3\sqrt{3}}{16}, f = \frac{8\sqrt{3}}{3} \text{ N}$
 (D) $\frac{h}{l} = \frac{3\sqrt{3}}{16}, f = \frac{16\sqrt{3}}{3} \text{ N}$

In List-II expressions for the friction on the block m_2 are given. Match the correct expression of the friction in List-II with the angles given in List-I and choose the correct option. The acceleration due to gravity is denoted by g .

(Useful information $\tan(5.5^\circ) \approx 0.1$; $\tan(11.5^\circ) \approx 0.2$; $\tan(16.5^\circ) \approx 0.3$)

List-I	List-II
P. $\theta = 5^\circ$	1. $m_2 g \sin \theta$
Q. $\theta = 10^\circ$	2. $(m_1 + m_2) g \sin \theta$
R. $\theta = 15^\circ$	3. $\mu m_2 g \cos \theta$
S. $\theta = 20^\circ$	4. $\mu (m_1 + m_2) g \cos \theta$

- (A) P-1, Q-1, R-1, S-3 (B) P-2, Q-2, R-2, S-3
 (C) P-2, Q-2, R-2, S-4 (D) P-2, Q-2, R-3, S-3

3. [IIT-JEE 2011]

A ball of mass (m) 0.5 kg is attached to the end of a string having length (l) 0.5 m. The ball is rotated on a horizontal circular path about vertical axis. The maximum tension that the string can bear is 324 N. The maximum possible value of angular velocity of ball (in rads^{-1}) is

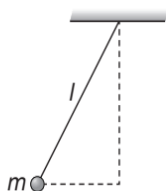

- (A) 9 (B) 18
 (C) 27 (D) 36

4. [IIT-JEE 2010]

A block of mass m is on an inclined plane of angle θ . The coefficient of friction between the block and the plane is μ and $\tan \theta > \mu$. The block is held stationary by applying a force P parallel to the plane. The direction of force pointing up the plane is taken to be positive. As P is varied from $P_1 = mg(\sin \theta - \mu \cos \theta)$ to $P_2 = mg(\sin \theta + \mu \cos \theta)$, the frictional force f versus P graph will look like

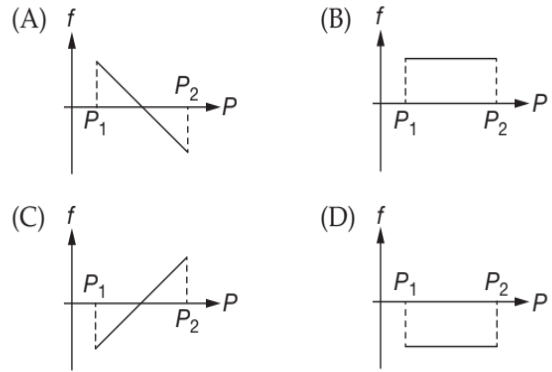
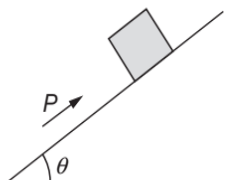

5. [IIT-JEE 2009]

A piece of wire is bent in the shape of a parabola $y = kx^2$ (y -axis vertical) with a bead of mass m on it. The bead can slide on the wire without friction. It stays at the lowest point of the parabola when the wire is at rest. The wire is now accelerated parallel to the x -axis with a constant acceleration a . The distance of the new equilibrium position of the bead, where the bead can stay at rest with respect to the wire, from the y -axis is

- (A) $\frac{a}{gk}$ (B) $\frac{a}{2gk}$
 (C) $\frac{2a}{gk}$ (D) $\frac{a}{4gk}$

6. [IIT-JEE 2007]

Two particles of mass m each are tied at the ends of a light string of length $2a$. The whole system is kept on a frictionless horizontal surface with the string held tight so that each mass is at a distance a from the centre P (as shown in the figure). Now, the mid-point of the string is pulled vertically upwards with a small but constant force F . As a result, the particles move towards each other on the surface. The magnitude of acceleration, when the separation between them becomes $2x$, is

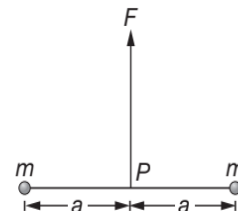

- (A) $\frac{F}{2m} \frac{a}{\sqrt{a^2 - x^2}}$ (B) $\frac{F}{2m} \frac{x}{\sqrt{a^2 - x^2}}$
 (C) $\frac{F}{2m} \frac{x}{a}$ (D) $\frac{F}{2m} \frac{\sqrt{a^2 - x^2}}{x}$

6.202 JEE Advanced Physics: Mechanics - I

7. [IIT-JEE 2006]

System shown in figure is in equilibrium and at rest. The spring and string are massless, now the string is cut. The acceleration of mass $2m$ and m just after the string is cut will be

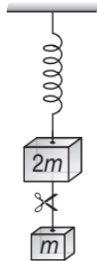

- (A) $\frac{g}{2}$ upwards, g downwards
- (B) g upwards, $\frac{g}{2}$ downwards
- (C) g upwards, $2g$ downwards
- (D) $2g$ upwards, g downwards

8. [IIT-JEE 2005]

A block of mass m is at rest under the action of force F against a wall as shown in figure. Which of the following statement is incorrect?

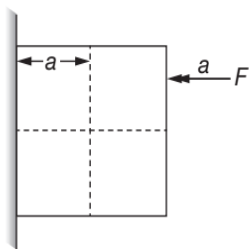

- (A) $f = mg$ [where f is the frictional force]
- (B) $F = N$ [where N is the normal force]
- (C) F will not produce torque
- (D) N will not produce torque

9. [IIT-JEE 2004]

A block P of mass m is placed on a horizontal frictionless plane. A second block of same mass m is placed on it and is connected to a spring of spring constant k , the two blocks are pulled by distance A . Block Q oscillates without slipping. What is the maximum value of frictional force between the two blocks?

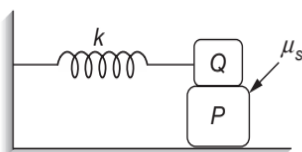

- (A) $\frac{kA}{2}$
- (B) kA
- (C) $\mu_s mg$
- (D) zero

10. [IIT-JEE 2003]

The maximum value of the force F such that the block shown in the arrangement, does not move is

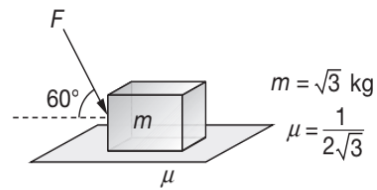

- (A) 20 N
- (B) 10 N
- (C) 12 N
- (D) 15 N

11. [IIT-JEE 2001]

The pulleys and strings shown in the figure are smooth and of negligible mass. For the system to remain in equilibrium, the angle θ should be

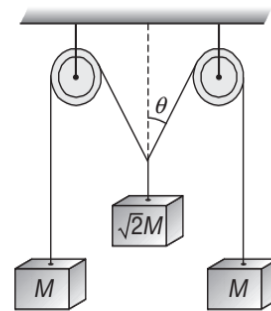

- (A) 0°
- (B) 30°
- (C) 45°
- (D) 60°

12. [IIT-JEE 2001]

A string of negligible mass going over a clamped pulley of mass m supports a block of mass M as shown in the figure. The force on the pulley by the clamp is given by

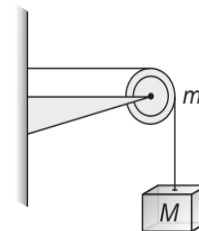

- (A) $\sqrt{2}Mg$
- (B) $\sqrt{2}mg$
- (C) $\sqrt{(M+m)^2 + m^2}g$
- (D) $\sqrt{(M+m)^2 + M^2}g$

13. [IIT-JEE 2001]

An insect crawls up a hemispherical surface very slowly as shown in figure. The coefficient of friction between the surface and the insect is $\frac{1}{3}$. If the line joining the centre of the hemispherical surface to the insect makes an angle α with the vertical, the maximum possible value of α is given by

Multiple Correct Choice Type Problems

In this section each question has four choices (A), (B), (C) and (D), out of which ONE OR MORE is/are correct.

1. [JEE (Advanced) 2014]

In the figure, a ladder of mass m is shown leaning against a wall. It is in static equilibrium making an angle θ with the horizontal floor. The coefficient of friction between the wall and the ladder is μ_1 and that between the floor and the ladder is μ_2 . The normal reaction of the wall on the ladder is N_1 and that of the floor is N_2 . If the ladder is about to slip, then

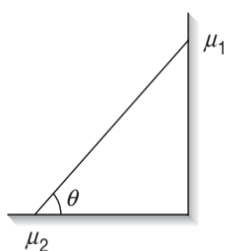

- (A) $\mu_1 = 0, \mu_2 \neq 0$ and $N_2 \tan \theta = \frac{mg}{2}$
 (B) $\mu_1 \neq 0, \mu_2 = 0$ and $N_1 \tan \theta = \frac{mg}{2}$
 (C) $\mu_1 \neq 0, \mu_2 \neq 0$ and $N_2 = \frac{mg}{1 + \mu_1 \mu_2}$
 (D) $\mu_1 = 0, \mu_2 \neq 0$ and $N_1 \tan \theta = \frac{mg}{2}$

2. [IIT-JEE 2012]

A small block of mass of 0.1 kg lies on a fixed inclined plane PQ which makes an angle θ with the horizontal. A horizontal force of 1 N acts on the block through its centre of mass as shown in the figure. The block remains stationary if (take $g = 10 \text{ ms}^{-2}$)

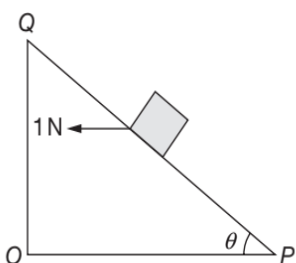

- (A) $\theta = 45^\circ$.
 (B) $\theta > 45^\circ$ and a frictional force acts on the block towards P .

- (C) $\theta > 45^\circ$ and a frictional force acts on the block towards Q .
 (D) $\theta < 45^\circ$ and a frictional force acts on the block towards Q .

3. [IIT-JEE 1986]

A simple pendulum of length L and mass (bob) M is oscillating in a plane about a vertical line between angular limits $-\phi$ and $+\phi$. For an angular displacement θ ($|\theta| < \phi$), the tension in the string and the velocity of the bob are T and V respectively. The following relations hold good under the above conditions

- (A) $T \cos \theta = Mg$
 (B) $T - Mg \cos \theta = \frac{MV^2}{L}$
 (C) The magnitude of the tangential acceleration of the bob $|a_T| = g \sin \theta$.
 (D) $T = Mg \cos \theta$

4. [IIT-JEE 1986]

A reference frame attached to the earth

- (A) is an inertial frame by definition.
 (B) cannot be an inertial frame because of revolution of earth round the sun.
 (C) is an inertial frame because Newton's laws are applicable in this frame.
 (D) cannot be an inertial frame because of rotation of earth about its own axis.

Integer/Numerical Answer Type Questions

In this section, the answer to each question is a numerical value obtained after doing series of calculations based on the data given in the question(s).

1. [JEE (Advanced) 2018]

A solid horizontal surface is covered with a thin layer of oil. A rectangular block of mass $m = 0.4 \text{ kg}$ is at rest on this surface. An impulse of 1 Ns is applied to the block at time $t = 0$, so that it starts moving along the X -axis with a velocity $v(t) = v_0 e^{-t/\tau}$, where v_0 is a constant and $\tau = 4 \text{ s}$. The displacement of the block, in metres, at $t = \tau$ is (Take, $e^{-1} = 0.37$) [Round off your answer to nearest integer].

2. [IIT-JEE 2011]

A block is moving on an inclined plane making an angle 45° with the horizontal and the coefficient of friction is μ . The force required to just push it up the inclined plane is 3 times the force required to just prevent it from sliding down. If we define $N = 10\mu$, then N is

- (C) Statement I is true and statement II is false.
 (D) Statement II is correct and statement I is false.

Assertion and Reasoning Type Problems

For the following Assertion-Reason type questions given below, choose the correct option:

- (A) Both statement I & II are correct and statement II is correct explanation of statement I.
 (B) Both statement I & II are correct and statement II is not correct explanation of statement I.

1. [JEE (Advanced) 2008]

Statement-I: It is easier to pull a heavy object than to push it on a level ground.

Statement-II: The magnitude of frictional force depends on the nature of the two surfaces in contact.

2. [JEE (Advanced) 2007]

Statement-I: A cloth covers a table. Some dishes are kept on it. The cloth can be pulled out without dislodging the dishes from the table.

Statement-II: For every action there is an equal and opposite reaction.

ANSWER KEYS—TEST YOUR CONCEPTS AND PRACTICE EXERCISES
**Test Your Concepts-I
(Based on Impulse Momentum)**

- 150 N
- 4.5 kgms^{-1}
- (a) 20 Ns
(b) 8 kN
(c) 16 kN
- 15 N
- 600 N

**Test Your Concepts-II
(Based on Constraints)**

- 3 ms^{-1}
- 1.5 ms^{-1}
- 0
- $-\frac{L^2 v_A^2}{(L^2 - y^2)^{3/2}}$
- 4 ms^{-2}
- $\frac{v}{h} \sin^2 \theta$
- 2
- 2 ms^{-2}
- 0.4 ms^{-1} (down)
- $\frac{s + \sqrt{2x}}{x + \sqrt{2s}} v_A$
- $v_A \sqrt{\frac{2x^2 + h^2}{x^2 + h^2}}$
- $-\frac{3y}{2\sqrt{y^2 + b^2}} v_A$
- 1.8 ms^{-1} , down
- 45 cms^{-1} , upwards
- 1 ms^{-1} , upwards ; 0.5 ms^{-2} , downwards
- 0.25 ms^{-1}
- (a) 0
(b) 5 ms^{-2}

- 6 m
- 0.5 ms^{-1}
- $2v_0$, downwards
- 4.36 ms^{-2}
- $\sqrt{31}a_0$
- $u \sec \theta$
- $\frac{2v \sin^2\left(\frac{\alpha}{2}\right)}{\cos \alpha}$
- 0.5 ms^{-1} , 0.75 ms^{-2} , 1 ms^{-1}

**Test Your Concepts-IV (Based on Newton's
Laws of Motion: Accelerated Systems)**

- $4\sqrt{5} \text{ ms}^{-1}$
- $\frac{mg}{2} \sin(2\theta)$
- $\left(\frac{m_1 \sin \alpha - 2m_2}{m_1 + 4m_2}\right)g$, $2\left(\frac{m_1 \sin \alpha - 2m_2}{m_1 + 4m_2}\right)g$
- 4.21 N , 5.79 ms^{-2} , downwards; 6.84 ms^{-2} , upwards
- $\frac{2g(2\eta - \sin \theta)}{4\eta + 1}$
- $\sqrt{\frac{2l(\eta + 4)}{3g(2 - \eta)}}$
- (a) 4.1 ms^{-2}
(b) Tension in the string between A and B = 4.56 N
Tension in the string between B and C = 18.2 N
- (a) 4 ms^{-2}
(b) 4 N
- 4 N
- 5.5 ms^{-2}
- $\frac{mg \cos \alpha \sin \alpha}{\left(m \sin \alpha + \frac{M}{\sin \alpha}\right)}$, $\frac{mg \cos \alpha}{m \sin \alpha + \frac{M}{\sin \alpha}}$
- 2.5 ms^{-2}
- 2.34 ms^{-2} , 1.558 ms^{-2} and 81.8 N

15. $\frac{4F - (M + m)g}{M + m}$
17. 20 cm
18. 10 ms^{-1}
19. $\left(\frac{5m - M}{25m - M}\right)g, 5\left(\frac{5m - M}{25m - M}\right)g$
20. $\frac{2m_1m_3g}{(m_2 + m_3)(m_1 + m_2) + m_2m_3}$
21. 735 N, 245 N, mode (b)

Test Your Concepts-V (Based on Equilibrium)

1. $\frac{2Mg}{\sqrt{3}}, \frac{Mg}{\sqrt{3}}$
2. $2[(\sqrt{3} + 1)\hat{i} + (4 + \sqrt{3})\hat{j}] \text{ N}$
3. mg
4. $\frac{4}{\sqrt{3}} \text{ N}, \frac{20}{\sqrt{3}} \text{ N}$
5. $\frac{mg}{A}$
6. $5\sqrt{3} \text{ N}$
7. $10\sqrt{2} \text{ N}, 5\sqrt{2} \text{ N}$

Test Your Concepts-VI (Based on Non-inertial Frames: Pseudo Force)

1. $(g + a)\sin\theta$, down the plane
2. $(M_1 + M_2 + M_3)\frac{M_3}{M_2}g$
3. $a_0\sqrt{\frac{m}{k}}$
4. Acceleration of A is $\frac{g}{8}$ in horizontal direction and $\frac{5g}{8}$ in vertical direction.
Acceleration of B is $\frac{g}{2}$ in horizontal direction (leftwards) and acceleration of C is $\frac{g}{8}$ in horizontal direction (rightwards).
5. 5.66 ms^{-2}
6. $\frac{3g}{4}$

7. $30^\circ, 20 \text{ N}$
8. $\tan^{-1}\left(\frac{2}{\sqrt{3}}\right), 10\sqrt{7} \text{ N}$
9. $mg \cos^2\theta$
11. $\frac{m_0 + m}{\cot\theta - 1}$

Test Your Concepts-VII (Based on Friction)

1. $0.134r$
2. $\frac{1}{\sqrt{3}}$
3. 2.7 ms^{-2}
4. 3.16 s
5. $\frac{mg(\sin\theta + \mu \cos\theta)}{\sqrt{\mu^2 + 1}}$
6. 8.5 m
7. $a_A = 1.489 \text{ ms}^{-2}$
 $a_B = 0.744 \text{ ms}^{-2}$
 $T = 107.74 \text{ N}$
8. $g(\sin\theta - \sqrt{2}\mu_K \cos\theta)$
9. $\sqrt{\frac{2F}{\rho} - \mu_K g L}$
10. (a) 6.63 ms^{-2}
(b) 0.33 m
11. (a) $\sqrt{\frac{22(\mu_2 - \mu_1)gl}{10}}$
(b) $\sqrt{\frac{20l}{11(\mu_2 - \mu_1)g}}$
13. 2.77 m
14. $a_A = 21 \text{ ms}^{-2}, a_B = 1.6 \text{ ms}^{-2}$
15. 1.33 ms^{-2}
16. (a) $\frac{F}{2\sqrt{3}}$
(b) 15.27 N
17. $\frac{(M + m)}{\mu - 1}, \mu > 1$

6.208 JEE Advanced Physics: Mechanics - I

18. $\frac{(\mu + 1)g}{\frac{2}{M_3} + \frac{1}{2M_1} + \frac{1}{2M_2}}$

19. 0.06 ms^{-2}

21. $a_A = a_C = \frac{g(m_3 - \mu(2m_2 + m_1))}{m_1 + m_3}$

22. 0.288

**Test Your Concepts-VIII
(Based on Circular Motion)**

1. $v = \omega\sqrt{L^2 - a^2}$

2. (a) $\frac{mv^2}{R}$

(b) $\frac{\mu mv^2}{R}$

(c) $\frac{\mu v^2}{R}$

(d) $v_0 e^{-2\pi\mu}$

3. $\sqrt{\frac{2m_1\mu g}{(m_1 - m_2)R}}, 30 \text{ N}$

4. (a) $\sqrt{\frac{\mu g}{L}}$

(b) $\left(\left(\frac{\mu g}{L}\right)^2 - \alpha^2\right)^{\frac{1}{4}}$

5. (a) 275.4 N

(b) 877.3 N

6. (a) 74°

(b) No

7. $\frac{3\pi a}{u}$

9. $4.08 \text{ ms}^{-1} \leq v \leq 15 \text{ ms}^{-1}$

10. $\omega_{\min} = \sqrt{\frac{g(1 - \mu \tan \theta)}{b \tan \theta (\mu + \tan \theta)}}$,

$\omega_{\max} = \sqrt{\frac{g(1 + \mu \tan \theta)}{b \tan \theta (\tan \theta - \mu)}}$

12. $\frac{v_0}{\left(1 + \frac{\mu v_0 t}{R}\right)}$

13. $n_{\max} = \frac{1}{2\pi} \sqrt{\frac{g(\sin \theta + \mu \cos \theta)}{r(\cos \theta - \mu \sin \theta)}}$,

$n_{\min} = \frac{1}{2\pi} \sqrt{\frac{g(\sin \theta - \mu \cos \theta)}{r(\cos \theta + \mu \sin \theta)}}$

Single Correct Choice Type Questions

1. B	2. B	3. C	4. D	5. A	6. C	7. C	8. C	9. D	10. B
11. D	12. C	13. D	14. C	15. C	16. A	17. C	18. C	19. B	20. D
21. C	22. B	23. A	24. D	25. D	26. C	27. C	28. B	29. D	30. B
31. B	32. D	33. C	34. B	35. B	36. A	37. A	38. D	39. C	40. A
41. C	42. C	43. A	44. C	45. D	46. D	47. D	48. D	49. A	50. B
51. C	52. C	53. A	54. C	55. A	56. D	57. A	58. B	59. D	60. C
61. B	62. D	63. D	64. D	65. A	66. A	67. D	68. A	69. C	70. A
71. A	72. B	73. C	74. C	75. C	76. D	77. D	78. D	79. C	80. D
81. C	82. D	83. C	84. C	85. C	86. B	87. C	88. D	89. D	90. D
91. B	92. D	93. D	94. B	95. A	96. B	97. B	98. B	99. C	100. B
101. B	102. C	103. B	104. C	105. C	106. C	107. A	108. C	109. D	110. A
111. C	112. B	113. D	114. D	115. C	116. A	117. B	118. D	119. D	120. D
121. B	122. C	123. A	124. C	125. B	126. A	127. A	128. A	129. A	130. A
131. C	132. C	133. B	134. C	135. C	136. A	137. C	138. C	139. D	140. A

141. C	142. C	143. C	144. C	145. A	146. C	147. B	148. B	149. D	150. D
151. A	152. A	153. C	154. C	155. B	156. C	157. D	158. B	159. B	160. B
161. B	162. D	163. D	164. D	165. C	166. A	167. C	168. C	169. A	170. C
171. B	172. B	173. B	174. B	175. D	176. C	177. C	178. C	179. D	180. D
181. A	182. A	183. C	184. B	185. A	186. B	187. A	188. C	189. D	190. C
191. B	192. D	193. A	194. A	195. C	196. A	197. B	198. A	199. B	200. D
201. A	202. A	203. B	204. D	205. D	206. D	207. B	208. B	209. C	210. B
211. C	212. D	213. B	214. D	215. D	216. B	217. B	218. B	219. D	220. C
221. C	222. C								

Multiple Correct Choice Type Questions

1. A, D	2. B, D	3. A, C	4. A, B, C	5. A
6. A, C, D	7. B, D	8. A, B, C	9. B, C, D	10. B, D
11. A, B, D	12. A, C	13. A, D	14. B, D	15. A, D
16. A	17. D	18. A, C, D	19. B, C	20. D
21. A, D	22. B, C	23. A, C	24. A, B, C, D	25. A, B
26. C	27. B, D	28. A, B, D	29. B, D	30. A, B, C, D
31. B, D	32. A, B	33. A, B	34. B, C, D	35. C, D
36. A, C, D	37. A, B	38. A, C	39. A, D	40. A, D
41. A, C	42. A, B, C, D	43. A, C	44. A, D	45. A, B
46. A, B, C	47. B, C, D	48. B, C	49. A, C	50. B, D
51. A, C	52. A, B	53. A, B, C	54. B, C, D	55. A, B
56. A, B, C	57. A, C	58. A, D	59. A, C, D	60. A, B, D
61. B, C	62. B, D	63. A, D	64. B, D	65. A, B, C
66. A, B, C				

Reasoning Based Questions

1. B	2. A	3. D	4. A	5. B	6. B	7. A	8. D	9. B	10. B
11. D	12. D	13. A	14. B	15. C	16. A	17. A	18. D	19. D	20. A
21. D	22. D	23. A	24. B	25. D					

Linked Comprehension Type Questions

1. B	2. A	3. B	4. D	5. C	6. A	7. D	8. C	9. B	10. C
11. D	12. C	13. D	14. B	15. C	16. D	17. B	18. C	19. B	20. D
21. A	22. D	23. C	24. B	25. D	26. B	27. B	28. C	29. B	30. D
31. A	32. B	33. B	34. B	35. D	36. C	37. C	38. D	39. A	40. C
41. D	42. D	43. A	44. B	45. B	46. C	47. A	48. A	49. B	50. B
51. C	52. C	53. B	54. A	55. C	56. C	57. D	58. B	59. C	60. B
61. A	62. A	63. B	64. B	65. A	66. B	67. A	68. B	69. C	70. C
71. D	72. A	73. C	74. D	75. A	76. C	77. B	78. B	79. B	80. B
81. D	82. C	83. B	84. B	85. A	86. B	87. A			

Matrix Match/Column Match Type Questions

1. $A \rightarrow (q)$	$B \rightarrow (r)$	$C \rightarrow (s)$	$D \rightarrow (p)$	
2. $A \rightarrow (p, u)$	$B \rightarrow (t)$	$C \rightarrow (r, s)$	$D \rightarrow (q, r)$	
3. $A \rightarrow (r)$	$B \rightarrow (s)$	$C \rightarrow (t)$	$D \rightarrow (q)$	
4. $A \rightarrow (t)$	$B \rightarrow (r)$	$C \rightarrow (p)$	$D \rightarrow (s)$	$E \rightarrow (q)$
5. $A \rightarrow (q)$	$B \rightarrow (s)$	$C \rightarrow (p, t)$	$D \rightarrow (r)$	
6. $A \rightarrow (r, s)$	$B \rightarrow (p, s)$	$C \rightarrow (p, s)$	$D \rightarrow (p, r, s)$	
7. $A \rightarrow (q, r)$	$B \rightarrow (p, s)$	$C \rightarrow (p, s)$	$D \rightarrow (q, r)$	
8. $A \rightarrow (r)$	$B \rightarrow (t)$	$C \rightarrow (q)$	$D \rightarrow (p)$	
9. $A \rightarrow (r)$	$B \rightarrow (t)$	$C \rightarrow (p)$	$D \rightarrow (q)$	
10. $A \rightarrow (s)$	$B \rightarrow (p)$	$C \rightarrow (t)$	$D \rightarrow (q)$	
11. $A \rightarrow (t, u)$	$B \rightarrow (p, u)$	$C \rightarrow (q, u)$	$D \rightarrow (s, u)$	
12. $A \rightarrow (p, q, r)$	$B \rightarrow (p, q, r)$	$C \rightarrow (p, q)$	$D \rightarrow (s)$	
13. $A \rightarrow (s)$	$B \rightarrow (r)$	$C \rightarrow (p)$	$D \rightarrow (q)$	
14. $A \rightarrow (p, s, t)$	$B \rightarrow (p, q, t)$	$C \rightarrow (p, t)$	$D \rightarrow (r)$	
15. $A \rightarrow (r)$	$B \rightarrow (p)$	$C \rightarrow (q)$	$D \rightarrow (s)$	
16. $A \rightarrow (p)$	$B \rightarrow (r)$	$C \rightarrow (q)$	$D \rightarrow (s)$	
17. $A \rightarrow (q, s)$	$B \rightarrow (p, s)$	$C \rightarrow (r)$	$D \rightarrow (r)$	

Integer/Numerical Answer Type Questions

1. 6	2. 10	3. 40	4. 125	5. 4
6. 400	7. 100	8. 3	9. (a) 2, (b) 6	10. 32
11. 100	12. 90	13. 16	14. 200	15. (a) 20, (b) 3600
16. (a) 54, (b) 59	17. 5	18. 6	19. 4220	20. 5
21. 5	22. 0	23. 18	24. 6	25. 4
26. 1	27. 8	28. 8	29. 0	30. 1
31. 2	32. 4	33. 8	34. 2	35. 8
36. 0	37. 5	38. 2	39. 4	40. 1
41. 5				

ARCHIVE: JEE MAIN

1. B	2. D	3. C	4. C	5. D	6. D	7. C	8. B	9. A	10. B
11. A	12. B	13. B	14. B	15. D	16. A	17. B	18. B	19. A	20. A
21. C	22. B	23. B	24. B	25. B	26. A	27. C			

ARCHIVE: JEE ADVANCED
Single Correct Choice Type Problems

1. D	2. D	3. D	4. A	5. B	6. B	7. A	8. D	9. A	10. A
11. C	12. D	13. A	14. A	15. A	16. B	17. C	18. A	19. A	20. C

Multiple Correct Choice Type Problems

1. C, D 2. A, C 3. B, C 4. B, D

Matrix Match/Column Match Type Questions

1. 6 2. 5

Assertion and Reasoning Type Problems

1. B 2. B