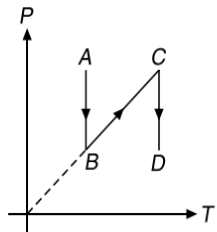
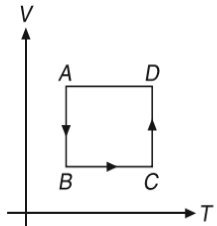
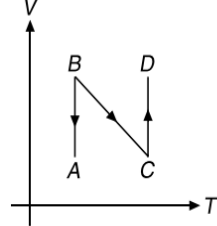

PRACTICE EXERCISES
SINGLE CORRECT CHOICE TYPE QUESTIONS

This section contains Single Correct Choice Type Questions. Each question has four choices (A), (B), (C) and (D), out of which ONLY ONE is correct.

- The efficiency of a Carnot engine operating between the temperatures T_1 and T_2 ($T_1 > T_2$) is η_0 . The temperature of sink is decreased by α K and efficiency is η_1 . The temperature of source is increased by α K and efficiency is η_2 .
 (A) $\eta_1 = \eta_2 = \eta_0$ (B) $\eta_1 > \eta_2 > \eta_0$
 (C) $\eta_1 < \eta_2 < \eta_0$ (D) $\eta_1 > \eta_0 > \eta_2$
- An ideal monatomic gas at 27°C is compressed adiabatically to $\frac{8}{27}$ of its original volume. Then the rise in temperature is
 (A) 450°C (B) 375°C
 (C) 225°C (D) 405°C
- One mole of an ideal gas undergoes a process $P = \frac{P_0}{1 + \left(\frac{V_0}{V}\right)^2}$. Here P_0 and V_0 are constants. Change in temperature of the gas when volume is changed from $V = V_0$ to $V = 2V_0$ is
 (A) $-\frac{2P_0V_0}{5R}$ (B) $\frac{11P_0V_0}{10R}$
 (C) $-\frac{5P_0V_0}{4R}$ (D) P_0V_0
- The temperature of an isolated body of mass m , gram specific heat c falls from T_1 to T_2 in time t .
 (A) $t = \frac{mc}{\sigma} \left(\frac{1}{T_2^3} - \frac{1}{T_1^3} \right)$ (B) $t = \frac{2mc}{\sigma} \left(\frac{1}{T_2^3} - \frac{1}{T_1^3} \right)$
 (C) $t = \frac{mc}{3\sigma} \left(\frac{1}{T_2^3} - \frac{1}{T_1^3} \right)$ (D) $t = \frac{3\sigma}{mc} \left(\frac{1}{T_2^3} - \frac{1}{T_1^3} \right)$
- Two moles of helium are mixed with n moles hydrogen. The root mean square (rms) speed of the gas molecules in the mixture is $\sqrt{2}$ times the speed of sound in the mixture. Then value of n is
 (A) 1 (B) 3
 (C) 2 (D) $\frac{3}{2}$
- When a gas A is introduced into an evacuated flask kept at 25°C , the pressure is found to be one atmosphere. If an equal mass of another gas B is then added to the same flask, the total pressure becomes 3 atm. Assuming ideal gas behaviour, calculate the ratio of molecular weights $M_A : M_B$
 (A) 1:1 (B) 2:1
 (C) 1:2 (D) 3:1
- An ideal gas ($\gamma = 1.5$) is expanded adiabatically. How many times has the gas to be expanded to reduce the root mean square velocity of molecules 2 times
 (A) 4 times (B) 16 times
 (C) 8 times (D) 2 times
- A solid copper sphere (density ρ and specific heat capacity c) of radius r at an initial temperature 200 K is suspended inside a chamber whose walls are at almost 0 K . The time required (in μs) for the temperature of the sphere to drop to 100 K is
 (A) $\frac{72}{7} \frac{r\rho c}{\sigma}$ (B) $\frac{7}{72} \frac{r\rho c}{\sigma}$
 (C) $\frac{27}{7} \frac{r\rho c}{\sigma}$ (D) $\frac{7}{27} \frac{r\rho c}{\sigma}$
- A vertical U-tube contains a liquid. When the two arms are maintained at different temperatures 50°C and 60°C , the levels of liquid in the two arms are 49 cm and 50 cm respectively. The coefficient of volume expansion of the liquid is
 (A) $1.2 \times 10^{-3} \text{ }^\circ\text{C}^{-1}$ (B) $1.4 \times 10^{-3} \text{ }^\circ\text{C}^{-1}$
 (C) $2.3 \times 10^{-3} \text{ }^\circ\text{C}^{-1}$ (D) $1.8 \times 10^{-3} \text{ }^\circ\text{C}^{-1}$
- Two metallic spheres P and Q of the same surface finish are taken. Weight of P is twice that of Q . Both the spheres are heated to the same temperature and are left in a room to cool by radiation. The ratio of the rate of cooling of P to that of Q is
 (A) $1:\sqrt{2}$ (B) $\sqrt{2}:1$
 (C) $1:(2)^{\frac{1}{3}}$ (D) $\frac{1}{2^{\frac{1}{3}}}:1$
- Select the corresponding V - T diagram for the P - T diagram shown in Figure.

(A) 

(B) 

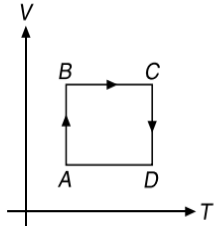
(C) 

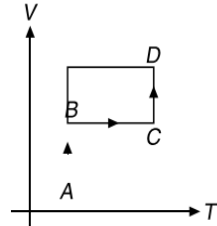
(D) 

12. Water is being boiled in a flat bottomed kettle placed on a stove. The area of the bottom is 300 cm^2 and the thickness is 2 mm . If the amount of steam produced is 1 g min^{-1} , then the difference of the temperature between the inner and the outer surfaces of the bottom is (thermal conductivity of the material of the kettle $= 0.5 \text{ cal cm}^{-1} \text{ s}^{-1} \text{ }^\circ\text{C}^{-1}$, latent heat of the steam is equal to 540 cal g^{-1})
- (A) $12 \text{ }^\circ\text{C}$ (B) $1.2 \text{ }^\circ\text{C}$
 (C) $0.12 \text{ }^\circ\text{C}$ (D) $0.012 \text{ }^\circ\text{C}$
13. In a given process of an ideal gas and $dQ < 0$. Then for the gas
- (A) the temperature will decrease
 (B) the volume will increase
 (C) the pressure will remain constant
 (D) the temperature will increase
14. 2 kg of ice at $-20 \text{ }^\circ\text{C}$ is mixed with 5 kg of water at $20 \text{ }^\circ\text{C}$ in an insulating vessel having a negligible heat capacity. Assuming that the specific heat of water, ice and latent heat of ice respectively are $1 \text{ kcal kg}^{-1} (\text{ }^\circ\text{C}^{-1})$, $0.5 \text{ kcal kg}^{-1} (\text{ }^\circ\text{C}^{-1})$ and 80 kcal kg^{-1} , then the final mass of water (in kg) left in the container is
- (A) 2 (B) 3
 (C) 6 (D) 12
15. In case of Boyle's Law, if the pressure increases by 1% , the percentage of decrease in volume is
- (A) 1% (B) $\left(\frac{100}{101}\right)\%$
 (C) $\left(\frac{1}{10}\right)\%$ (D) $\left(\frac{1}{100}\right)\%$
16. A body of mass 25 kg is dragged on a rough horizontal floor for one hour with a speed of 2 km h^{-1} . The coefficient of friction for the surfaces in contact is 0.5 and half the heat produced is absorbed by the body. If specific heat of body is $0.1 \text{ cal g}^{-1} (\text{ }^\circ\text{C}^{-1})$ and $g = 9.8 \text{ ms}^{-2}$, then the rise in temperature of body is
- (A) 39 K (B) 59.5 K
 (C) 84.5 K (D) 11.6 K
17. A mixture of 4 g helium and 28 g nitrogen is enclosed in a vessel at a constant temperature 300 K . The quantity of heat absorbed by the mixture to double the root-mean velocity of its molecule is
- (A) $4500R$ (B) $1800R$
 (C) $7200R$ (D) $3600R$
18. The energy density $\frac{U}{V}$ of an ideal monatomic gas is related to its pressure P as
- (A) $\frac{U}{V} = 3P$ (B) $\frac{U}{V} = \frac{3}{2}P$
 (C) $\frac{U}{V} = \frac{P}{3}$ (D) $\frac{U}{V} = \frac{5}{2}P$
19. A uniform solid brass sphere is rotating with angular speed ω_0 about a diameter. If its temperature is now increased by $100 \text{ }^\circ\text{C}$. What will be its new angular speed. (Given $\alpha_B = 2 \times 10^{-5} \text{ per } ^\circ\text{C}$)

- (A) $1.1 \omega_0$ (B) $1.01 \omega_0$
 (C) $0.996 \omega_0$ (D) $0.824 \omega_0$

20. In an ideal heat pump, heat from inside at 277 K is transferred to a room at 300 K . The amount of heat (in joule) which will be delivered to the room for each joule of electrical energy consumed is
- (A) 12 J (B) 1 J
 (C) 25 J (D) 13 J
21. Which of the following statement is true?
- (A) In a cyclic process, the internal energy of the gas increases.
 (B) Free expansion is a reversible process.
 (C) In a cyclic process, work done by the system is non-zero.
 (D) Efficiency of Carnot engine is 100% if temperature of sink is $0 \text{ }^\circ\text{C}$.
22. An insulator container contains 4 moles of an ideal diatomic gas at temperature T . Heat Q is supplied to this gas, due to which 2 moles of the gas are dissociated into atoms but temperature of the gas remains constant. Then
- (A) $Q = 2RT$ (B) $Q = RT$
 (C) $Q = 3RT$ (D) $Q = 4RT$

23. A closed cubical box made of perfectly insulating material has walls of thickness 8 cm and the only way for heat to enter or leave the box is through two solid metal plugs A and B , each of cross-sectional area 12 cm^2 and length 8 cm fixed in the opposite walls of the box as shown in the figure. Outer surface A is kept at $100 \text{ }^\circ\text{C}$ while the outer surface B is kept at $4 \text{ }^\circ\text{C}$. The thermal conductivity of the material of the plugs is $0.5 \text{ cal s}^{-1} \text{ cm}^{-1} (\text{ }^\circ\text{C}^{-1})$. A source of energy generating 36 cal s^{-1} is enclosed inside the box. The equilibrium temperature of the inner surface of the box (assuming that it is same at all points on the inner surface) is
- (A) $38 \text{ }^\circ\text{C}$ (B) $57 \text{ }^\circ\text{C}$
 (C) $76 \text{ }^\circ\text{C}$ (D) $85 \text{ }^\circ\text{C}$

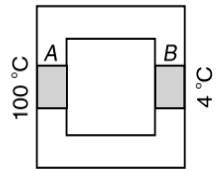

24. An ideal monatomic gas undergoes the process AB as shown in Figure.

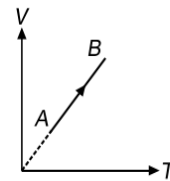

- If the heat supplied and the work done in the process are Q and W respectively, the ratio $Q : W$ is
- (A) $5 : 2$ (B) $5 : 3$
 (C) $3 : 2$ (D) $2 : 1$

25. The thermal conductivities of copper, mercury and glass are, respectively, K_C , K_M and K_G such that $K_C > K_M > K_G$. If the same quantity of heat flows per second per unit area of each and the corresponding temperature gradients are X_C , X_M and X_G , then

2.132 JEE Advanced Physics: Waves and Thermodynamics

- (A) $X_C = X_M = X_G$ (B) $X_C > X_M > X_G$
 (C) $X_C < X_M < X_G$ (D) $X_M > X_C > X_G$

26. Sixty percent of given sample of oxygen gas when raised to a high temperature dissociates into atoms. Ratio of its initial heat capacity (at constant volume) to the final heat capacity (at constant volume) will be

- (A) $\frac{8}{7}$ (B) $\frac{25}{26}$
 (C) $\frac{10}{7}$ (D) $\frac{25}{27}$

27. Two moles of an ideal monatomic gas is expanded according to relation $PT = \text{constant}$ from its initial state (P_0, V_0) to the final state, due to which its pressure becomes half of the initial pressure. The change in internal energy is

- (A) $\frac{3}{4}P_0V_0$ (B) $\frac{3}{2}P_0V_0$
 (C) $\frac{9}{2}P_0V_0$ (D) $\frac{5}{2}P_0V_0$

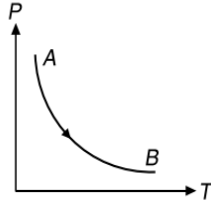

28. In a certain region of space there are n number of molecules per unit volume. The temperature of the gas is T . If k_B is the Boltzmann's Constant and R is the Universal Gas Constant, then the pressure of the gas will be

- (A) nRT (B) $nk_B T$
 (C) $\frac{nT}{k_B}$ (D) $\frac{nT}{R}$

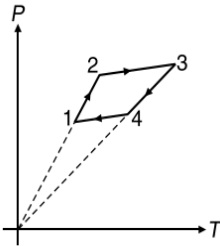

29. A ring consisting of two parts ADB and ACB of same conductivity K carries an amount of heat H . The ADB part is now replaced with another metal keeping the temperatures T_1 and T_2 constant. The heat carried increases to $2H$. The conductivity of the new ADB part if it is given that $\frac{ACB}{ADB} = 3$, is

- (A) $\frac{7}{3}K$ (B) $2K$
 (C) $\frac{5}{2}K$ (D) $3K$

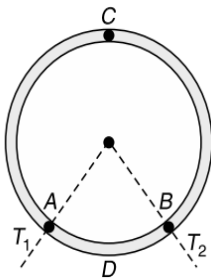

30. The specific heat of many solids at low temperatures varies with absolute temperature T according to the relation $S = AT^3$, where A is a constant. The heat energy required to raise the temperature of a mass m of such a solid from $T = 0$ to $T = 20$ K is

- (A) 4×10^4 mA (B) 2×10^3 mA
 (C) 8×10^6 mA (D) 2×10^6 mA

31. In the following graph for a given mass of gas, as temperature increases, volume

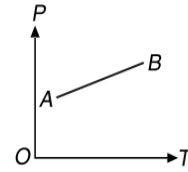

- (A) remains constant (B) decreases
 (C) increases (D) becomes zero

32. Three identical rods of same material are joined to form an equilateral triangle. The temperature of end A and B is maintained constant as $\sqrt{3}T$ and T . The ratio of $\frac{T_C}{T_B}$ will be (assuming no loss of heat from surfaces)

- (A) $\frac{1+\sqrt{3}}{2}$ (B) $\frac{1-\sqrt{3}}{2}$
 (C) $\frac{1+\sqrt{2}}{2}$ (D) $\frac{1-\sqrt{2}}{2}$

33. In the process $PV = \text{constant}$, pressure (P) versus density (ρ) graph of an ideal gas is

- (A) a straight line parallel to P -axis
 (B) a straight line parallel to ρ -axis
 (C) a straight line passing through origin
 (D) a parabola

34. A mass m of steam at 100°C is to be passed into a vessel containing 10 g of ice and 100 g of water at 0°C so that all the ice is melted and the temperature is raised to 5°C . Neglecting heat absorbed by the vessel, we get

- (A) $m = 2.1$ g (B) $m = 4.2$ g
 (C) $m = 6.3$ g (D) $m = 8.4$ g

35. Two processes A and B for a given sample of a gas are shown in Figure.

Let, Q_1 be the amount of heat absorbed in process A , Q_2 be the amount of heat absorbed in process B , ΔU_1 be the change in internal energy in process A and ΔU_2 be the change in internal energy in process B , then

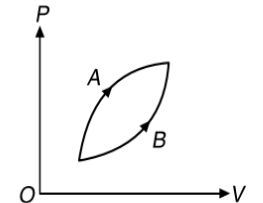

- (A) $Q_1 = Q_2, \Delta U_1 = \Delta U_2$ (B) $Q_1 > Q_2, \Delta U_1 > \Delta U_2$
 (C) $Q_1 < Q_2, \Delta U_1 < \Delta U_2$ (D) $Q_1 > Q_2, \Delta U_1 = \Delta U_2$

36. The end A of rod AB of length 1 m is maintained at 80°C and the end B at 0°C . The temperature at a distance of 60 cm from the end A is

- (A) 16°C (B) 32°C
 (C) 48°C (D) 64°C

37. Three liquids A, B and C are at temperatures of $60^\circ\text{C}, 55^\circ\text{C}$ and 50°C respectively. 4 g of A mixed with 3 g of C gives 55°C and 2 g of A mixed with 3 g of B gives 57°C . The temperature of the mixture when equal masses of B and C are mixed is

- (A) 52.1°C (B) 55°C
 (C) 52.5°C (D) 53°C

38. A closed system receives 200 kJ of heat at constant volume. It then rejects 100 kJ of heat while it has 50 kJ of work done on it at constant pressure. If an adiabatic process can be found which will restore the system to its initial state, the work done by the system during the process is
 (A) 100 kJ (B) 50 kJ
 (C) 150 kJ (D) 200 kJ

39. In a cyclic process shown in the figure an ideal gas is adiabatically taken from B to A, the work done on the gas during the process $B \rightarrow A$ is 30 J, when the gas is taken from A to B the heat absorbed by the gas is 20 J. The change in internal energy of the gas in the process $A \rightarrow B$ is

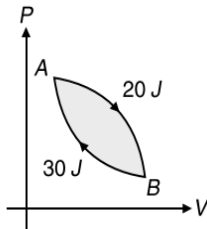

- (A) 20 J (B) -30 J
 (C) 50 J (D) -10 J
40. An air bubble doubles in radius on rising from the bottom of a lake to its surface. Assuming that the bubble rises slowly and the atmospheric pressure to be equal to a column of water of height H , the depth of the lake is
 (A) $4H$ (B) $5H$
 (C) $7H$ (D) $14H$

41. One mole of an ideal diatomic gas is taken through the cycle as shown in Figure. The average molecular speed of the gas in the states 1, 2 and 3 are in the ratio

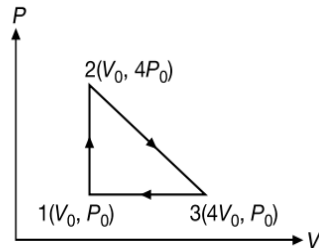

- (A) 1:2:2 (B) $1:\sqrt{2}:\sqrt{2}$
 (C) 1:1:2 (D) 1:2:4
42. A graph is plotted with $\frac{PV}{T}$ on y -axis and mass of the gas along x -axis for different gases. The graph is
 (A) a straight line parallel to x -axis for all the gases
 (B) a straight line passing through origin with a slope having a constant value for all the gases
 (C) a straight line passing through origin with a slope having different values for different gases
 (D) a straight line parallel to y -axis for all the gases
43. Two ends of a conducting rod of varying cross-section are maintained at 200°C and 0°C respectively. In steady state

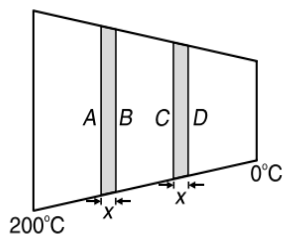

- (A) temperature difference across AB and CD are equal
 (B) temperature difference across AB is greater than that of across CD

- (C) temperature difference across AB is less than that of across CD
 (D) temperature difference may be equal or different depending on the thermal conductivity of the rod

44. The initial state of an ideal gas is represented by the point a on the P - V diagram and its final state by the point e . The gas goes from the state a to the state e by three quasi stationary processes represented by (i) abe , (ii) ace , (iii) ade . The heat absorbed by the gas is

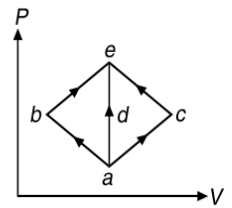

- (A) the same in all the processes.
 (B) the same in processes abe and ace
 (C) less in process abe than in ade
 (D) less in process ace than in ade
45. The efficiency of a heat engine is η and the coefficient of performance of a heat pump is β .
 (A) $\eta = \frac{1}{\beta}$ (B) $\eta\beta = \frac{1}{2}$
 (C) $\eta = \frac{1}{\beta+1}$ (D) $\eta = \frac{1}{\beta-1}$

46. According to the result obtained in PROBLEM 45, the maximum efficiency of a heat engine can be
 (A) 100% (B) 50%
 (C) 25% (D) 12.5%
47. The graphs shows two isotherms for a fixed mass of an ideal gas. The ratio of rms speed of the molecules at temperatures T_1 to that at T_2 is

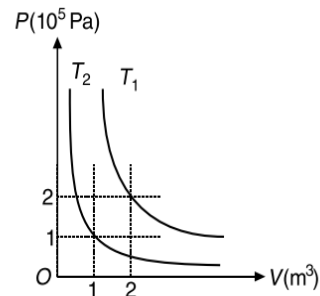

- (A) $2\sqrt{2}$ (B) $\sqrt{2}$
 (C) 2 (D) 4
48. Consider the two insulating sheets with thermal resistances R_1 and R_2 as shown in figure. The temperature θ is

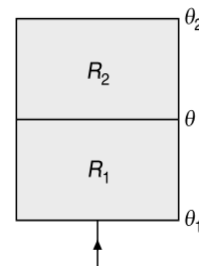

- (A) $\frac{\theta_1\theta_2R_1R_2}{(\theta_1+\theta_2)(R_1+R_2)}$ (B) $\frac{\theta_1R_1+\theta_2R_2}{R_1+R_2}$
 (C) $\frac{(\theta_1+\theta_2)R_1R_2}{R_1^2+R_2^2}$ (D) $\frac{\theta_1R_2+\theta_2R_1}{R_1+R_2}$

2.134 JEE Advanced Physics: Waves and Thermodynamics

49. Two containers of equal volume contain identical gases at pressures P_1 and P_2 and absolute temperatures T_1 and T_2 respectively. The vessels are joined and the gas reaches a common pressure P and a common temperature T . Then

(A) $P = \left(\frac{P_1}{T_1} + \frac{P_2}{T_2} \right) T$ (B) $P = \frac{1}{2} \left(\frac{P_1}{T_1} + \frac{P_2}{T_2} \right) T$
 (C) $P = \left(\frac{P_1 T_2 + P_2 T_1}{T_1^2 + T_2^2} \right) T$ (D) $P = \left(\frac{P_1 T_2 + P_2 T_1}{T_1^2 - T_2^2} \right) T$

50. Two cylinders A and B are taken. The cylinder A is fitted with a moveable piston and cylinder B is fitted with a fixed piston and both contain equal amounts of an ideal monatomic gas at same temperature. If same amount of heat is given to the gas in each cylinder and temperature of the gas in A rises by 15 K, then the rise in temperature of the gas in B is
- (A) 30 K (B) 25 K
 (C) 15 K (D) 20 K

51. Pressure versus density graph of an ideal gas is shown in figure

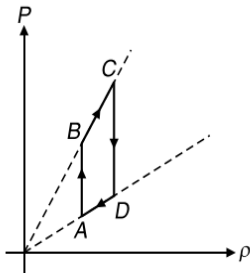

- (A) during the process AB work done by the gas is positive
 (B) during the processes AB work done by the gas is negative
 (C) during the process BC internal energy of the gas is increasing
 (D) None of the above

52. A spherical black body of radius r_0 radiates a power P at temperature T_0 . Another spherical black body of radius $\frac{r_0}{2}$ and at temperature $2T_0$ emits a power
- (A) P (B) $2P$
 (C) $4P$ (D) $8P$

53. A gas undergoes a process in which its pressure P and volume V are related as $PV^n = \text{constant}$, where n is a constant. If $\gamma = \frac{C_P}{C_V}$, then molar heat capacity for the gas in this process is zero for
- (A) $n = \gamma$ (B) $n = \gamma - 1$
 (C) $n = \gamma + 1$ (D) $n = 1 - \gamma$

54. Two different ideal gases are filled in two parts A and B of a container separated by a fixed diathermic (conducting) separator as shown in Figure. The rms speed of the molecules in part A is equal to the mean speed of molecules in the part B . Then ratio of molar mass of gas in part A to that in part B is

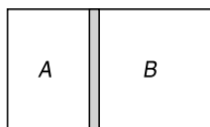

- (A) 1:1 (B) $\pi:2$
 (C) 2:3 (D) $3\pi:8$

55. One mole of an ideal gas with heat capacity C_p at constant pressure undergoes the process $T = T_0 + \alpha V$ where T_0 and α are constants. If its volume increases from V_1 to V_2 , the amount of heat transferred to the gas is

(A) $C_p R T_0 \ln \left(\frac{V_2}{V_1} \right)$
 (B) $\alpha C_p \frac{(V_2 - V_1)}{R T_0} \ln \left(\frac{V_2}{V_1} \right)$
 (C) $\alpha C_p (V_2 - V_1) + R T_0 \ln \left(\frac{V_2}{V_1} \right)$
 (D) $R T_0 \ln \left(\frac{V_2}{V_1} \right) - \alpha C_p (V_1 - V_2)$

56. The P - V diagram shows four different possible reversible processes performed on a monatomic ideal gas. The process B is isothermal and process C is adiabatic. For which process(es) does the temperature of the gas decrease?

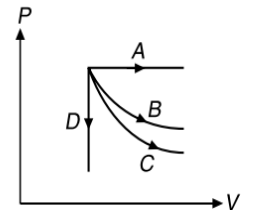

- (A) Process A only
 (B) Process C only
 (C) Only processes C and D
 (D) Only processes A and C

57. If gas molecules undergo inelastic collision with the walls of the container
- (A) the temperature of the gas will decrease
 (B) the pressure of the gas will increase
 (C) neither the temperature nor the pressure will change
 (D) the temperature of the gas will increase

58. n moles of an ideal gas undergo a process in which the temperature changes with volume as $T = KV^2$. The work done by the gas as the temperature changes from T_0 to $4T_0$ is

(A) $3nRT_0$ (B) $\left(\frac{5}{2} \right) nRT_0$
 (C) $\left(\frac{3}{2} \right) nRT_0$ (D) ZERO

59. When a block of iron floats in mercury at 0°C , fraction k_1 of its volume is submerged, while at the temperature 60°C , at fraction k_2 is seen to be submerged. If the coefficient of volume expansion of iron is γ_{Fe} and that of mercury is γ_{Hg} , then the ratio $\frac{k_1}{k_2}$ can be expressed as

(A) $\frac{1 + 60\gamma_{Fe}}{1 + 60\gamma_{Hg}}$ (B) $\frac{1 - 60\gamma_{Fe}}{1 + 60\gamma_{Hg}}$
 (C) $\frac{1 + 60\gamma_{Fe}}{1 - 60\gamma_{Hg}}$ (D) $\frac{1 + 60\gamma_{Hg}}{1 + 60\gamma_{Fe}}$

60. A and B are two points on a uniform metal ring whose centre is O . The angle $AOB = \theta$. A and B are maintained at two different constant temperatures. When $\theta = 180^\circ$, the rate of total heat flow from A to B is 1.2 W. When $\theta = 90^\circ$, this rate will be
- (A) 0.6 W (B) 0.9 W
 (C) 1.6 W (D) 1.8 W

61. Water of volume 2 liter in a container is heated with a coil of 1 kW at 27 °C. The lid of the container is open and energy dissipates at rate of 160 Js⁻¹. The time in which temperature will rise from 27 °C to 77 °C if specific heat of water is given to be 4.2 kJkg⁻¹ is
- (A) 8 min 20 s (B) 6 min 2 s
(C) 7 min (D) 14 min

62. A sample of ideal gas ($\gamma = 1.4$) is heated at constant pressure. If an amount of 100 J heat is supplied to the gas, the work done by the gas is
- (A) 56.28 J (B) 42.12 J
(C) 36.23 J (D) 28.57 J

63. The molar heat capacity of 1 mole of monatomic gas for the process AB shown in Figure is

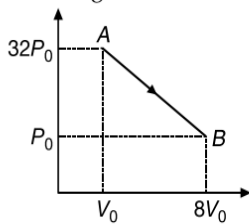

- (A) positive, 3.3R
(B) negative, 3.3R
(C) ZERO
(D) negative,
64. In Ingen Hausz experiment the wax melts up to 5 cm and 10 cm on bars A and B, respectively. The ratio of the thermal conductivities of A and B is
- (A) 1 : 2 (B) 1 : 4
(C) 1 : 8 (D) 1 : 16
65. The work done by 1 mole of Vander Waal's gas, during its isothermal expansion from volume V_1 to V_2 at temperature T is

(A) $RT \ln\left(\frac{V_2}{V_1}\right)$ (B) $RT \ln\left(\frac{V_2 - b}{V_1 - b}\right)$
(C) $a\left(\frac{1}{V_2} - \frac{1}{V_1}\right)$ (D) $RT \ln\left(\frac{V_2 - b}{V_1 - b}\right) + a\left(\frac{1}{V_2} - \frac{1}{V_1}\right)$

(where a and b are Vander Waal's constants)

66. Two spheres of same size are made of the same material but one is solid and the other is hollow. They are heated to the same temperature.
- (A) Both spheres expand equally
(B) The solid sphere expands more
(C) The hollow sphere expands more
(D) Data is insufficient to arrive at a conclusion

67. For an ideal gas, a graph is shown between work done by the gas vs temperature change for three processes. Processes 1, 2 and 3 respectively are

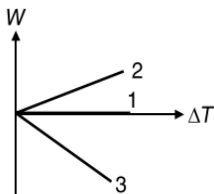

- (A) Isobaric, adiabatic, isochoric
(B) Adiabatic, isobaric, isochoric
(C) Isochoric, adiabatic, isobaric
(D) Isochoric, isobaric, adiabatic

68. In the P - V diagram shown in figure ABC is a semicircle. The work done in the process ABC is
- (A) ZERO
(B) $\frac{\pi}{2}$ atm.lt
(C) $-\frac{\pi}{2}$ atm.lt
(D) 4 atm.lt

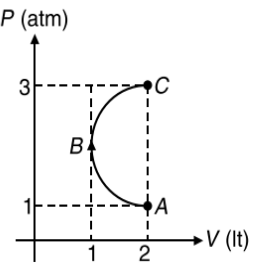

69. P - V diagram of an ideal gas is as shown in figure. Work done by the gas in the process ABCD is
- (A) $4 P_0 V_0$
(B) $2 P_0 V_0$
(C) $3 P_0 V_0$
(D) $P_0 V_0$

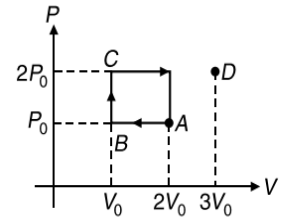

70. Water of volume 2 liter in a container is heated with a coil of 1 kW at 27 °C. The lid of the container is open and energy dissipates at rate of 160 Js⁻¹. The time in which temperature will rise from 27 °C to 77 °C if specific heat of water is given to be 4.2 kJkg⁻¹ is
- (A) 8 min 20 s (B) 6 min 2 s
(C) 7 min (D) 14 min

71. A Carnot engine working between 300 K and 600 K has a work output of 800 J per cycle. The amount of heat energy supplied to the engine from the source per cycle is
- (A) 1200 J (B) 2400 J
(C) 1600 J (D) 3200 J

72. Four spheres A, B, C and D of different metals but of same radius are kept at same temperature. The ratio of their densities and specific heats are 2:3:5:1 and 3:6:2:4. Which sphere will show the fastest rate of cooling (initially)
- (A) A (B) B
(C) C (D) D

73. An engine uses a cyclic process consisting of four different processes. The heat exchange during these processes is $Q_1 = 500$ J, $Q_2 = -100$ J, $Q_3 = 150$ J, $Q_4 = -50$ J. The efficiency of the cycle is
- (A) 77% (B) 63%
(C) 84% (D) 51%

74. Internal energy of n_1 moles of hydrogen at temperature T is equal to the internal energy of n_2 moles of helium at temperature $2T$. Then the ratio $\frac{n_1}{n_2}$ is

(A) $\frac{3}{5}$ (B) $\frac{2}{3}$
(C) $\frac{6}{5}$ (D) $\frac{3}{7}$

75. A cyclic process is shown on the V - T diagram. The same process on a P - T diagram is shown by

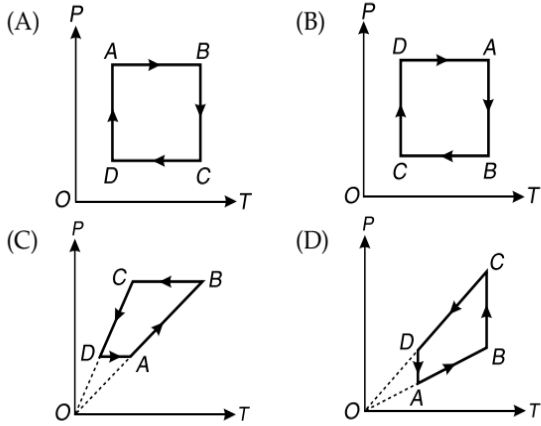
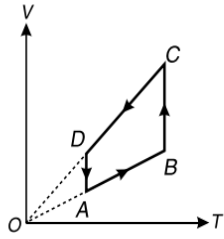

76. The temperature-entropy diagram of a reversible engine cycle is given in the figure. Its efficiency is

- (A) $\frac{1}{3}$
- (B) $\frac{2}{3}$
- (C) $\frac{1}{2}$
- (D) $\frac{1}{4}$

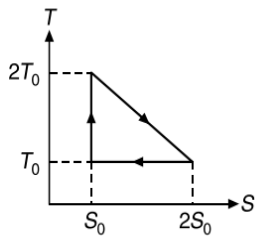

77. The average degrees of freedom per molecule for a gas is 6. The gas performs 25 J of work when it expands at constant pressure. The heat absorbed by gas is

- (A) 75 J
- (B) 100 J
- (C) 150 J
- (D) 125 J

78. The ends of two rods of different materials, having thermal conductivities, radii of cross-section and lengths in the ratio 1 : 2, are maintained at the same temperature difference. If the rate of flow of heat in the larger rod is 4 cal s⁻¹, that in the shorter rod in cal s⁻¹ will be

- (A) 1
- (B) 2
- (C) 8
- (D) 16

79. On a hypothetical scale X, the ice point is 40° and the steam point is 120°. For another scale Y, the ice point and steam point are -30° and 130° respectively. If X reads 50°, then Y would read

- (A) -5°
- (B) -8°
- (C) -10°
- (D) -12°

80. Ideal gas is taken through the process shown in the figure

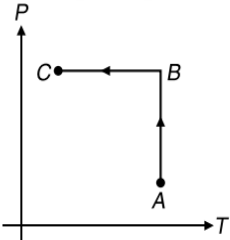

- (A) In process AB, work done by system is positive
- (B) In process AB, heat is rejected
- (C) In process AB, internal energy increases
- (D) In process AB internal energy decrease and in process BC, internal energy increases

81. The pressure and density of a diatomic gas ($\gamma = \frac{7}{5}$) change

adiabatically from (P_1, ρ_1) to (P_2, ρ_2) . If $\left(\frac{\rho_2}{\rho_1}\right) = 32$, then $\left(\frac{P_1}{P_2}\right)$ is

- (A) 128
- (B) $\frac{1}{128}$
- (C) 32
- (D) None of these

82. If pressure and temperature of an ideal gas is doubled and volume is halved, the number of molecules of the gas

- (A) remain constant
- (B) become half
- (C) become two times
- (D) become four times

83. Five rods having thermal conductivities k_1, k_2, k_3, k_4 and k_5 are arranged as shown. The points A and B are maintained at different temperatures such that no thermal current flows through the central rod.

- (A) $k_1 k_4 = k_2 k_3$
- (B) $k_1 = k_3, k_2 = k_4$
- (C) $k_1 k_3 = k_2 k_4$
- (D) $\frac{k_1}{k_4} = \frac{k_3}{k_2}$

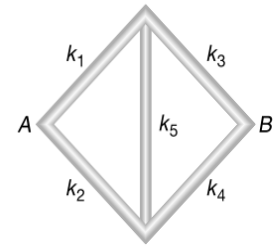

84. A freezer has coefficient of performance 6. If 4×10^6 J of work is done on the freezer, then the mass of water at 0 °C that gets converted into ice cubes at 0 °C is

- (A) ≈ 5 kg
- (B) ≈ 3.6 kg
- (C) ≈ 54 kg
- (D) ≈ 72 kg

85. 120 g of ice at 0 °C is mixed with 100 g of water at 80 °C. Latent heat of fusion is 80 cal g⁻¹ and specific heat of water is 1 cal g⁻¹ °C. The final temperature of the mixture is

- (A) 0 °C
- (B) 40 °C
- (C) 20 °C
- (D) 10 °C

86. In the PROBLEM 85, mass of ice and water in the mixture when thermal equilibrium is attained is

- (A) 40 g ice, 180 g water
- (B) 60 g ice, 160 g water
- (C) 20 g ice, 200 g water
- (D) 10 g ice, 100 g water

87. Temperature of 1 mole of an ideal gas is increased from 300 K to 310 K under isochoric process. Heat supplied to the gas in this process is $Q = 25R$ where $R =$ universal gas constant. What amount of work has to be done by the gas if temperature of the gas decreases from 310 K to 300 K adiabatically

- (A) 10R
- (B) 50R
- (C) 25R
- (D) $\frac{25}{2}R$

88. In the following graph for a given mass of an ideal gas, the ratio of density at B to that at A is

- (A) 5:6
- (B) 3:4
- (C) 6:5
- (D) 4:3

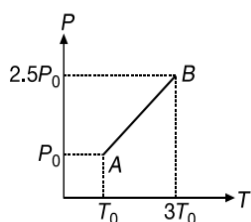

89. A black body radiates power P and maximum energy is radiated by it around a wavelength λ_0 . The temperature of the black body is now changed such that it radiates maximum energy around the wavelength $\frac{3\lambda_0}{4}$. The power radiated by it now is

- (A) $\frac{256}{81}P$
- (B) $\frac{16}{9}P$
- (C) $\frac{64}{27}P$
- (D) $\frac{4}{3}P$

90. A thermodynamic system undergoes cyclic process ABCDA as shown in figure. The work done by the system is

- (A) P_0V_0
- (B) $2P_0V_0$
- (C) $\frac{P_0V_0}{2}$
- (D) ZERO

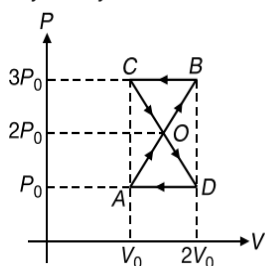

91. Three rods of equal length l are joined to form an equilateral triangle PQR. O is the midpoint of PQ. Distance OR remains same for small change in temperature. Coefficient of linear expansion for PR and RQ is α_2 but that for PQ is α_1 . Then

- (A) $\alpha_2 = 3\alpha_1$
- (B) $\alpha_2 = 4\alpha_1$
- (C) $\alpha_1 = 3\alpha_2$
- (D) $\alpha_1 = 4\alpha_2$

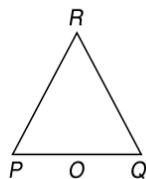

92. Ideal monatomic gas is taken through a process $dQ = 2dU$. The molar heat capacity for the process is (where dQ is heat supplied and dU is change in internal energy)

- (A) $5R$
- (B) $3R$
- (C) R
- (D) None of these

93. A cylindrical metal rod of length L_0 is shaped into a ring with a small gap as shown. On heating the system

- (A) x decreases, r and d increase
- (B) x and r increase, d decreases
- (C) x , r and d all increase
- (D) Data insufficient to arrive at a conclusion

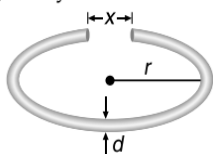

94. A sample of nitrogen gas was taken through the cyclic process shown in Figure. What is the ratio of energy released by the gas in the isochoric process to work done by the gas in the isobaric process?

- (A) 1.5
- (B) 2.5
- (C) 0.4
- (D) 0.66

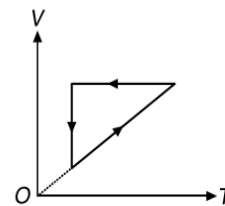

95. A wire of length L_0 is supplied heat to raise its temperature by T . If γ is the coefficient of volume expansion of the wire and Y is the Young's modulus of the wire then the energy density stored in the wire is

- (A) $\frac{1}{2}\gamma^2T^2Y$
- (B) $\frac{1}{3}\gamma^2T^2Y$
- (C) $\frac{1}{18}\frac{\gamma^2T^2}{Y}$
- (D) $\frac{1}{18}\gamma^2T^2Y$

96. Which one of the following would raise the temperature of 20 g of water at 30 °C most when mixed with (Specific heat of water is 1 cal g⁻¹(°C)⁻¹)

- (A) 20 g of water at 40 °C
- (B) 40 g of water at 35 °C
- (C) 10 g of water at 50 °C
- (D) 4 g of water at 80 °C

97. A triangular plate has two cavities, one square and one rectangular as shown. The plate is heated.

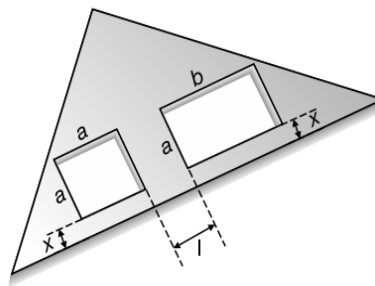

- (A) a increases, b decreases
- (B) a and b both increase
- (C) a and b increase, x and l decrease
- (D) a , b , x and l all increase

98. The three rods described in PROBLEM 276 are placed individually, with their ends kept at the same temperature difference. The rate of heat flow through C is equal to the rate of combined heat flow through A and B. k_C must be equal to

- (A) $k_A + k_B$
- (B) $\frac{k_A k_B}{k_A + k_B}$
- (C) $\frac{1}{2}(k_A + k_B)$
- (D) $2\left(\frac{k_A k_B}{k_A + k_B}\right)$

99. A closed hollow insulated cylinder, filled with gas at 0 °C, is divided into two portions with a movable light insulated piston initially at the middle. The gas on one side of the piston is heated to 100 °C and the piston is seen to move by 5 cm. The length of the cylinder is

- (A) 132 cm
- (B) 87.4 cm
- (C) 38.6 cm
- (D) 64.6 cm

100. Two walls of thickness d_1 and d_2 , thermal conductivities k_1 and k_2 respectively are in contact. If the temperatures at the outer surfaces are T_1 and T_2 respectively, then the temperature at the interface in steady state is

2.138 JEE Advanced Physics: Waves and Thermodynamics

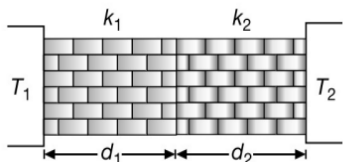

- (A) $\frac{k_1 T_1 + k_2 T_2}{k_1 + k_2}$ (B) $\frac{k_1 T_1 d_2 + k_2 T_2 d_1}{k_1 d_2 + k_2 d_1}$
 (C) $\frac{k_1 T_1 d_1 + k_2 T_2 d_2}{k_1 d_1 + k_2 d_2}$ (D) $\frac{T_1 + T_2}{2}$

101. A gas is expanded to double its volume by two different processes. One is isobaric and the other is isothermal. Let W_1 and W_2 be the respective work done, then

- (A) $W_2 = W_1 \log_e(2)$ (B) $W_2 = \frac{W_1}{\log_e(2)}$
 (C) $W_2 = \frac{W_1}{2}$ (D) data is insufficient

102. A steel tape measures the length of a copper rod as 90 cm when both are at 10 °C, the calibration temperature, for the tape. What would the tape read for the length of the rod when both are at 30 °C. Given $\alpha_{\text{steel}} = 1.2 \times 10^{-5}$ per °C and $\alpha_{\text{Cu}} = 1.7 \times 10^{-5}$ per °C

- (A) 89.00 cm (B) 90.21 cm
 (C) 89.80 cm (D) 90.01 cm

103. Two monatomic ideal gases at absolute temperature T_1 and T_2 are mixed. The masses of the molecules are m_1 and m_2 and the number of molecules in the gases are N_1 and N_2 respectively. The temperature of mixture will be

- (A) $\frac{T_1 + T_2}{2}$ (B) $\frac{N_1 m_1 T_1 + N_2 m_2 T_2}{N_1 m_1 + N_2 m_2}$
 (C) $\frac{N_1 T_1 + N_2 T_2}{N_1 + N_2}$ (D) $\frac{m_1 T_1 + m_2 T_2}{m_1 + m_2}$

104. Six identical conducting rods are joined as shown in figure. Points A and D are maintained at temperatures 200 °C and 20 °C respectively. The temperature of junction B will be

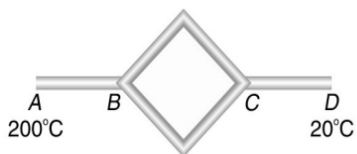

- (A) 120 °C (B) 100 °C
 (C) 140 °C (D) 80 °C

105. A cycle process ABCD is shown in the P-V diagram. Which of the following curves represent the same process?

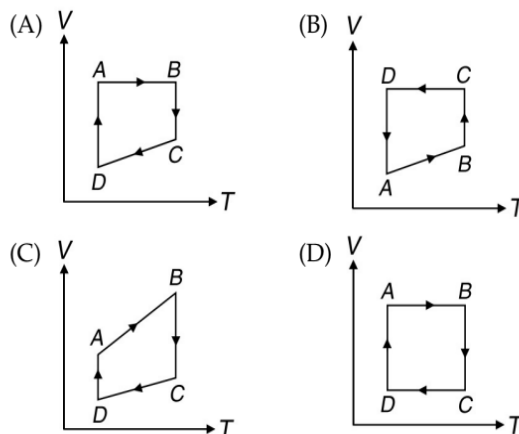
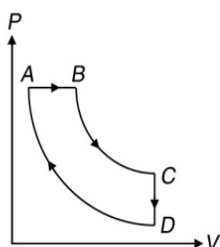

106. An ideal gas follows a process $PT = \text{constant}$. The correct graph between pressure and volume is

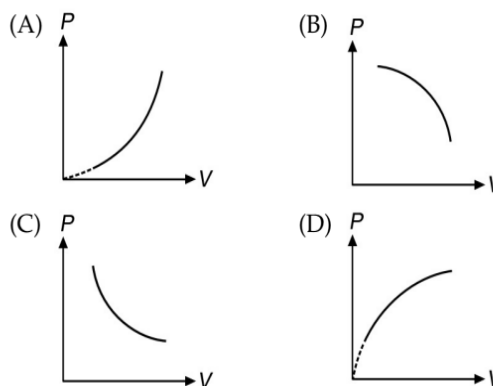

107. A block of steel heated to 100 °C is left in a room to cool. Which of the curves shown in the figure represents the decrease of temperature with time?

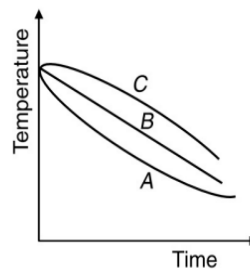

- (A) A (B) B
 (C) C (D) None of these

108. 1 g of water on evaporation at atmospheric pressure forms 1671 cm³ of steam. Heat of vaporisation at this pressure is 540 calg⁻¹. The increase in internal energy is

- (A) 250 cal (B) 500 cal
 (C) 1000 cal (D) 1500 cal

109. A steel rod of length L_0 has a cross-sectional area A. The force required to stretch this rod by the same amount as the expansion produced by heating it through ΔT is (Coefficient of linear expansion of steel is α and Young's Modulus for steel is Y)

- (A) $YA\alpha\Delta T$ (B) $\frac{1}{2}YA\alpha\Delta T$
 (C) $2YA\alpha\Delta T$ (D) None of these

110. The expansion of an ideal gas of mass m at a constant pressure P is given by the straight line D . Then the expansion of the same ideal gas of same mass at a pressure $0.5P$ is given by the straight line

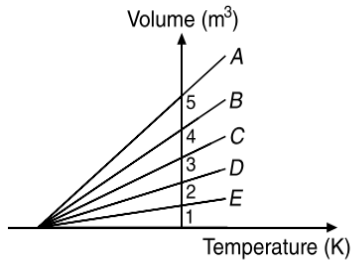

- (A) E (B) C
 (C) B (D) A
111. One end of a conducting rod is maintained at temperature 50°C and at the other end ice is melting at 0°C . The rate of melting of ice is doubled if
- (A) the temperature is made 200°C and the area of cross-section of the rod is doubled
 (B) the temperature is made 100°C and length of the rod is made four times
 (C) area of cross section of rod is halved and length is doubled
 (D) the temperature is made 100°C and area of cross-section of rod and length both are doubled
112. One mole of an ideal monatomic gas is contained in a piston-cylinder arrangement as shown in Figure.

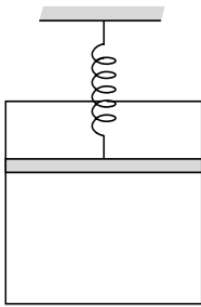

The gas is initially at a pressure of 1 atm and temperature 27°C . The very light piston has cross-sectional area 0.005 m^2 and is connected to an undeformed spring of spring constant 10^4 Nm^{-1} . The work done by the gas when pressure is increased to 3 atm is

- (A) 100 J (B) 50 J
 (C) 150 J (D) 125 J
113. Hot water cools from 60°C to 50°C in the first 10 minutes and to 42°C in the next 10 minutes. The temperature of the surroundings is
- (A) 5°C (B) 10°C
 (C) 15°C (D) 20°C
114. If a body coated black at 600 K surrounded by atmosphere at 300 K has cooling rate r_0 , the same body at 900 K, surrounded by the same atmosphere, will have cooling rate equal to

- (A) $\frac{16}{3}r_0$ (B) $\frac{81}{16}r_0$
 (C) $16r_0$ (D) $4r_0$

115. The figure shows two paths for the change of state of a gas from A to B . The ratio of molar heat capacities in Path 1 and Path 2 is

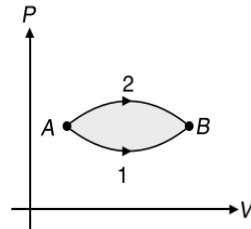

- (A) >1 (B) <1
 (C) 1 (D) Data Insufficient
116. A gas is enclosed in a vessel of volume V at a pressure P . It is being pumped out of the vessel by means of a piston pump with a stroke volume v . Pressure of the gas in the vessel after n strokes is
- (A) $\frac{P}{n}$ (B) $P\left(\frac{v}{V}\right)^n$
 (C) $P\left(\frac{v}{V+v}\right)^n$ (D) $P\left(\frac{V}{V+v}\right)^n$

117. In a cylindrical glass container, a solid silica is placed vertically at its bottom and remaining space is filled with mercury up to the top level of the silica as shown in Figure. Assume that the volume of the silica remains unchanged

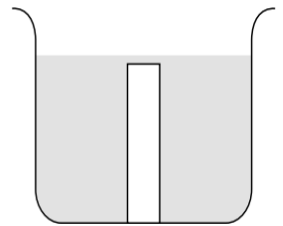

due to variation in temperature. The coefficient of cubical expansion of mercury is γ and coefficient of linear expansion of glass is α . If the top surface of silica and mercury remain at the same level with the variation in temperature, then the ratio of volume of silica to the volume of mercury is equal to

- (A) $\frac{\gamma}{2\alpha}$ (B) $\frac{\gamma}{3\alpha}$
 (C) $\frac{\gamma}{2\alpha} - 1$ (D) $\frac{\gamma}{3\alpha} - 1$
118. A body cools from 50°C to 49.9°C in 5 s. Assuming temperature of surroundings to be 30°C and Newton's law of cooling to be valid, the time it will take to cool from 40°C to 39.9°C is
- (A) 2.5 s (B) 5 s
 (C) 10 s (D) 20 s
119. At room temperature, the rms speed of the molecules of a certain diatomic gas is found to be 1930 ms^{-1} . The gas is
- (A) H_2 (B) F_2
 (C) O_2 (D) Cl_2

2.140 JEE Advanced Physics: Waves and Thermodynamics

120. Two moles of an monatomic gas undergoes a cyclic process as shown in Figure. If the respective temperatures at points a, b, c and d are 400 K, 800 K, 1600 K and 800 K, then the work done per cycle is

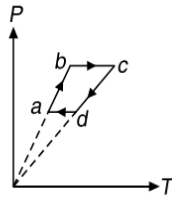

- (A) 3.2 kJ
 (B) 4.8 kJ
 (C) 6.6 kJ
 (D) 8.3 kJ
121. A gas is supplied heat such that its temperature, pressure and volume, all three at any instant change simultaneously such that the work is being done at the expense of the internal energy of the gas. If C be the molar heat capacity of the gas then

- (A) $C = 0$ (B) $C = \frac{dU}{dT}$
 (C) $C = \frac{dW}{dT}$ (D) Data Insufficient

122. Two solid spheres of radii R_1 and R_2 are made of the same material and have similar surfaces. These are raised to the same temperature and then allowed to cool under identical conditions. The ratio of their initial rates of loss of heat are

- (A) $\frac{R_1}{R_2}$ (B) $\frac{R_2}{R_1}$
 (C) $\frac{R_1^2}{R_2^2}$ (D) $\frac{R_2^2}{R_1^2}$

123. In PROBLEM 122, the ratio of the initial rates of cooling (i.e. rates of fall of temperature) is equal to

- (A) $\frac{R_1}{R_2}$ (B) $\frac{R_2}{R_1}$
 (C) $\frac{R_1^2}{R_2^2}$ (D) $\frac{R_2^2}{R_1^2}$

124. One mole of an ideal gas at temperature T was cooled isochorically till the gas pressure fell from P to $\frac{P}{n}$. Then,

by an isobaric process, the gas was restored to the initial temperature. The net amount of heat absorbed by the gas in the process is

- (A) $RT\left(1 - \frac{1}{n}\right)$ (B) $\frac{RT}{n}$
 (C) $RT(n-1)$ (D) nRT

125. The specific heats of an ideal gas at constant pressure and constant volume are $525 \text{ Jkg}^{-1}(\text{°C})^{-1}$ and $315 \text{ Jkg}^{-1}(\text{°C})^{-1}$ respectively. Its density at NTP is

- (A) 0.64 kgm^{-3} (B) 2.62 kgm^{-3}
 (C) 1.20 kgm^{-3} (D) 1.75 kgm^{-3}

126. Two metal rods having same length and area of cross-section are fixed end to end between two rigid supports. The coefficients of linear expansion of the rods are α_1 and α_2 and their respective Young's moduli are Y_1 and Y_2 . The system is now cooled and it is observed that the junction between the rods does not shift at all for the condition.

- (A) $Y_1\alpha_2 = Y_2\alpha_1$ (B) $Y_1\alpha_1^2 = Y_2\alpha_2^2$
 (C) $Y_1\alpha_1 = Y_2\alpha_2$ (D) $Y_1\alpha_2^2 = Y_2\alpha_1^2$

127. Five molecules have speed 2 kms^{-1} , 1.5 kms^{-1} , 1.6 kms^{-1} , 1.6 kms^{-1} and 1.2 kms^{-1} respectively. The most probable speed is

- (A) 2 kms^{-1} (B) 1.58 kms^{-1}
 (C) 1.6 kms^{-1} (D) 1.5 kms^{-1}

128. A steel scale measures the length of a copper rod as L cm when both are at 20 °C , the calibration temperature for the scale. If the coefficients of linear expansion for steel and copper are α_s and α_c respectively, what would be the scale reading (in cm) when both are at 21 °C ?

- (A) $L\left(\frac{1+\alpha_c}{1+\alpha_s}\right)$ (B) $L\frac{\alpha_c}{\alpha_s}$
 (C) $L\frac{\alpha_s}{\alpha_c}$ (D) L

129. Unit mass of a liquid of volume V_1 completely turns into a gas of volume V_2 at constant atmospheric pressure P_0 and temperature T . The latent heat of vaporization is L . Then the change in internal energy of the gas is

- (A) L (B) $L + P(V_2 - V_1)$
 (C) $L - P(V_2 - V_1)$ (D) ZERO

130. How much heat energy should be added to a mixture of 10 g of hydrogen and 40 g of He to change the temperature by 50 °C kept in a closed vessel

- (A) 2500 cal (B) 2750 cal
 (C) 2000 cal (D) None of these

131. A monatomic gas undergoes a process given by $2dU + 3dW = 0$, then the process is

- (A) isobaric (B) adiabatic
 (C) isothermal (D) None of these

132. Molar heat capacity of a monatomic gas during a process obeying $P\sqrt{T} = \text{constant}$ is

- (A) $-3R$ (B) $2.5R$
 (C) $3R$ (D) $2R$

133. The volume thermal expansion coefficient of an ideal gas at constant pressure is (Here T = absolute temperature of gas)

- (A) T (B) T^2
 (C) $\frac{1}{T}$ (D) $\frac{1}{T^2}$

134. An ideal gas mixture filled inside a balloon expands according to the relation $PV^{2/3} = \text{constant}$. The temperature inside the balloon is

- (A) increasing (B) decreasing
 (C) constant (D) Cannot be defined

135. Two rods of copper and brass ($K_C > K_B$) of same length and area of cross-section are joined as shown. End A is kept at 100 °C and end B at 0 °C . The temperature at the junction



- (A) will be more than 50 °C
 (B) will be less than 50 °C
 (C) will be 50 °C
 (D) may be more or less than 50 °C depending upon the size of rods
136. In the following cycle carried out on a diatomic gas, bc is an isothermal process. The gas absorbs 5000 J of heat as its temperature increases from 300 K to 800 K in going from a to b . The quantity of heat rejected by the gas during the process ca is
- (A) 3000 J
 (B) 5000 J
 (C) 7000 J
 (D) 10000 J
-
137. The volume of a block of metal changes by 0.12% when heated through 20 °C. Then α is
- (A) $2 \times 10^{-5} (\text{°C})^{-1}$ (B) $4 \times 10^{-5} (\text{°C})^{-1}$
 (C) $6 \times 10^{-5} (\text{°C})^{-1}$ (D) $8 \times 10^{-5} (\text{°C})^{-1}$
138. A black body at 227 °C radiates heat at the rate of $5 \text{ cal s}^{-1} \text{ cm}^{-2}$. The rate of heat radiated in $\text{cal s}^{-1} \text{ cm}^{-2}$ at 727 °C is
- (A) 40 (B) 80
 (C) 160 (D) 240
139. If the amount of heat given to the system be 35 J and the amount of work done on the system be 15 J, then the change in the internal energy of the system is
- (A) -50 J (B) 20 J
 (C) 30 J (D) 50 J
140. Which one of the following samples of gases has the largest internal energy?
- (A) 1 mole of helium occupying 1 m^3 at 600 K
 (B) 56 g of nitrogen at 10^7 Nm^{-2} and 300 K
 (C) 32 g of oxygen at 1 atm and 300 K
 (D) 12×10^{23} molecules of argon occupying 4 m^3 at 450 K
141. A monatomic ideal gas, initially at temperature T_1 , is enclosed in a cylinder fitted with a frictionless piston. The gas is allowed to expand to a temperature T_2 by releasing the piston suddenly. If L_1 and L_2 be the lengths of the gas column before and after the expansion respectively, then $\frac{T_1}{T_2}$ is given by
- (A) $\left(\frac{L_1}{L_2}\right)^{\frac{2}{3}}$ (B) $\frac{L_1}{L_2}$
 (C) $\frac{L_2}{L_1}$ (D) $\left(\frac{L_2}{L_1}\right)^{\frac{2}{3}}$

142. The quantity $\frac{PV}{kT}$ (k = Boltzmann's constant) represents
- (A) number of moles of the gas
 (B) total mass of the gas
 (C) number of molecules in the gas
 (D) density of the gas
143. Volume versus temperature graph of two moles of helium gas is as shown in figure. The ratio of heat absorbed and the work done by the gas in process 1-2 is
- (A) 3
 (B) $\frac{5}{2}$
 (C) $\frac{5}{3}$
 (D) $\frac{7}{2}$
-
144. A wall has two layers A and B , each made of different material. Both the layers have the same thickness. The thermal conductivity of the material of A is twice that of B . Under thermal equilibrium the temperature difference across the wall is 36 °C. The temperature difference across the layer A is
- (A) 6 °C (B) 12 °C
 (C) 18 °C (D) 24 °C
145. A metal ball immersed in water weighs W_1 at 0 °C and W_2 at 50 °C. The coefficient of cubical expansion of metal is less than that of water. Then
- (A) $W_1 > W_2$ (B) $W_1 < W_2$
 (C) $W_1 = W_2$ (D) data is insufficient
146. A linear accelerator consists of a hundred brass discs tightly fitted into a steel tube. At 40 °C the diameter of each disc is 10.02 cm. The system is assembled by cooling the discs in dry ice at -60 °C to enable them to slide into the close fitting tube. If the coefficient of expansion of brass is $2 \times 10^{-5} \text{ °C}^{-1}$, the diameter of each disc in dry ice will be
- (A) 9.94 cm (B) 9.96 cm
 (C) 9.98 cm (D) 10.00 cm
147. A system is taken from state A to state B along two different paths 1 and 2. The work done on the system along these two paths is W_1 and W_2 respectively. The heat absorbed by the system along these two paths is Q_1 and Q_2 respectively. The internal energy at A and B is U_A and U_B respectively
- (A) $W_1 = W_2 = U_B - U_A$
 (B) $Q_1 = Q_2 = U_A - U_B$
 (C) $Q_1 + W_1 = Q_2 + W_2 = U_A + U_B$
 (D) $Q_1 + W_2 = Q_2 + W_1 = U_B - U_A$
148. Two pistons can move freely inside a horizontal cylinder having two sections of unequal cross-sections. The pistons are joined by an inextensible, light string and same gas is enclosed between the pistons. On cooling the system, the pistons will
-

2.142 JEE Advanced Physics: Waves and Thermodynamics

- (A) move to the left
 (B) move to the right
 (C) remain stationary
 (D) follow (A) or (C) depending upon the initial pressure of the gas

149. A given sample of gas can be taken from state A to state B by two different processes shown in Figure. Heat added to the system will be

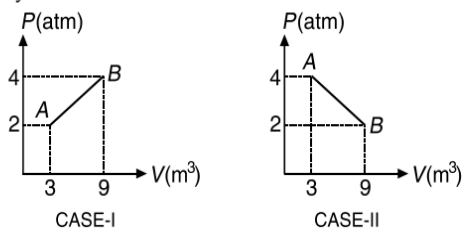

- (A) more in CASE-1
 (B) more in CASE-2
 (C) same in both cases and non-zero
 (D) zero in both cases

150. A gas undergoes a change of state during which 100 J of heat is supplied to it and it does 20 J of work. The system is brought back to its original state through a process during which 20 J of heat is released by the gas. The work done by the gas in the second process is

- (A) 60 J
 (B) 40 J
 (C) 80 J
 (D) 20 J

151. Two rods of length L_2 and coefficient of linear expansion α_2 are connected freely to a third rod of length L_1 of coefficient of linear expansion α_1 to form an isosceles triangle. The arrangement is supported on the knife edge at the midpoint of L_1 which is horizontal. The apex of the isosceles triangle is to remain at a constant distance from the knife edge if

- (A) $\frac{L_1}{L_2} = \frac{\alpha_2}{\alpha_1}$ (B) $\frac{L_1}{L_2} = \sqrt{\frac{\alpha_2}{\alpha_1}}$
 (C) $\frac{L_1}{L_2} = 2\frac{\alpha_2}{\alpha_1}$ (D) $\frac{L_1}{L_2} = 2\sqrt{\frac{\alpha_2}{\alpha_1}}$

152. 1 g of ice at 0°C is mixed with 1 g of steam at 100°C . After thermal equilibrium is attained the temperature of the mixture is

- (A) 1°C (B) 50°C
 (C) 81°C (D) 100°C

153. In PROBLEM 152, the maximum mass of ice that can be taken to get the equilibrium temperature (as calculate above) is

- (A) 1 g (B) 2 g
 (C) 3 g (D) 4 g

154. Which statements is true (T) or false (F)

- (i) A refrigerator is reverse of a heat engine.
 (ii) A heat pump is the same as a refrigerator.
 (iii) The coefficient of performance of a refrigerator can be infinite.
 (iv) In a heat engine, heat cannot be fully converted to work.

- (A) i-F, ii-F, iii-F, iv-T (B) i-T, ii-T, iii-F, iv-T
 (C) i-T, ii-F, iii-T, iv-T (D) i-F, ii-T, iii-F, iv-F

155. In a 10 metre deep lake, the bottom is at a constant temperature of 4°C . The air temperature is constant at -4°C . The thermal conductivity of ice is 3 times that of water. Neglecting the expansion of water on freezing, the maximum thickness of ice will be

- (A) 7.5 m (B) 6 m
 (C) 5 m (D) 2.5 m

156. Liquid oxygen at 50 K is heated to 300 K at constant pressure of 1 atm. The rate of heating is constant. Which of the following graphs represents the variation of temperature with time?

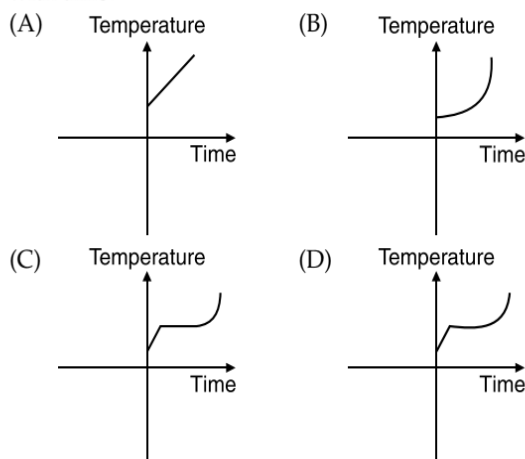

157. An ideal monatomic gas undergoes a process AB as shown in Figure.

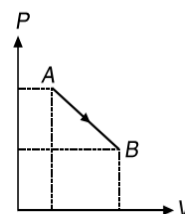

If $P_A = 2P_B = 10^6 \text{ Nm}^{-2}$ and $V_B = 4V_A = 0.4 \text{ m}^3$, then the heat absorbed by the gas in this process is

- (A) 350 kJ (B) 375 kJ
 (C) 425 kJ (D) 500 kJ

158. During adiabatic process pressure (P) versus density (ρ) equation is

- (A) $P\rho^\gamma = \text{constant}$ (B) $P\rho^{-\gamma} = \text{constant}$
 (C) $P^\gamma\rho^{1+\gamma} = \text{constant}$ (D) $P^\frac{1}{\gamma}\rho^\gamma = \text{constant}$

159. A cylindrical tube of uniform cross-sectional area A is fitted with two air tight frictionless pistons. The pistons are connected to each other by a metallic wire. Initially the pressure of the gas is P_0 and temperature is T_0 . Atmospheric pressure is also P_0 . Now the temperature of the gas is increased to $2T_0$, the tension in the wire will be

- (A) $2P_0A$
 (B) P_0A
 (C) $P_0A/2$
 (D) $4P_0A$

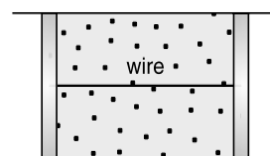

160. Three moles of an ideal monatomic gas performs a cycle $1 \rightarrow 2 \rightarrow 3 \rightarrow 4 \rightarrow 1$ as shown. The gas temperature in different states are $T_1 = 400\text{ K}$, $T_2 = 800\text{ K}$, $T_3 = 2400\text{ K}$ and $T_4 = 1200\text{ K}$. The work done by the gas during the cycle is

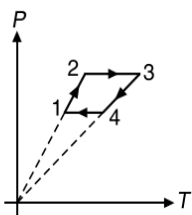

- (A) $1200R$ (B) $3600R$
 (C) $2400R$ (D) $2000R$
161. In the given Figure isothermal graphs for an ideal gas
- (A) $T_A > T_B$
 (B) $T_B > T_A$
 (C) $T_A = T_B$
 (D) $T_A \geq T_B$

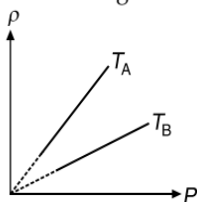

162. If 2 moles of an ideal monatomic gas at temperature T_0 is mixed with 4 moles of another ideal monatomic gas at temperature $2T_0$, then the temperature of the mixture is
- (A) $\frac{5}{3}T_0$ (B) $\frac{3}{2}T_0$
 (C) $\frac{4}{3}T_0$ (D) $\frac{5}{4}T_0$
163. An aluminium measuring rod, which is correct at 5°C measures the length of a line as 80 cm at 45°C . If thermal coefficient of linear expansion of aluminium is 2.50×10^{-5} per $^\circ\text{C}$. The correct length of the line is
- (A) 80.08 cm (B) 79.92 cm
 (C) 81.12 cm (D) 79.62 cm

164. Two rods of the same material have diameters in the ratio $1:2$ and length in the ratio $2:1$. If the temperature difference between their ends is the same, the ratio of the heats conducted by them in a given time is
- (A) $1:4$ (B) $4:1$
 (C) $1:8$ (D) $8:1$

165. A polished metal plate with a rough black spot on it is heated to about 1400 K and quickly taken to dark room. Then the spot
- (A) will appear brighter than the plate
 (B) will appear darker than the plate
 (C) and the plate will appear equally bright
 (D) the plate will not be visible in dark room

166. A stationary vertical cylindrical container of very large height filled with a gas of molar mass M at constant Temperature. The pressure at the bottom is P_1 and at the top is P_2 . If the acceleration due to gravity is assumed to be constant for the whole cylinder, which is equal to g . Then the height of the cylinder is

- (A) $\frac{RT}{Mg} \ln \frac{P_1}{P_2}$ (B) $\frac{RT}{2Mg} \ln \frac{P_1}{P_2}$
 (C) $\frac{2RT}{Mg} \ln \frac{P_1}{P_2}$ (D) $\frac{RT}{3Mg} \ln \frac{P_1}{P_2}$

167. Two identical rods of the same material are joined in series. Under a temperature difference, a certain quantity of heat flows through the combination in four minutes. If the two rods are joined in parallel, the same quantity of heat will flow through the combination under the same temperature difference in
- (A) 1 min (B) 2 min
 (C) 8 min (D) 16 min

168. The molar heat capacity in a process of a diatomic gas if it does a work of $\frac{Q}{4}$ when a heat of Q is supplied to it is
- (A) $\frac{2}{5}R$ (B) $\frac{5}{2}R$
 (C) $\frac{10}{3}R$ (D) $\frac{6}{7}R$

169. Two air tight frictionless pistons connected to each other by a metallic wire are fitted in a uniform cylindrical vessel of cross-sectional area 1 m^2 as shown in Figure.

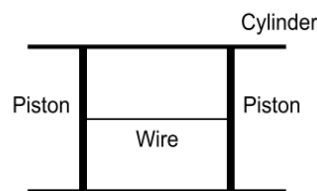

Initially the vessel contains an ideal gas at atmospheric pressure P_0 at temperature 27°C . If the temperature of the gas is doubled on absolute scale, the tension in the wire will be about

- (A) 1 N (B) 10^5 N
 (C) $2 \times 10^5\text{ N}$ (D) zero
170. The coefficient of linear expansion for a certain metal varies with temperature as $\alpha(T)$. If L_0 is the initial length of the metal and the temperature of metal is changed from T_0 to $T (< T_0)$. Then,

- (A) $L = L_0 \int_{T_0}^T \alpha(T) dT$ (B) $L = L_0 \left[1 - \int_T^{T_0} \alpha(T) dT \right]$
 (C) $L = L_0 \left[1 - \int_{T_0}^T \alpha(T) dT \right]$ (D) $L > L_0$

171. Water in a lake is changing into ice at 0°C when the atmospheric temperature is 10°C . If the time taken for 1 cm thick ice layer to be formed is 7 hour, the time required for the thickness of ice to increase from 1 cm to 2 cm is
- (A) 7 hour (B) 14 hour
 (C) < 7 hour (D) > 14 hour

2.144 JEE Advanced Physics: Waves and Thermodynamics

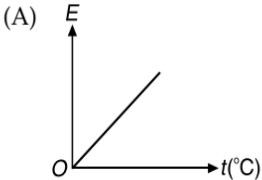
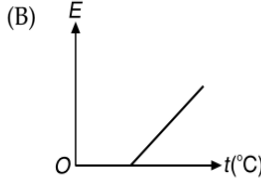
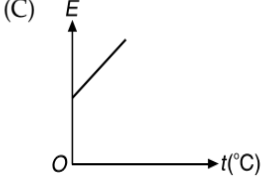
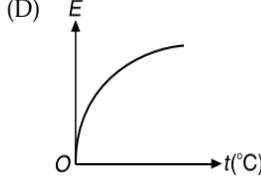
172. Four rods of same material but different radii r and lengths l are used to connect two reservoirs of heat at different temperatures. The one which will conduct most heat is
 (A) $r = 2 \text{ cm}, l = 0.5 \text{ m}$ (B) $r = 2 \text{ cm}, l = 2 \text{ m}$
 (C) $r = 1 \text{ cm}, l = 1 \text{ m}$ (D) $r = 0.5 \text{ cm}, l = 0.5 \text{ cm}$
173. Two slabs A and B having lengths l_1 and l_2 , respectively, and having same cross-section have thermal conductivities K_1 and K_2 respectively. They are placed in contact and constant temperature difference is maintained across the combination. The ratio of the quantities of heat flowing through A and B in a given time is
 (A) $\frac{K_1}{l_1} : \frac{K_2}{l_2}$ (B) $\frac{K_1}{l_2} : \frac{K_2}{l_1}$
 (C) $K_1 l_1 : K_2 l_2$ (D) 1:1
174. If the ratio of number of moles of hydrogen gas to oxygen gas is two, the ratio of total translational kinetic energy of hydrogen gas molecules to that of oxygen molecules at 20°C is
 (A) 1:1 (B) 2:1
 (C) 1:8 (D) 1:16
175. The temperature of a room heated by a heater is 20°C when outside temperature is -20°C and it is 10°C when the outside temperature is -40°C . The temperature of the heater is
 (A) 80°C (B) 100°C
 (C) 40°C (D) 60°C
176. The loss in weight of a solid when immersed in a liquid at 0°C is W_0 and at $t^\circ\text{C}$ is W . If the coefficients of volume expansion of the solid and the liquid be γ_s and γ_l respectively, then
 (A) $W = W_0[(\gamma_s - \gamma_l)t]$ (B) $W = W_0[1 + (\gamma_s - \gamma_l)t]$
 (C) $W = \frac{W_0 t}{\gamma_l - \gamma_s}$ (D) $W = W_0[1 - (\gamma_s - \gamma_l)t]$
177. The temperatures of the source and the sink in Carnot engine are 400 K and 300 K respectively. If the engine receives 600 cal of heat from the source per cycle, the heat rejected to the sink per cycle is
 (A) 150 cal (B) 300 cal
 (C) 400 cal (D) 450 cal
178. The absolute temperature T of a gas is plotted against its pressure P for two different constant volumes V_1 and V_2 where $V_1 > V_2$. T is plotted along x -axis and P along y -axis.
 (A) Slope for curve corresponding to volume V_1 is greater than that corresponding to volume V_2
 (B) Slope for curve corresponding to volume V_2 is greater than that corresponding to volume V_1
 (C) Slope for both curves are equal
 (D) Slope for both curves are unequal such that they intersect at $T = 0$
179. An ideal heat engine having 40% efficiency is operating with a heat sink at 47°C . The temperature of heat source is
 (A) 260°C (B) 78°C
 (C) 527°C (D) 117°C
180. Two spherical black bodies of radii r_1 and r_2 and with surface temperatures T_1 and T_2 respectively radiate the same power. $\frac{r_1}{r_2}$ must be equal to
 (A) $\left(\frac{T_1}{T_2}\right)^2$ (B) $\left(\frac{T_2}{T_1}\right)^2$
 (C) $\left(\frac{T_1}{T_2}\right)^4$ (D) $\left(\frac{T_2}{T_1}\right)^4$
181. The ratio of specific heat of a gas at constant pressure to that at constant volume is γ . The change in internal energy of a mass of gas when the volume changes from V to $2V$ at constant pressure P is
 (A) $\frac{R}{\gamma - 1}$ (B) PV
 (C) $\frac{PV}{\gamma - 1}$ (D) $\frac{\gamma PV}{\gamma - 1}$
182. The graph which represent the variation of mean kinetic energy of molecules with temperature t (in celsius) is
 (A)  (B) 
 (C)  (D) 
183. When a copper sphere is heated percentage change
 (A) is maximum in radius
 (B) is maximum in volume
 (C) is maximum in density
 (D) is equal in radius, volume and density
184. 70 calories of heat is required to raise the temperature of 2 moles of an ideal gas at constant pressure from 40°C to 45°C ($R = 2 \text{ cal mol}^{-1} (\text{°C})^{-1}$). The gas may be
 (A) H_2 (B) He
 (C) CO_2 (D) NH_3
185. A rod of length 20 cm made of a metal A expands by 0.075 cm when its temperature is raised from 0°C to 100°C . Another rod of a different metal B having the same length expands by 0.045 cm for the same change in temperature. A third rod of the same length is composed of two parts, one of metal A and the other of metal B . This rod expands by 0.060 cm for the same change in temperature. The portion made of metal A has length
 (A) 20 cm (B) 10 cm
 (C) 15 cm (D) 18 cm
186. A body cools from 50°C to 49.9°C in 5 s. How long will it take to cool from 40°C to 39.9°C ? Assume temperature of surroundings to be 30°C and Newton's Law of Cooling is valid

- (A) 2.5 s (B) 10 s
(C) 20 s (D) 5 s

187. The area of the cross section of the steel rod is twice that of the copper rod in the above Figure. What is approximate temperature of the steel-copper junction in the steady state of system? Thermal conductivity of steel = $50.2 \text{ Js}^{-1}\text{mK}$
Thermal conductivity of copper = $385 \text{ Js}^{-1}\text{mK}$

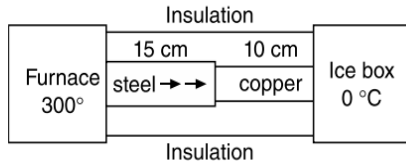

- (A) 44 °C (B) 33 °C
(C) 120 °C (D) 84 °C

188. 3.2 kg of ice at -10°C just melts with a mass m of steam
(A) $m = 400 \text{ g}$ (B) $m = 800 \text{ g}$
(C) $m = 425 \text{ g}$ (D) $m = 900 \text{ g}$

189. A planet having average surface temperature T_0 is at an average distance d from the sun. Assuming that the planet receives radiant energy from the sun only and it loses radiant energy only from its surface and neglecting all other atmospheric effects we conclude
(A) $T_0 \propto d^2$ (B) $T_0 \propto d^{-2}$
(C) $T_0 \propto d^{\frac{1}{2}}$ (D) $T_0 \propto d^{-\frac{1}{2}}$

190. One mole of a gas expands according to the relation $V = kT^{2/3}$. The work done to increase the temperature of gas by 30°C is
(A) $10R$ (B) $20R$
(C) $40R$ (D) $60R$

191. A gas has volume V and pressure p . The total translational kinetic energy of all the molecules of the gas is
(A) $\frac{3}{2}pV$ only if the gas is monatomic
(B) $\frac{3}{2}pV$ only if the gas is diatomic
(C) $> \frac{3}{2}pV$ if the gas is diatomic
(D) $\frac{3}{2}pV$ in all cases

192. An electrical steam generator has rated power 1000 W and heat converting efficiency is 0.9. Water enters the inlet at 20°C and steam comes out from the outlet at 100°C . Latent heat of steam is 2250 Jg^{-1} . The mass of water entering the device per second is
(A) 1.5 g (B) 0.5 g
(C) 0.35 g (D) 0.39 g

193. Change in internal energy of an ideal gas is given by $\Delta U = nC_V\Delta T$. This is applicable for (C_V = molar heat capacity at constant volume)

- (A) isochoric process only
(B) all processes
(C) a process where ΔT is positive
(D) all the processes except isothermal process

194. A gas expands in a piston cylinder device from V_1 to V_2 , the process being described by $P = \frac{a}{V} + b$ where P is in Nm^{-2} and V is in cubic metre. The work done in the process is

- (A) $a \log_e \left(\frac{V_1}{V_2} \right) + b(V_2 - V_1)$
(B) $-a \log_e \left(\frac{V_2}{V_1} \right) - b(V_2 - V_1)$
(C) $-a \log_e \left(\frac{V_1}{V_2} \right) - b(V_2 - V_1)$
(D) $a \log_e \left(\frac{V_2}{V_1} \right) + b(V_2 - V_1)$

195. A sample of an ideal gas is in a cylinder fitted with a piston. As 5.76 kJ of heat is supplied to the gas to raise its temperature, the pressure the gas adjusted so that the state of the gas changes from point A to point B along the semicircle in P - V graph shown in Figure. The change in internal energy of the gas is
(A) 3.2 kJ (B) 1.6 kJ
(C) 6.4 kJ (D) 4.2 kJ

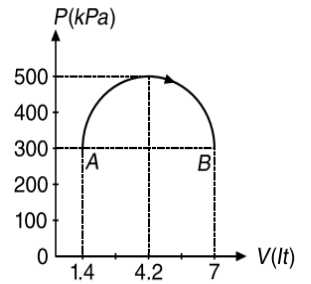

196. The root mean square (rms) speed of hydrogen molecules at a certain temperature is 300 ms^{-1} . If the temperature is doubled and hydrogen gas dissociates into atomic hydrogen the r.m.s. speed will become
(A) 424.26 ms^{-1} (B) 300 ms^{-1}
(C) 600 ms^{-1} (D) 50 ms^{-1}

197. A black body is at a temperature of 2880 K. The energy of radiation emitted by this object with wavelength between 499 nm and 500 nm is U_1 , between 999 nm and 1000 nm is U_2 and between 1499 nm and 1500 nm is U_3 . The Wein constant, $b = 2.88 \times 10^6 \text{ nm}\cdot\text{K}$. Then
(A) $U_1 = 0$ (B) $U_3 = 0$
(C) $U_1 > U_2$ (D) $U_2 > U_1$

198. Three rods A, B and C of same length and cross-sectional area are joined in series. Their thermal conductivities are in the ratio 1 : 2 : 1.5. If the open ends of A and C are at 200°C and 18°C , respectively. At equilibrium, the temperature at the junction of A and B is
(A) 74°C (B) 116°C
(C) 156°C (D) 148°C

199. A gas has a molar specific heat C_V at constant volume. n moles of this gas is heated such that rise in temperature is ΔT . The internal energy changes by an amount $nC_V\Delta T$

2.146 JEE Advanced Physics: Waves and Thermodynamics

- (A) only if ΔT occurs at constant pressure.
- (B) only if ΔT occurs at constant volume.
- (C) in any non-adiabatic process.
- (D) in any known process.

200. Three samples of the same gas A , B , and C ($\gamma = \frac{3}{2}$) have initially equal volume. Now the volume of each sample is doubled. The process is adiabatic for A isobaric for B and isothermal for C . If the final pressures are equal for all three samples, the ratio of their initial pressures are

- (A) $2\sqrt{2} : 2 : 1$
- (B) $2\sqrt{2} : 1 : 2$
- (C) $\sqrt{2} : 1 : 2$
- (D) $2 : 1 : \sqrt{2}$

201. Two hollow spheres A and B of different materials are filled with ice and kept in the same room. Ratio of thermal conductivity of A to that of B is $1 : 2$. If time taken for complete melting of ice in sphere A is 80 min, then time taken by ice in sphere B to melt completely is

- (A) 30 minutes
- (B) 60 minutes
- (C) 80 minutes
- (D) 160 minutes

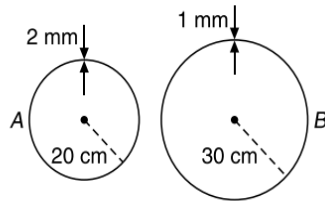

202. The mass of 1 litre of He under a pressure of 2 atmosphere and a temperature of $27^\circ C$ is

- (A) 0.16 g
- (B) 0.32 g
- (C) 0.48 g
- (D) 0.64 g

203. If two rods of length L and $2L$ having coefficients of linear expansion α and 2α respectively are connected so that total length becomes $3L$, the average coefficient of linear expansion of the composite rod equals

- (A) $\frac{3}{2}\alpha$
- (B) $\frac{5}{2}\alpha$
- (C) $\frac{5}{3}\alpha$
- (D) None of these

204. 8 g of steam condenses when passed through 80 g of water initially at $10^\circ C$. If the temperature of water rises to $60^\circ C$, latent heat of steam is

- (A) 460 cal g^{-1}
- (B) 540 cal g^{-1}
- (C) 240 cal g^{-1}
- (D) 500 cal g^{-1}

205. A cyclic process is shown on the p - T diagram. Which of the curves show the same process on a p - V diagram?

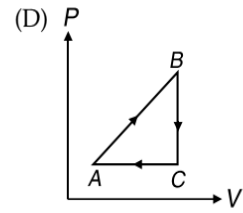
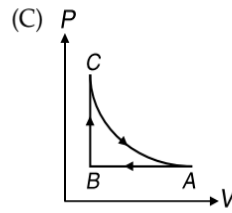
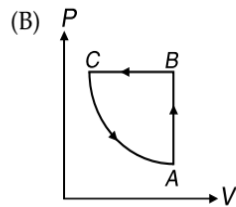
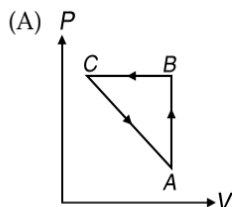
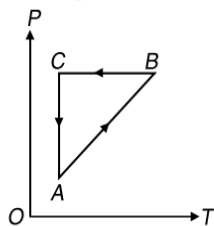

206. The intensity of radiation emitted by the Sun has its maximum value at a wavelength of 510 nm and that emitted by the North Star has the maximum value at 350 nm. If these stars behave like black bodies, then the ratio of the surface temperatures of the Sun and the North Star is

- (A) 1.46
- (B) 0.69
- (C) 1.21
- (D) 0.83

207. A monatomic gas expands at constant pressure on heating. The percentage of heat supplied that increases the internal energy of the gas and that is involved in the expansion is

- (A) 75%, 25%
- (B) 25%, 75%
- (C) 60%, 40%
- (D) 40%, 60%

208. A gas mixture contains N molecules each of mass m of gas A and $2N$ molecules each of mass $3m$ of gas B . If the rms speed of molecules of gas B is V and the mean square of x component of the velocity of molecules of gas A is v^2 , then $\frac{v^2}{V^2}$ equals

- (A) 4
- (B) 3
- (C) 2
- (D) 1

209. Temperature of an ideal gas is 300 K. The change in temperature of the gas when its volume changes from V to $2V$ in the process $P = aV$ (Here a is a positive constant) is

- (A) 900 K
- (B) 1200 K
- (C) 600 K
- (D) 300 K

210. 20 g of ice at $-10^\circ C$ is dropped into a calorimeter containing 20 g of water at $20^\circ C$. Given that the specific heat of water is twice that of ice, at equilibrium, the calorimeter has

- (A) 16.25 g of ice and 23.75 g of water
- (B) 12.5 g of ice and 27.5 g of water
- (C) 20 g of ice and 20 g of water
- (D) 40 g of water

211. The temperature of source and sink of a Carnot Engine are $327^\circ C$ and $27^\circ C$, respectively. The efficiency of the engine is

- (A) $1 - \left(\frac{27}{327}\right)$
- (B) $\frac{27}{327}$
- (C) 0.5
- (D) 0.7

212. Three rods A , B and C have the same dimensions. Their thermal conductivities are k_A , k_B , and k_C respectively. A and B are placed end to end, with their free ends kept at certain temperature difference. C is placed separately with its ends kept at same temperature difference. The two arrangements conduct heat at the same rate. k_C must be equal to

- (A) $k_A + k_B$ (B) $\frac{k_A k_B}{k_A + k_B}$
 (C) $\frac{1}{2}(k_A + k_B)$ (D) $\frac{2k_A k_B}{k_A + k_B}$

213. An ideal gas at pressure P and volume V is expanded to volume $2V$. **COLUMN-I** represents the thermodynamic process used during expansion. **COLUMN-II** represents the work during these process in the random order

COLUMN-I	COLUMN-II
i. Isobaric	p. $\frac{PV(1-2^{1-\gamma})}{\gamma-1}$
ii. Isothermal	q. PV
iii. Adiabatic	r. $PV \ln 2$

- (A) i-r, ii-q, iii-p (B) i-q, ii-p, iii-r
 (C) i-q, ii-r, iii-p (D) i-p, ii-q, iii-r
214. The least amount of work that must be done to freeze one gram of water at 0°C by means of a refrigerator placed in surrounding at 27°C is
 (A) 7.9 cal (B) 11.9 cal
 (C) 13.9 cal (D) 15.9 cal
215. Certain amount of an ideal gas are contained in a closed vessel. The vessel is moving with a constant velocity v . The molecular mass of gas is M . The rise in temperature of the gas when the vessel is suddenly stopped is $\left(\gamma = \frac{C_p}{C_v}\right)$
 (A) $\frac{Mv^2}{2R(\gamma+1)}$ (B) $\frac{Mv^2(\gamma-1)}{2R}$
 (C) $\frac{Mv^2}{2R\gamma}$ (D) $\frac{Mv^2\gamma}{2R(\gamma-1)}$
216. According to Debye's T^3 Law, the specific heat of many solids at low temperature T varies according to the relation $c = \alpha T^3$, where α is a constant. The heat energy required to raise the temperature of 4 kg mass from $T = 1\text{ K}$ to $T = 3\text{ K}$ is
 (A) 208α (B) 20α
 (C) 80α (D) 8α
217. The relation between U , p and V for a gas in an adiabatic process is given by relation $U = a + bPV$. Find the value of adiabatic exponent (γ) of this gas
 (A) $\frac{b+1}{b}$ (B) $\frac{b+1}{a}$
 (C) $\frac{a+1}{b}$ (D) $\frac{a}{a+b}$
218. Earth receives 1400 Wm^{-2} of solar power. If all the solar energy falling on a lens of area 0.2 m^2 is focussed on to a block of ice of mass 280 g , the time taken to melt the ice will be (Take latent heat of fusion of ice is $3.3 \times 10^5\text{ Jkg}^{-1}$)

- (A) 303 s (B) 330 s
 (C) 33 s (D) 5.5 s

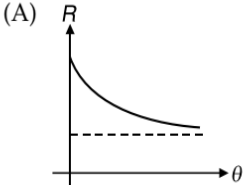
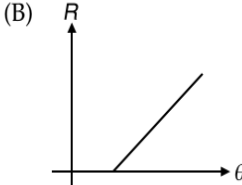
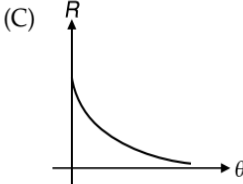
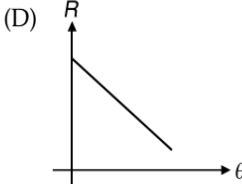
219. The ratio $\frac{C_p}{C_v} = \gamma$ for a gas. Its molecular weight is M . Its specific heat capacity at constant pressure is
 (A) $\frac{R}{\gamma-1}$ (B) $\frac{\gamma R}{\gamma-1}$
 (C) $\frac{\gamma R}{M(\gamma-1)}$ (D) $\frac{\gamma RM}{(\gamma-1)}$
220. Let 1 litre of a gas at 127°C be cooled to 27°C at constant pressure. Change in its volume will be
 (A) 750 ml (B) -750 ml
 (C) 250 ml (D) -250 ml
221. Two container having the same volume contain different gases at the same temperature but one exerting twice the pressure exerted by the other. The ratio of the number of molecules in two gases is
 (A) 1:2 (B) 2:1
 (C) $\sqrt{2}:1$ (D) $1:\sqrt{2}$
222. A Carnot engine takes 300 cal of heat at 500 K and rejects 150 cal of heat to the sink. The temperature of the sink is
 (A) 1000 K (B) 750 K
 (C) 250 K (D) 125 K
223. Heat can enter a thermos-flask only through a cork fitted in its opening. Cork has an area 100 cm^2 and thickness 4 cm. Its thermal conductivity is $0.008\text{ cal s}^{-1}\text{ cm}^{-1}\text{ }^\circ\text{C}^{-1}$. If the outside temperature is 30°C , time taken by 200 g of ice to melt is about
 (A) 45 minutes (B) 55 minutes
 (C) 30 minutes (D) 35 minutes
224. Temperature of a body θ is slightly more than the temperature of the surrounding θ_0 . Its rate of cooling (R) versus temperature of body (θ) is plotted, its shape would be
 (A)  (B) 
 (C)  (D) 
225. Helium gas goes through a cycle ABCDA as shown in Figure. Efficiency of this cycle is nearly
 (A) 15.4% (B) 9.1%
 (C) 10.5% (D) 12.5%

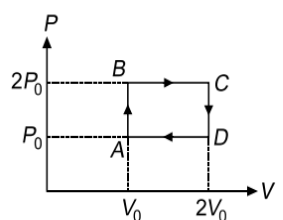

2.148 JEE Advanced Physics: Waves and Thermodynamics

- 226.** The freezing point on a thermometer is marked as -20° and the boiling point as 130° . A temperature of human body (34°C) on this thermometer will be read as
 (A) 31° (B) 51°
 (C) 20° (D) None of these
- 227.** An object is at the temperature of 400°C . At what temperature would it radiate twice as fast? The temperature of the surroundings may be assumed to be negligible
 (A) 200°C (B) 200K
 (C) 200F (D) 800K
- 228.** When 10 moles of an ideal diatomic gas having initial volume V_0 and temperature T_0 respectively is allowed to expand at constant pressure by supplying $3.5RT_0$ amount of heat, then the final volume and temperature of the gas are
 (A) $1.1V_0, 1.1T_0$ (B) $0.9V_0, 0.9T_0$
 (C) $1.1V_0, 0.9T_0$ (D) $0.9V_0, 1.1T_0$
- 229.** A gas thermometer is used as a standard thermometer for measurement of temperature. When the gas container of the thermometer is immersed in water at its triple point 273.16K , the pressure in the gas thermometer reads $3 \times 10^4\text{Nm}^{-2}$. When the gas container of the same thermometer is immersed in another system, the gas pressure reads $3.5 \times 10^4\text{Nm}^{-2}$. The temperature of this system is
 (A) 234.13K (B) -38.86°C
 (C) 318.69°C (D) 45.5°C
- 230.** The temperature at which the velocity of oxygen will be half of that of hydrogen at N.T.P. is
 (A) 1092°C (B) 1492K
 (C) 273K (D) 819°C
- 231.** A cooking pot should have
 (A) high specific heat and low conductivity
 (B) high specific heat and high conductivity
 (C) low specific heat and low conductivity
 (D) low specific heat and high conductivity
- 232.** Two vessels A and B of different materials are similar in shape and size. The same quantity of ice filled in them melts in times t_1 and t_2 respectively. The ratio of the thermal conductivities of A and B is
 (A) $t_1 : t_2$ (B) $t_2 : t_1$
 (C) $t_1^2 : t_2^2$ (D) $t_2^2 : t_1^2$
- 233.** An ideal monatomic gas undergoes a cyclic process $ABCA$ as shown in the figure. The ratio of heat absorbed during AB to the work done on the gas during BC is
 (A) $\frac{5}{2\log_e 2}$
 (B) $\frac{5}{3}$
 (C) $\frac{5}{4\log_e 2}$
 (D) $\frac{5}{6}$

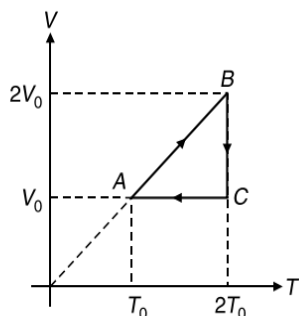

- 234.** Two rods of same length 20cm , of metals A and B , expand by 0.02cm and 0.04cm respectively when their temperature is raised from 20°C to 60°C . A composite rod of length 20cm is made by joining two rods of metal A and B . This rod expands by 0.025cm for same change in temperature. Length of part made of metal A is
 (A) 20cm (B) 10cm
 (C) 15cm (D) 18cm
- 235.** The molar specific heat of an ideal gas (C)
 (A) cannot be negative
 (B) must lie in the range starting from C_V and terminating at C_P i.e. $C_V \leq C \leq C_P$
 (C) must equal either C_P or C_V
 (D) may have any value lying between $-\infty$ and ∞
- 236.** A gaseous mixture of 4g of oxygen and 2g of helium expands adiabatically and reversibly from 20litre to 30litre . The initial temperature is 117°C . The final temperature (in kelvin) is
 (A) $390 \times \left(\frac{2}{3}\right)^{\frac{10}{17}}$ (B) $390 \times \left(\frac{2}{3}\right)^{\frac{27}{17}}$
 (C) $390 \times \left(\frac{2}{3}\right)$ (D) $390 \times \left(\frac{3}{2}\right)^{\frac{10}{17}}$
- 237.** A column of liquid is contained in a horizontal tube which is open at both ends. The change in temperature does not alter the length of this liquid column in the tube. If α be the coefficient of linear expansion of the material of the tube and γ be the coefficient of volume expansion of the liquid then
 (A) $\gamma = 3\alpha$ (B) $\gamma = 2\alpha$
 (C) $\gamma = \alpha$ (D) $\gamma = \frac{1}{2}\alpha$
- 238.** Pressure versus temperature graph of an ideal gas is as shown in figure corresponding density (ρ) versus volume (V) graph will be

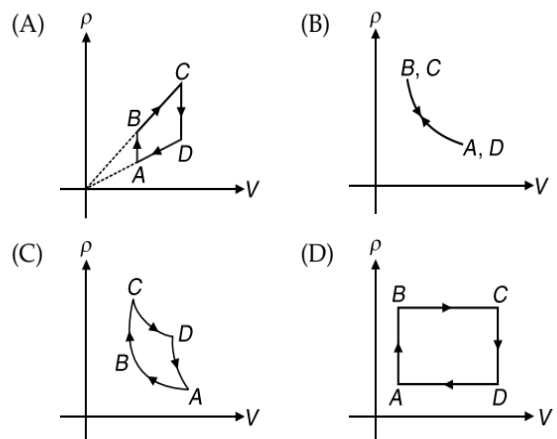
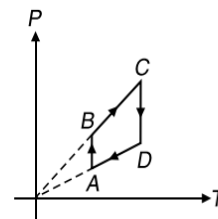

239. A faulty thermometer has its fixed points marked as 10° and 90° . Temperature of a body as measured by the faulty thermometer is the correct temperature of the body on celsius scale. The temperature of body is
 (A) 60°C (B) 55°C
 (C) 50°C (D) 52°C
240. An object is cooled from 75°C to 65°C in 2 minute in a room at 30°C . The time taken to cool the same object from 55°C to 45°C in the same room is
 (A) 5 minute (B) 3 minute
 (C) 4 minute (D) 2 minute
241. The amount of heat required to raise the temperature of 1 mole of a monatomic gas from 20°C to 30°C at constant volume is H . Then the amount of heat required to raise the temperature of 2 mole of a diatomic gas from 20°C to 25°C at constant pressure is
 (A) $2H$ (B) $\frac{4}{3}H$
 (C) $\frac{5}{3}H$ (D) $\frac{7}{3}H$
242. A mass of gas is first expanded isothermally and then compressed adiabatically to its original volume. Further simplest operation performed on the gas to restore it to its original state is
 (A) an isobaric cooling to bring its temperature to initial value.
 (B) an isochoric cooling to bring its pressure to its initial value.
 (C) an isobaric heating to bring its temperature to initial value.
 (D) an isochoric heating to bring its temperature to initial value.
243. A cylinder of radius R made of a material of thermal conductivity k_1 is surrounded by a cylindrical shell of inner radius R and outer radius $2R$ made of a material of thermal conductivity k_2 . The two ends of the combined system are maintained at two different temperatures. There is no loss of heat across the cylindrical surface and the system is in the steady state. The effective conductivity of the system is
 (A) $k_1 + k_2$ (B) $\frac{k_1 k_2}{k_1 + k_2}$
 (C) $\frac{k_1 + 3k_2}{4}$ (D) $\frac{3k_1 + k_2}{4}$
244. In a container of negligible heat capacity 100 g of a liquid at 20°C is heated. Specific heat of liquid varies with temperature T as $c = (100T + 500) \text{ J kg}^{-1} \text{ }^\circ\text{C}^{-1}$, where T is in $^\circ\text{C}$. The amount of heat required to raise the temperature of the liquid to 40°C is
 (A) 5000 J (B) 6000 J
 (C) 7000 J (D) 8000 J
245. P - V diagram of a diatomic gas is a straight line passing through origin. The molar heat capacity of the gas in the process will be

- (A) $4R$ (B) $2.5R$
 (C) $3R$ (D) $\frac{4R}{3}$

246. If $\alpha_{\text{brass}} = 18 \times 10^{-6} (\text{ }^\circ\text{C})^{-1}$ and $\alpha_{\text{iron}} = 12 \times 10^{-6} (\text{ }^\circ\text{C})^{-1}$, then the lengths of brass and iron taken so that the difference between them is always 0.1 m for any variation in temperature are respectively
 (A) 0.3 m, 0.4 m (B) 0.4 m, 0.3 m
 (C) 0.2 m, 0.3 m (D) 0.3 m, 0.2 m
247. The molar specific heat in a process carried on a diatomic gas if the gas does a work of $\frac{Q}{4}$ when a heat Q is supplied to it is
 (A) $\frac{2R}{5}$ (B) $\frac{5R}{2}$
 (C) $\frac{10R}{3}$ (D) $\frac{6R}{7}$
248. A gas is expanded from volume V_0 to $2V_0$ under three different processes. Process 1 is isobaric, process 2 is isothermal and process 3 is adiabatic. Let ΔU_1 , ΔU_2 and ΔU_3 be the change in internal energy of the gas in these three processes. Then
 (A) $\Delta U_1 > \Delta U_2 > \Delta U_3$
 (B) $\Delta U_1 < \Delta U_2 < \Delta U_3$
 (C) $\Delta U_2 < \Delta U_1 < \Delta U_3$
 (D) $\Delta U_2 < \Delta U_3 < \Delta U_1$

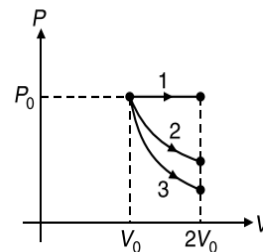

249. The graph shows the variation of temperature (θ) of one kilogram of a material with the heat (H) supplied to it. At O , the substance is in the solid state. From the graph, we can conclude that

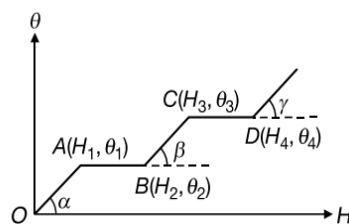

- (A) θ_2 is the melting point of the solid
 (B) BC represents the change of state from solid to liquid
 (C) $(H_2 - H_1)$ represents the latent heat of fusion of the substance
 (D) $(H_3 - H_1)$ represents the latent heat of vaporization of the liquid
250. In the following graph, X and Y are two curves corresponding to different masses of the same gas in two identical vessels. The ratio of mass in Y to that in X is
 (A) $1 : \sqrt{3}$
 (B) $1 : 3$
 (C) $2 : 3$
 (D) $2 : \sqrt{3}$

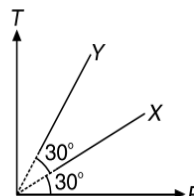

2.150 JEE Advanced Physics: Waves and Thermodynamics

251. Two cylinders fitted with pistons contain equal amounts of an ideal diatomic gas at 300 K. The piston of A is free to move, while that of B is held fixed. The same amount of heat is given to the gas in each cylinder. If the rise in temperature of the gas in A is 30 K, then the rise in temperature of gas in B is
- (A) 30 K (B) 18 K
(C) 50 K (D) 42 K

252. One mole of a monatomic ideal gas undergoes the process $A \rightarrow B$ in the given P - V diagram. The specific heat for this process is

- (A) $\frac{3R}{2}$
(B) $\frac{13R}{6}$
(C) $\frac{5R}{2}$
(D) $2R$

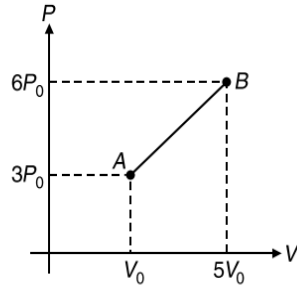

253. A gas undergoes a process in which its pressure P and volume V are related as $PV^n = \text{constant}$, where n is a constant. In this process it is observed that the work is done at the expense of internal energy for
- (A) $n = \gamma - 1$ (B) $n = \gamma + 1$
(C) $n = \gamma$ (D) $n = 1 - \gamma$

254. Two isochoric processes AB and CD are shown in P - V diagram for the same sample of gas. Heat exchange will be
- (A) more in process AB
(B) same in both processes
(C) more in process CD
(D) zero in both processes

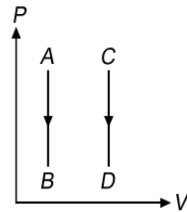

255. Three conducting rods of same material and cross-section are shown in figure. Temperature of A , D and C are maintained at 20°C , 90°C and 0°C . The ratio of lengths of BD and BC if there is no heat flow in AB is

- (A) $\frac{2}{7}$
(B) $\frac{7}{2}$
(C) $\frac{9}{2}$
(D) $\frac{2}{9}$

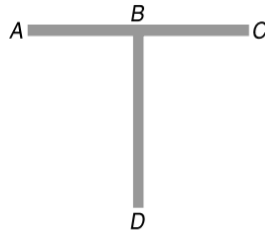

256. Pressure versus temperature graph of an ideal gas is as shown in figure. Density of the gas at point A is ρ_0 . Density at B will be

- (A) $\frac{3}{4}\rho_0$
(B) $\frac{3}{2}\rho_0$
(C) $\frac{4}{3}\rho_0$
(D) $2\rho_0$

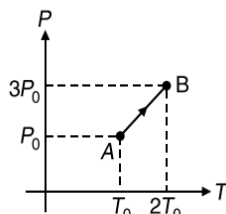

257. Three identical vessels have gases at the same temperature and pressure. The first vessel contains neon (monatomic), the second contains chlorine (diatomic) and the third contains uranium hexafluoride (polyatomic). If n_1, n_2, n_3 be the number of moles and v_1, v_2, v_3 the rms velocity of gases in vessel 1, 2 and 3 respectively, then
- (A) $n_1 > n_2 > n_3$ and $v_1 > v_2 > v_3$
(B) $n_1 < n_2 < n_3$ and $v_1 < v_2 < v_3$
(C) $n_1 = n_2 = n_3$ and $v_1 = v_2 = v_3$
(D) $n_1 = n_2 = n_3$ and $v_1 > v_2 > v_3$

258. The coefficient of linear expansion of iron is 0.000011 K^{-1} . An iron rod is 10 m long at 27°C . The length of the rod will be decreased by 1.1 mm when the temperature of the rod changes to
- (A) 0°C (B) 10°C
(C) 17°C (D) 20°C

259. Pressure versus temperature graph of an ideal gas of equal number of moles of different volumes are plotted as shown in figure. Choose the correct alternative
- (A) $V_1 = V_2, V_3 = V_4$ and $V_2 > V_3$
(B) $V_1 = V_2, V_3 = V_4$ and $V_2 < V_3$
(C) $V_1 = V_2 = V_3 = V_4$
(D) $V_4 > V_3 > V_2 > V_1$

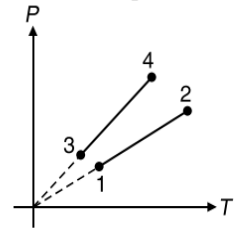

260. Resistance of a platinum resistance thermometer is 2 ohm at 20°C , 4 ohm at 100°C and 2.2 ohm at some temperature of $T^\circ\text{C}$. Then T is
- (A) 7 (B) 14
(C) 21 (D) 28

261. A cyclic process is shown in the p - T diagram. which of the curves show the same process on a V - T diagram?

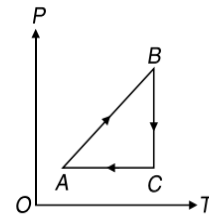

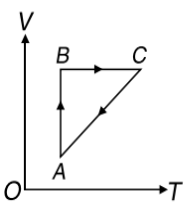
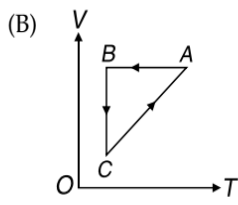
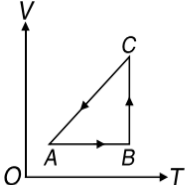
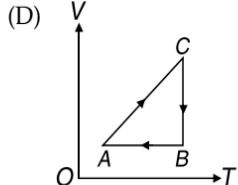
- (A) 
- (B) 
- (C) 
- (D) 

262. A system S receives heat continuously from an electrical heater of power 10 W. The temperature of S becomes constant at 50°C when the surrounding temperature is 20°C .

After the heater is switched off, S cools from 35.1°C to 34.9°C in 1 minute. The heat capacity of S is

- (A) $750\text{ J}(\text{}^\circ\text{C})^{-1}$ (B) $1500\text{ J}(\text{}^\circ\text{C})^{-1}$
 (C) $3000\text{ J}(\text{}^\circ\text{C})^{-1}$ (D) $6000\text{ J}(\text{}^\circ\text{C})^{-1}$

263. A box contains N molecules of a perfect gas at temperature T_1 and pressure P_1 . The number of molecules in the box is doubled keeping the total kinetic energy of the gas same as before. If the new pressure is P_2 and temperature T_2 , then

- (A) $P_2 = P_1, T_2 = T_1$ (B) $P_2 = P_1, 2T_2 = T_1$
 (C) $P_2 = 2P_1, T_2 = T_1$ (D) $P_2 = 2P_1, 2T_2 = T_1$

264. n mole of an ideal gas is supplied heat such that its temperature changes from T_1 to T_2 and pressure from P_1 to P_2 . If ΔS is the change in entropy of the system then

- (A) $\Delta S = nC_V \ln\left(\frac{T_2}{T_1}\right) + nR \ln\left(\frac{V_2}{V_1}\right)$
 (B) $\Delta S = nC_V \ln\left(\frac{T_2}{T_1}\right)$
 (C) $\Delta S = nR \ln\left(\frac{V_2}{V_1}\right)$

(D) Data insufficient to arrive at conclusion

265. An ideal gas is taken through $A \rightarrow B \rightarrow C \rightarrow A$, as shown in figure. If the net heat supplied to the gas in the cycle is 5 J , the work done by the gas in the process $C \rightarrow A$ is

- (A) -5 J (B) -10 J
 (C) -15 J (D) -20 J

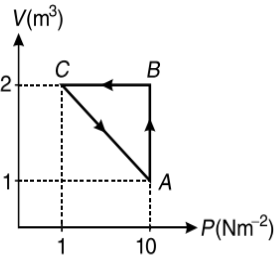

266. If on heating a liquid through 80°C in a vessel, the mass overflow from the vessel is $\left(\frac{1}{100}\right)^{\text{th}}$ of mass still remaining, the coefficient of apparent expansion of liquid is about

- (A) $1.25 \times 10^{-4} \text{ }^\circ\text{C}^{-1}$ (B) $2.5 \times 10^{-4} \text{ }^\circ\text{C}^{-1}$
 (C) $1.25 \times 10^{-5} \text{ }^\circ\text{C}^{-1}$ (D) $2.5 \times 10^{-5} \text{ }^\circ\text{C}^{-1}$

267. A sample of an ideal gas is taken through a cycle as shown in figure. It absorbs 50 J of energy during the process AB , no heat during BC , rejects 70 J during CA . If 40 J of work is done on the gas during BC , internal energy of gas at A is 1500 J , then the internal energy at C would be

- (A) 1590 J (B) 1620 J
 (C) 1540 J (D) 1570 J

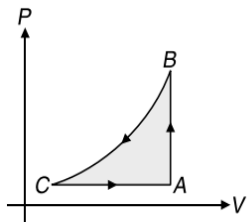

268. If a 60 kg man is having a temperature of 103°F . Assuming the specific heat of human body to be $1\text{ cal g}^{-1}(\text{}^\circ\text{C})^{-1}$, the heat required to raise the temperature of the body to this level from the normal body temperature of 98.4°F is

- (A) 122 cal (B) 154 kcal
 (C) 66 kcal (D) 184 kcal

269. n_1 mole of a monatomic gas is mixed with n_2 mole of diatomic gas such that $\gamma_{\text{mixture}} = 1.5$

- (A) $n_1 = 2n_2$ (B) $n_2 = 2n_1$
 (C) $n_1 = n_2$ (D) $n_1 = 3n_2$

270. Heat is supplied to a diatomic gas at constant pressure. The ratio of $\Delta Q : \Delta U : \Delta W$ is

- (A) $5 : 3 : 2$ (B) $5 : 2 : 3$
 (C) $7 : 5 : 2$ (D) $7 : 2 : 5$

271. A perfect gas goes from state A to another state B by absorbing $8 \times 10^5\text{ J}$ of heat and doing $6.5 \times 10^5\text{ J}$ of external work. It is now transferred between the same two states in another process in which it absorbs 10^5 J of heat. Then in the second process, work done

- (A) on gas is $0.5 \times 10^5\text{ J}$ (B) by gas is $0.5 \times 10^5\text{ J}$
 (C) on gas is 10^5 J (D) by gas is 10^5 J

272. Pressure versus temperature graphs of an ideal gas are as shown in figure. Select the incorrect statement.

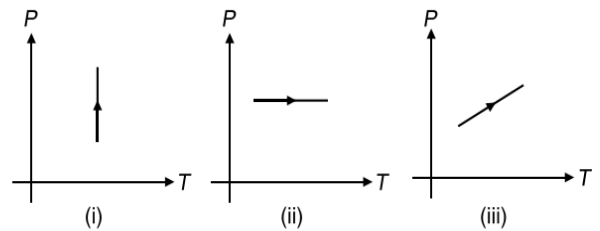

- (A) Density of gas is increasing in graph (i)
 (B) Density of gas is decreasing in graph (ii)
 (C) Density of gas is constant in graph (iii)
 (D) None of these

273. For a gas $\frac{R}{C_p} = \frac{2}{3}$. Possibly the gas is

- (A) diatomic (B) monatomic
 (C) a mixture of diatomic and monatomic
 (D) polyatomic

274. The dimensional representation of thermal resistance is

- (A) $ML^{-2}T^{-2}K^{-1}$ (B) $M^{-1}L^{-2}T^3K$
 (C) $ML^2T^{-3}K^{-2}$ (D) $ML^2T^{-2}K^{-2}$

275. An ideal heat engine exhausting heat at 27°C is to have a 60% efficiency. It must take heat at

- (A) 327°C (B) 373°C
 (C) 477°C (D) 573°C

276. Pressure P , volume V and temperature T of a certain material are related by $P = \frac{\alpha T^2}{V}$. Here α is a constant. The work done by the material when temperature changes from T_0 to $2T_0$ while pressure remains constant is

- (A) $6\alpha T_0^3$ (B) $\frac{3}{2}\alpha T_0^2$
 (C) $2\alpha T_0^2$ (D) $3\alpha T_0^2$

2.152 JEE Advanced Physics: Waves and Thermodynamics

277. The relation between U , P and V for an ideal gas is $U = 2 + 3PV$. The gas is
 (A) monatomic
 (B) diatomic
 (C) polyatomic
 (D) either a monatomic or diatomic

278. An ideal gas taken through the cyclic process $a \rightarrow b \rightarrow c \rightarrow a$ absorbs 100 J of heat during the part ab , no heat during $b \rightarrow c$, 50 J of work is done on the gas during the part $b \rightarrow c$. If internal energy of the gas at a is 1200 J, then change in internal energy in $c \rightarrow a$ process is

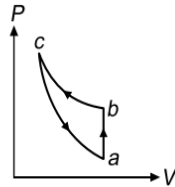

- (A) 100 J
 (B) -150 J
 (C) 150 J
 (D) -1050 J
279. The temperature of a gas contained in a closed vessel increases by 1°C when pressure of the gas is increased by 1%. The initial temperature of the gas is
 (A) 100 K (B) 100°C
 (C) 250 K (D) 250°C

280. A certain gas is filled in two identical containers at pressures P_1 and P_2 and absolute temperatures T_1 and T_2 respectively. When the vessels are joined, the gases intermix and reach a common pressure P and common temperature T . Then $\frac{P}{T}$ equals

(A) $\frac{1}{2} \left(\frac{P_1}{T_1} + \frac{P_2}{T_2} \right)$ (B) $\frac{P_1 T_2 + P_2 T_1}{(T_1 + T_2)^2}$
 (C) $\frac{P_1 T_1 + P_2 T_2}{(T_1 + T_2)^2}$ (D) $\left(\frac{P_1}{T_1} + \frac{P_2}{T_2} \right)$

281. A gas, is heated at constant pressure. The fraction of heat supplied used for external work is

(A) $\frac{1}{\gamma}$ (B) $\left(1 - \frac{1}{\gamma} \right)$
 (C) $\gamma - 1$ (D) $\left(1 - \frac{1}{\gamma^2} \right)$

282. A gas at pressure P_0 is contained in a vessel. If the masses of all the molecules are halved and their speeds doubled, the resulting pressure would be

(A) $4P_0$ (B) $2P_0$
 (C) P_0 (D) $\frac{P_0}{2}$

283. The rms speed of molecules of a gas contained in a vessel moving with a speed v is \bar{c} as seen by a person moving with the vessel. Then pressure exerted by the gas is

(A) $\frac{1}{3} \rho (\bar{c})^2$ (B) $\frac{1}{3} \rho (\bar{c} + v)^2$
 (C) $\frac{1}{3} \rho (\bar{c} - v)^2$ (D) $\frac{1}{3} \rho [(\bar{c})^2 - v^2]$

284. The internal energy of an ideal gas is
 (A) ZERO (B) PV
 (C) $\frac{PV}{\gamma - 1}$ (D) $\frac{\gamma PV}{\gamma - 1}$

285. A body having a surface area of 5.0 cm^2 , radiates 300 J of energy per minute at a temperature of 727°C . The emissivity of the body is

(Stefan's constant is $5.67 \times 10^{-8} \text{ Wm}^{-2}\text{K}^{-4}$)
 (A) 0.09 (B) 0.18
 (C) 0.36 (D) 0.54

286. One mole of an ideal monatomic gas is taken from point A to C along the path ABC. The initial temperature at A is T_0 . For the process $A \rightarrow B \rightarrow C$,

- (A) heat absorbed is $0.5RT_0$
 (B) heat liberated is $2RT_0$
 (C) change in internal energy is zero
 (D) work done is zero

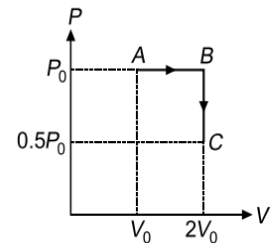

287. The plot of isotherms will not be a straight line when a plot is drawn between

- (A) PV and V (B) S (entropy) and T
 (C) V and P (D) P and T

288. The following are the observations made by five students in measuring C_p and C_v in $\text{cal mol}^{-1}(\text{C}^\circ)^{-1}$ respectively. Which would you consider as the most reliable observation?

- (A) 5 and 3 (B) 4 and 6
 (C) 5 and 7 (D) 4 and 3

289. For an ideal monatomic gas, the universal gas constant R is n times the molar heat capacity at constant pressure C_p . Here n is

- (A) 0.67 (B) 1.4
 (C) 0.4 (D) 1.67

290. If most probable speed of the molecules of certain diatomic gas at room temperature is found to be about 1.6 kms^{-1} , then the gas is

- (A) O_2 (B) N_2
 (C) H_2 (D) CO_2

291. n moles of a gas expands from volume V_1 to V_2 such that external work done equals the heat supplied. The work done by the gas is

(A) $nRT \left(\frac{V_2}{V_1} \right)$ (B) $nRT \left(\frac{V_2}{V_1} - 1 \right)$
 (C) $nRT \ln \left(\frac{V_2}{V_1} \right)$ (D) $nRT \ln \left(\frac{V_2}{V_1} + 1 \right)$

292. A metallic rod of unit length and unit area of cross section is heated through 1°C . If the Young's modulus of elasticity is E and the linear expansivity is $\alpha (\text{C}^\circ)^{-1}$, then the compressional force required to prevent the rod from expanding is

- (A) $E\alpha$ (B) $\frac{\alpha}{E}$
 (C) $\frac{E}{\alpha}$ (D) $3E\alpha$

293. Let Q_1 and Q_2 be the respective heats supplied to the gas in processes shown in Figure-I and Figure-II, then

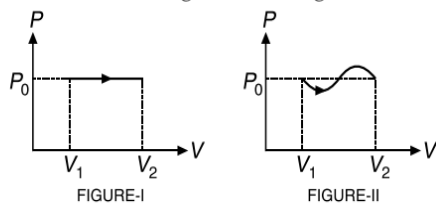

- (A) $Q_1 = Q_2$ (B) $Q_1 > Q_2$
 (C) $Q_1 < Q_2$ (D) $Q_1 \gg Q_2$
294. A point source of heat of power P is placed at the centre of a spherical shell of mean radius R . The material of the shell has thermal conductivity k . If the temperature difference

between the outer and the inner surface of the shell is not to exceed T , then the thickness of the shell should not be less than

- (A) $\frac{2\pi R^2 k T}{P}$ (B) $\frac{4\pi R^2 k T}{P}$
 (C) $\frac{\pi R^2 k T}{P}$ (D) $\frac{\pi R^2 k T}{4P}$

295. A sealed container with negligible coefficient of expansion contained helium. When it is heated from 27°C to 327°C , the average kinetic energy of helium becomes

- (A) 12 times (B) 8 times
 (C) 4 times (D) 2 times

MULTIPLE CORRECT CHOICE TYPE QUESTIONS

This section contains Multiple Correct Choice Type Questions. Each question has four choices (A), (B), (C) and (D), out of which ONE OR MORE is/are correct.

1. Internal energy of an ideal diatomic gas at 300 K is 100 J. Out of this 100 J
 (A) potential energy is zero
 (B) rotational kinetic energy is 40 J
 (C) translational kinetic energy is 60 J
 (D) translational kinetic energy is 100 J
2. A gas undergoes the change in its state from position A to position B via three different paths as shown in figure. Select the correct alternative(s).

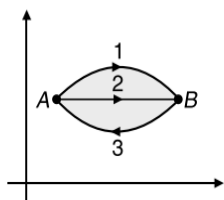

- (A) Change in internal energy in all the three paths is equal
 (B) In all the three paths heat is absorbed by the gas
 (C) Heat absorbed/released by the gas is maximum in path 1
 (D) Temperature of the gas first increases and then decreases continuously in path 1
3. A steel drill making 180 rpm is used to drill a hole in a block of steel. The mass of the steel block and the drill is 180 g each. The entire mechanical work is used up in producing heat such that the rate of rise of temperature of the block is 0.5°C s^{-1} . P is the power rating of the drill and τ is the couple required to drive the drill. (Given specific heat of steel $c_{\text{steel}} = 0.10 \text{ cal g}^{-1} (\text{C}^\circ)^{-1}$)
 (A) $P = 37.8 \text{ W}$ (B) $P = 9 \text{ W}$
 (C) $\tau = 2 \text{ Nm}$ (D) $\tau = 6.3 \text{ Nm}$

4. The molar specific heat for a gas may have a value given by

- (A) $C_V = \frac{dU}{dT}$ (B) $C_P = \left(\frac{dQ}{dT}\right)_P$
 (C) $C = \frac{dU}{dT} + P \frac{dV}{dT}$ (D) Data Insufficient

5. Which of the following quantities is independent of the nature of the gas at same temperature

- (A) the number of molecules in 1 mole
 (B) the number of molecules in equal volume
 (C) the translational kinetic energy of 1 mole
 (D) the kinetic energy of unit mass

6. Two spheres A and B have same radius but the heat capacity of A is greater than that of B . The surfaces of both are painted black. They are heated to the same temperature and allowed to cool. Then

- (A) A cools faster than B
 (B) both A and B cool at the same rate
 (C) at any temperature the ratio of their rates of cooling is a constant
 (D) B cools faster than A

7. Number of collisions per unit area of molecules of a gas on the wall of a container will increase when the

- (A) temperature and volume both are doubled
 (B) temperature and volume both are halved
 (C) pressure and temperature both are doubled
 (D) None of above

8. One end of the metal rod of area A and length l is kept in steam. A steady state is reached after some time in which the amount of heat passing through any cross-section of rod per second is Q . Q will increase if

- (A) A is increased
 (B) l is increased
 (C) the room temperature is increased
 (D) the room temperature is decreased

9. The temperature drop through a two layer furnace wall is 900°C . Each layer is of equal area of cross section. Which of the following actions will result in lowering the temperature T of the interface?

2.154 JEE Advanced Physics: Waves and Thermodynamics

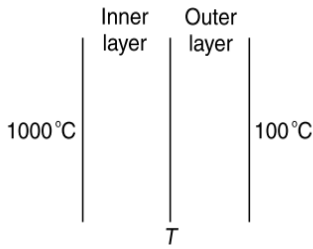

- (A) by increasing the thermal conductivity of outer layer
 - (B) by increasing thermal conductivity of inner layer
 - (C) by increasing thickness of outer layer
 - (D) by increasing thickness of inner layer
10. 1 kg of ice at 0°C is mixed with 1.5 kg of water at 45°C . If the latent heat of fusion of ice is 80 calg^{-1} , then
- (A) the temperature of the mixture is 0°C
 - (B) mixture contains 156.25 g of ice
 - (C) mixture contains 843.75 g of ice
 - (D) the temperature of the mixture is 15°C
11. Two rods of length L_1 and L_2 are made of materials of coefficients of linear expansions α_1 and α_2 respectively such that $L_1\alpha_1 = L_2\alpha_2$. The temperature of the rods is increased by ΔT and correspondingly the change in their respective lengths be ΔL_1 and ΔL_2 .
- (A) $\Delta L_1 \neq \Delta L_2$
 - (B) $\Delta L_1 = \Delta L_2$
 - (C) Difference in length ($L_1 - L_2$) is a constant and is independent of rise of temperature
 - (D) Data is insufficient to arrive at a conclusion
12. Two identical containers each of volume V_0 are joined by a small pipe. The containers contain identical gases at temperature T_0 and pressure P_0 . One container is heated to temperature $2T_0$ while maintaining the other at the same temperature. The common pressure of the gas is P and n is the number of moles of gas in container at temperature $2T_0$.
- (A) $P = 2P_0$
 - (B) $P = \frac{4}{3}P_0$
 - (C) $n = \frac{2 P_0 V_0}{3 RT_0}$
 - (D) $n = \frac{3 P_0 V_0}{2 RT_0}$
13. Two gases, initially having the same pressure, volume and temperature expand to the same volume, the first isothermally and the second adiabatically.
- (A) Greater work is done by the gas for isothermal process.
 - (B) The isothermal process has greater final pressure.
 - (C) The isothermal process has greater final temperature (same as initial value) in comparison to adiabatic process.
 - (D) Data is insufficient to arrive at a conclusion.
14. In PROBLEM 13, if compression is carried instead of expansion then
- (A) greater work is done on the gas for an adiabatic process.
 - (B) the adiabatic process has greater final pressure.
 - (C) the adiabatic process has greater final temperature due to the fact that adiabatic compression leads to heating.
 - (D) data is insufficient to arrive at a conclusion.

15. Consider a heat pump as shown in Figure. If $W > 0$, then the correct possibilities are
- (A) $Q_1 > Q_2 > 0$
 - (B) $Q_2 > Q_1 > 0$
 - (C) $Q_2 < Q_1 < 0$
 - (D) $Q_1 < 0, Q_2 > 0$

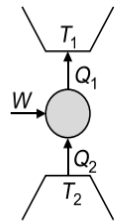

16. A monatomic gas of n moles undergoes a cyclic process ABCDA as shown in figure. Process AB is isobaric, BC is adiabatic, CD is isochoric and DA is isothermal. The maximum and minimum temperature in the cycle are $4T_0$ and T_0 respectively. Then

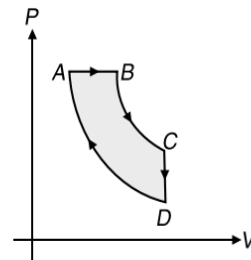

- (A) $T_B > T_C > T_D$
 - (B) heat is released by the gas in the process CD
 - (C) heat is supplied to the gas in the process AB
 - (D) total heat supplied to the gas is $2nRT_0 \log_e(2)$
17. A planet having surface temperature T K has a solar constant S . An angle θ is subtended by the sun at the planet.
- (A) $S \propto T^2$
 - (B) $S \propto T^4$
 - (C) $S \propto \theta^0$
 - (D) $S \propto \theta^2$
18. Two identical vessels contain helium and hydrogen at same temperature, then
- (A) average kinetic energy per mole of hydrogen is equal to the average kinetic energy per mole of helium
 - (B) average translational kinetic energy per mole of hydrogen is equal to the average translational kinetic energy per mole of helium
 - (C) average kinetic energy per mole of hydrogen is $\frac{3}{5}$ times the average kinetic energy per mole of helium
 - (D) average kinetic energy per mole of hydrogen is $\frac{5}{3}$ times the average kinetic energy per mole of helium
19. Select the incorrect statement(s).
- (A) A refrigerator is reverse of a heat engine.
 - (B) A heat pump is the same as a refrigerator.
 - (C) The coefficient of performance of a refrigerator can be infinite.
 - (D) In a heat engine, heat cannot be fully converted to work.
20. A body of mass m has gram specific heat c .
- (A) Heat capacity of the body is mc
 - (B) Water equivalent of the body is m
 - (C) Water equivalent of the body is mc
 - (D) Heat capacity of the body is c

21. A gas is found to obey the law $p^2V = \text{constant}$. The initial temperature and volume are T_0 and V_0 . If the gas expands to a volume $3V_0$, then
- (A) final temperature becomes $\sqrt{3}T_0$
 - (B) internal energy of the gas will increase
 - (C) final temperature becomes $\frac{T_0}{\sqrt{3}}$
 - (D) internal energy of the gas decreases

22. During the process $A-B$ of an ideal gas

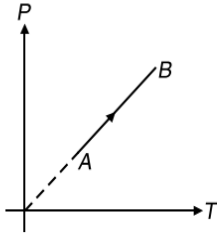

- (A) work done on the gas is zero
 - (B) density of the gas is constant
 - (C) slope of line AB from the T -axis is inversely proportional to the number of moles of the gas
 - (D) slope of line AB from the T -axis is directly proportional to the number of moles of the gas
23. One mole of an ideal gas in initial state A undergoes a cyclic process $ABCA$, as shown in the figure. Its pressure at A is P_0 . Choose the correct option(s) from the following.

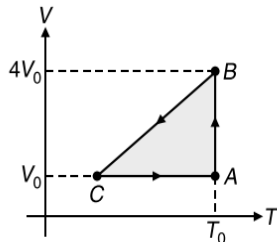

- (A) Internal energies at A and B are the same
 - (B) Work done by the gas in process AB is $P_0V_0 \log_e 4$
 - (C) Pressure at C is $\frac{P_0}{4}$
 - (D) Temperature at C is $\frac{T_0}{4}$
24. The density (ρ) of an ideal gas varies with temperature T as shown in figure. Then

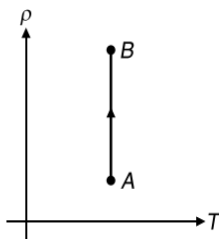

- (A) the product of P and V at A is equal to the product of P and V at B
- (B) pressure at B is greater than the pressure at A
- (C) work done by the gas during the process AB is negative
- (D) the change in internal energy from A to B is zero

25. A cyclic process of an ideal monatomic gas is shown in Figure. Select the correct statement(s)

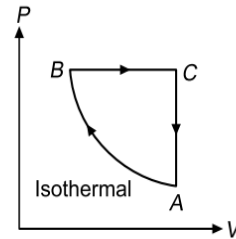

- (A) Work done by gas in process AB is more than that of the process BC .
 - (B) Net heat energy has been supplied to system.
 - (C) Temperature of gas is maximum in state B .
 - (D) In process CA , heat energy is rejected out by system.
26. At ordinary temperatures, the molecules of an ideal gas have only translational and rotational kinetic energies. At high temperatures they may also have vibrational energy. As a result of this at higher temperatures ($C_V = \text{molar heat capacity at constant volume}$)
- (A) $C_V = \frac{3}{2}R$ for a monatomic gas
 - (B) $C_V > \frac{3}{2}R$ for a monatomic gas
 - (C) $C_V < \frac{5}{2}R$ for a diatomic gas
 - (D) $C_V > \frac{5}{2}R$ for a diatomic gas

27. In the arrangement shown in figure. Gas is thermally insulated. An ideal gas is filled in the cylinder having pressure P_0 ($>$ atmospheric pressure P_a). Spring of force constant k is initially unstretched. Piston of mass m and area S is frictionless. In equilibrium piston rises up a distance x_0 , then

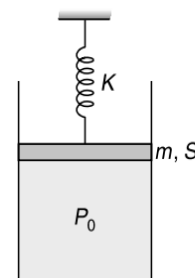

- (A) final pressure of the gas is $P_a + \frac{kx_0}{S} + \frac{mg}{S}$
 - (B) work done by the gas is $\frac{1}{2}kx_0^2 + mgx_0$
 - (C) decrease in internal energy of the gas is $\frac{1}{2}kx_0^2 + mgx_0 + P_a S x_0$
 - (D) All of the above
28. A thermally insulated chamber of volume $2V_0$ is divided by a frictionless piston of area S into two equal parts A and B . Part A has an ideal gas at pressure P_0 and temperature T_0 and in part B is vacuum. A massless spring of force constant

2.156 JEE Advanced Physics: Waves and Thermodynamics

k is connected with piston and the wall of the container as shown. Initially spring is unstretched. Gas in chamber A is allowed to expand. Let in equilibrium spring is compressed by x_0 . Then

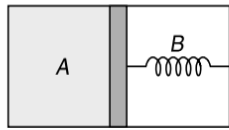

- (A) final pressure of the gas is $\frac{kx_0}{S}$
 - (B) work done by the gas is $\frac{1}{2}kx_0^2$
 - (C) change in internal energy of the gas is $\frac{1}{2}kx_0^2$
 - (D) temperature of the gas is decreased
29. In a thermodynamic process helium gas obeys the law $TP^{-2/5} = \text{constant}$. If temperature of 2 moles of the gas is raised from T to $3T$, then
- (A) heat given to the gas is $9RT$
 - (B) heat given to the gas is zero
 - (C) increase in internal energy is $6RT$
 - (D) work done by the gas is $-6RT$
30. The figure shows the P - V plot of an ideal gas taken through a cycle $ABCD$. The part ABC is a semi-circle and CDA is half of an ellipse. Then,

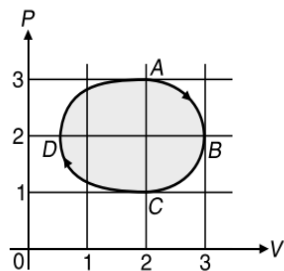

- (A) The process during the path $A \rightarrow B$ is isothermal.
 - (B) Heat flows out of the gas during the path $B \rightarrow C \rightarrow D$.
 - (C) Work done during the path $A \rightarrow B \rightarrow C$ is zero.
 - (D) Positive work is done by the gas in the cycle $ABCD$.
31. One mole of an ideal monatomic gas (initial temperature T_0) is made to go through the cycle $abca$ shown in the figure. If U denotes the internal energy, then choose the correct alternatives

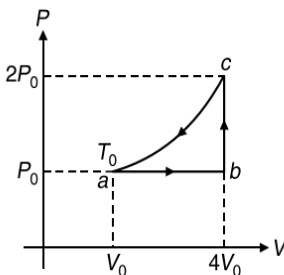

- (A) $U_c - U_a = 10.5RT_0$
- (B) $U_b - U_a = 4.5RT_0$
- (C) $U_c > U_b > U_a$
- (D) $U_c - U_b = 6RT_0$

32. Which of the following quantities depend on temperature only for a given ideal gas
- (A) internal energy of the gas
 - (B) product PV of the gas
 - (C) the ratio of pressure and density of the gas
 - (D) root mean square speed of the gas
33. Heat is supplied to 100 g of a solid (specific heat $0.5 \text{ kcal kg}^{-1} \text{ }^\circ\text{C}^{-1}$) till it boils. The graph between temperature and time is as follows. Then select the correct statement(s).

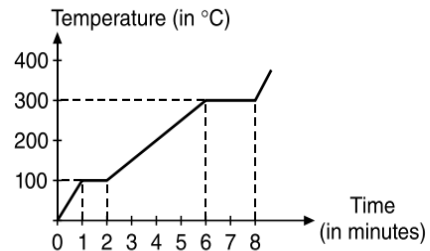

- (A) Heat supplied per minute is 5 kcal
 - (B) Boiling point is 300°C
 - (C) Specific heat in liquid state is $1 \text{ kcal kg}^{-1} \text{ }^\circ\text{C}^{-1}$
 - (D) None of these is correct
34. For a gas if C_p is the specific heat at constant pressure, C_v is the specific heat at constant volume, R is the Universal Gas constant and f be the degrees of freedom then
- (A) $f = \frac{2C_v}{R}$
 - (B) $f = 2\left(\frac{C_p}{R} - 1\right)$
 - (C) $f = \frac{C_v}{R}$
 - (D) $f = \frac{C_p}{R} - 1$
35. An ideal gas is heated from temperature T_1 to T_2 under various conditions. The correct statement(s) is/are
- (A) $\Delta U = nC_v(T_2 - T_1)$ for isobaric, isochoric and adiabatic processes
 - (B) Work is done at expense of internal energy in an adiabatic process and both have equal values
 - (C) $\Delta U = 0$ for an isothermal process
 - (D) $C = 0$ for an adiabatic process
36. n mole of an ideal gas is heated such that its temperature, pressure and volume, all three change simultaneously from T_1, P_1, V_1 to T_2, P_2, V_2 . Further in this process the specific heat equals zero. If W is the work done then
- (A) $W = \frac{nR}{1-\gamma}(T_2 - T_1)$
 - (B) $W = \frac{1}{1-\gamma}(P_2V_2 - P_1V_1)$
 - (C) $W = \frac{nR}{1+\gamma}(T_2 - T_1)$
 - (D) $W = \frac{1}{1+\gamma}(P_2V_2 - P_1V_1)$
37. Temperature versus pressure graph of an ideal gas is shown in figure. During the process AB

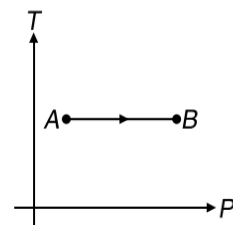

- (A) internal energy of the gas remains constant
 (B) volume of the gas is increased
 (C) work done by the atmosphere on the gas is positive
 (D) pressure is inversely proportional to volume
38. One mole of an ideal monatomic gas is taken from A to C along the path ABC. The temperature of the gas at A is T_0 . For the process ABC (R = universal gas constant)

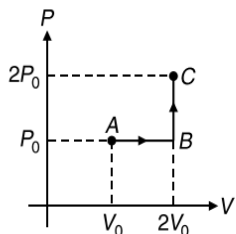

- (A) work done by the gas is RT_0
 (B) change in internal energy of the gas is $\frac{11}{2}RT_0$
 (C) heat absorbed by the gas is $\frac{11}{2}RT_0$
 (D) heat absorbed by the gas is $\frac{13}{2}RT_0$
39. C_p is always greater than C_v due to the fact that
- (A) no work is being done on heating the gas at constant volume.
 (B) when a gas absorbs heat at constant pressure its volume must change so as to do some external work.
 (C) the internal energy is a function of temperature only for an ideal gas.
 (D) for the same rise of temperature, the internal energy of a gas changes by a smaller amount at constant volume than at constant pressure.
40. In the Figure shown, the amount of heat supplied to one mole of an ideal gas is plotted on the horizontal axis and the amount work performed by the gas is drawn on the vertical axis. The graphs are isobars for different gases. The initial states of both gases are same. The curve

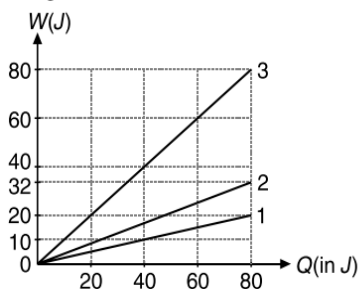

- (A) 1 corresponds to a polyatomic gas
 (B) 2 corresponds to a monatomic gas
 (C) 3 is not possible
 (D) All of these
41. A spherical black body of radius r , radiates a power P at temperature T when placed in surroundings at temperature T_0 ($\ll T$). If R is the rate of cooling then
- (A) $P \propto (T - T_0)$ (B) $P \propto T^4$
 (C) $P \propto r^2$ (D) $R \propto \frac{1}{r}$

42. In PROBLEM 41, if temperature of body is comparable to the temperature of surroundings then
- (A) $R \propto (T - T_0)$ (B) $R \propto \frac{1}{r^2}$
 (C) $R \propto \frac{1}{r}$ (D) $R \propto (T^4 - T_0^4)$

43. Two ends of area A of a uniform rod of thermal conductivity k are maintained at different but constant temperatures. At any point on the rod, the temperature gradient is $\frac{dT}{dl}$. If I be the thermal current in the rod, then
- (A) $I \propto A$ (B) $I \propto \frac{dT}{dl}$
 (C) $I \propto A^0$ (D) $I \propto \left(\frac{dT}{dl}\right)^{-1}$

44. A metal rod of length L_0 , made of material of Young's modulus Y , area A is fixed between two rigid supports. The coefficient of linear expansion of the rod is α . The rod is heated such that the tension in the rod is T
- (A) $T \propto L_0$ (B) $T \propto A_0^0$
 (C) $T \propto A$ (D) $T \propto L_0^0$

45. P - V diagram of a cyclic process ABCA is as shown in figure. Select the correct statement(s).

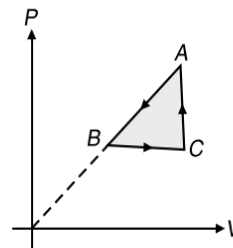

- (A) $Q_{A \rightarrow B}$ = negative (B) $\Delta U_{B \rightarrow C}$ = positive
 (C) $\Delta U_{C \rightarrow A}$ = negative (D) W_{CAB} = negative

46. The quantity $\frac{mkT}{V}$ of an ideal gas depends on (m is the mass of the gas, k is the Boltzmann's Constant)
- (A) temperature of the gas
 (B) volume of the gas
 (C) pressure of the gas
 (D) nature of the gas

47. An ideal gas undergoes the cyclic process shown in an isotherm below.

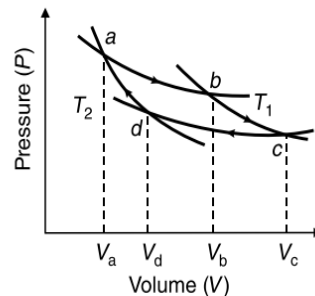

- (A) $T_1 = T_2$ (B) $T_1 > T_2$
 (C) $V_a V_c = V_b V_d$ (D) $V_a V_b = V_c V_d$

2.158 JEE Advanced Physics: Waves and Thermodynamics

48. Let ΔU_1 and ΔU_2 be change in internal energy in process A and B respectively, Q and W be the net heat given and net work done by the system in the cyclic process A+B as shown in Figure, then select the correct statement(s).

- (A) $\Delta U_1 + \Delta U_2 = 0$
- (B) $\Delta U_1 - \Delta U_2 = 0$
- (C) $Q - W = 0$
- (D) $Q + W = 0$

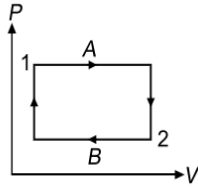

49. A heat engine absorbs heat at 327°C and exhausts heat at 127°C . The efficiency of engine is η and the maximum amount of work performed by the engine per kilocalorie of heat input is W .

- (A) $\eta = 0.38$
- (B) $\eta = 0.33$
- (C) $W = 1596 \text{ J}$
- (D) $W = 1400 \text{ J}$

50. A vessel X contains 1 mole of O_2 gas (molar mass 32) at a temperature T and pressure P . Another identical vessel Y contains one mole of He gas (molar mass 4) at temperature $2T$, then

- (A) pressure in the container Y is $\frac{P}{8}$
- (B) kinetic energy of O_2 molecule = kinetic energy of He molecule
- (C) pressure in the container Y is $2P$
- (D) kinetic energy of He molecule = $\frac{6}{5}$ (kinetic energy of O_2 molecule)

51. The internal energy of a system remains constant when it undergoes

- (A) a cyclic process
- (B) an isothermal process
- (C) an adiabatic process
- (D) any process in which the heat given out by the system equals the work done on the system

52. Three moles of an ideal gas ($C_p = \frac{7}{2}R$) at pressure P_A and temperature T_A is isothermally expanded to twice its initial volume. It is then compressed at constant pressure to its original volume. Finally, the gas is compressed at constant volume to its original pressure P_A . The correct P - V and P - T diagrams indicating the process are

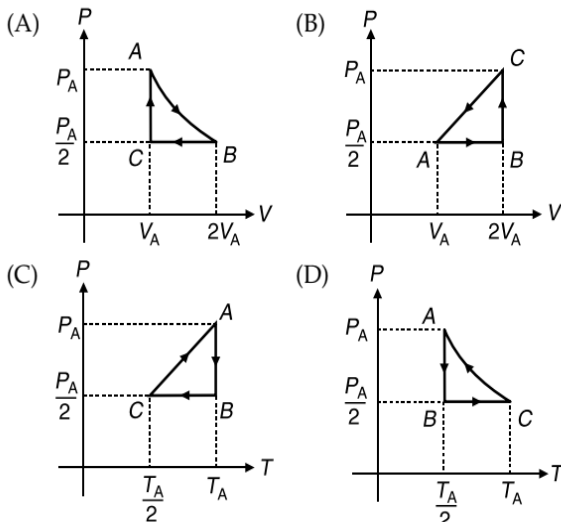

53. A cyclic process of an ideal monatomic gas is shown in Figure. Select the correct statement(s)

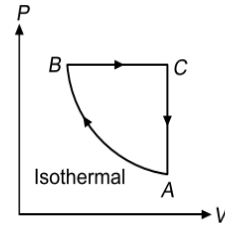

- (A) Work done by gas in process AB is more than that of the process BC.
- (B) Net heat energy has been supplied to system.
- (C) Temperature of gas is maximum in state B.
- (D) In process CA, heat energy is rejected out by system.

54. A bimetallic strip is made up of two metals with different α .

- (A) On heating, it bends towards the metal with high α .
- (B) On heating, it bends towards the metal with low α .
- (C) On cooling, it bends towards the metal with high α .
- (D) On cooling, it bends towards the metal with low α .

55. An ideal gas is allowed to expand against a vacuum in a rigid insulator container. Select the correct alternative(s).

- (A) Work done by the gas is zero
- (B) Pressure of the gas is inversely proportional to volume of the gas
- (C) Change in internal energy of the gas is zero
- (D) Temperature of the gas remains constant during expansion

56. n moles of an ideal monatomic gas undergoes a process in which the temperature changes with volume as $T = KV^2$. If the temperature of the gas changes from T_0 to $4T_0$ then

- (A) work done by the gas is $3nRT_0$
- (B) heat supplied of the gas is $6nRT_0$
- (C) work done by the gas is $\frac{3}{2}nRT_0$
- (D) heat supplied to the gas is $\frac{3}{2}nRT_0$

57. A uniform cylinder of steel of mass M , radius R is placed on frictionless bearings and set to rotate about its vertical axis with angular velocity ω_0 . After the cylinder has reached the specified state of rotation it is heated without any mechanical contact from temperature T_0 to $T_0 + \Delta T$. If $\frac{\Delta I}{I}$ is the fractional change in moment of inertia of the cylinder and $\frac{\Delta \omega}{\omega_0}$

be the fractional change in the angular velocity of the cylinder and α be the coefficient of linear expansion, then

- (A) $\frac{\Delta I}{I} = \frac{2\Delta R}{R}$
- (B) $\frac{\Delta I}{I} = -\frac{\Delta \omega}{\omega_0}$
- (C) $\frac{\Delta \omega}{\omega_0} = -2\alpha\Delta T$
- (D) $\frac{\Delta I}{I} = -\frac{2\Delta R}{R}$

58. In an isothermal expansion of a gas

- (A) pressure remains constant
- (B) temperature remains constant
- (C) rms velocity of gas molecules remains constant
- (D) density remains constant

59. For free expansion of an ideal gas in an insulated container, there is
 (A) no heat exchanged
 (B) work done
 (C) no change of internal energy
 (D) no change in pressure

60. n moles of an ideal gas undergoes a cyclic process in which it absorbs a heat Q_1 at constant temperature T_1 such that the expansion ratio is α . It rejects a heat Q_2 at constant temperature $T_2 (< T_1)$. The efficiency of the cyclic process is η , the total work done in the cyclic process is W and dU is the change in internal energy of the process.

(A) $\eta = 1 - \left(\frac{T_2}{T_1}\right)$

(B) $W = Q_1 - Q_2 = nR(T_1 - T_2) \log_e \alpha$

(C) $dU = 0$

(D) $dU = nRT_1 \log_e \alpha$

61. The indicator diagram for two processes 1 and 2 carried on an ideal gas is shown in figure. If m_1 and m_2 be the slopes $\left(\frac{dP}{dV}\right)$ for Process 1 and Process 2 respectively, then

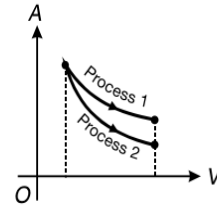

(A) $m_1 = m_2$

(B) $m_1 > m_2$

(C) $m_1 < m_2$

(D) $m_2 C_V = m_1 C_P$

REASONING BASED QUESTIONS

This section contains Reasoning type questions, each having four choices (A), (B), (C) and (D) out of which ONLY ONE is correct. Each question contains STATEMENT 1 and STATEMENT 2. You have to mark your answer as

Bubble (A) If both statements are TRUE and STATEMENT 2 is the correct explanation of STATEMENT 1.

Bubble (B) If both statements are TRUE but STATEMENT 2 is not the correct explanation of STATEMENT 1.

Bubble (C) If STATEMENT 1 is TRUE and STATEMENT 2 is FALSE.

Bubble (D) If STATEMENT 1 is FALSE but STATEMENT 2 is TRUE.

- Statement-1:** On a T - V graph (T on y -axis), the curve for adiabatic expansion would be a monotonically decreasing curve.
Statement-2: The slope of an adiabatic process represented on T - V graph is always positive.
- Statement-1:** The specific heat of a gas in an adiabatic process is zero and in an isothermal process is infinite.
Statement-2: Specific heat of a gas is directly proportional to change in heat and inversely proportional to change in temperature.
- Statement-1:** We can change the temperature of a body without giving (or taking) heat to (or from) it.
Statement-2: According to the Law of Conservation of Energy, total energy of a system should remain conserved.
- Statement-1:** When temperature difference across the two sides of a wall is increased, its coefficient of thermal conductivity increases.
Statement-2: Coefficient of thermal conductivity depends on nature of material of the wall.
- Statement-1:** V - T graph in a process is rectangular hyperbola. Then P - T graph in the same process will be a parabola.
Statement-2: If V - T graph is rectangular hyperbola, then V decrease when pressure increase.
- Statement-1:** A gas possesses a unique value of specific heat capacity.
Statement-2: Specific heat capacity is the heat required to raise the temperature of unit mass of the substance by one unit.
- Statement-1:** The isothermal curves intersect each other at a certain point.
Statement-2: The isothermal change takes place slowly, so, the isothermal curves have very little slope.
- Statement-1:** Specific heat of a gas at constant pressure is greater than its specific heat at constant volume.
Statement-2: At constant pressure, some heat is spent in expansion of the gas.
- Statement-1:** During an adiabatic expansion temperature of gas must decrease.
Statement-2: During adiabatic process $TV^{\gamma-1} = \text{constant}$, where γ is the adiabatic exponent of gas.
- Statement-1:** The coefficient of volume expansion at constant pressure for diatomic gas is more than that for monatomic gas.
Statement-2: The coefficient of volume expansion of gas at constant pressure is independent of the degrees of freedom of gas.
- Statement-1:** Two bodies at different temperatures, if brought in contact do not necessary settle to the mean temperature.
Statement-2: The two bodies may have different thermal capacities.
- Statement-1:** Melting point of ice decreases upon increase in pressure.
Statement-2: Volume of water is smaller than volume of ice.
- Statement-1:** Melting of solid causes no change in internal energy
Statement-2: Specific latent heat is the heat required to melt a unit mass of solid.

LINKED COMPREHENSION TYPE QUESTIONS

This section contains Linked Comprehension Type Questions or Paragraph based Questions. Each set consists of a Paragraph followed by questions. Each question has four choices (A), (B), (C) and (D), out of which only one is correct. (For the sake of competitiveness there may be a few questions that may have more than one correct options)

Comprehension 1

An amount Q of heat is given to a monatomic ideal gas in a process in which the gas performs a work $\frac{Q}{2}$ on its surroundings.

Based on the above facts, answer the following questions.

- The equation of the process discussed is given by
 - $PV^2 = \text{constant}$
 - $PV^3 = \text{constant}$
 - $P^3V = \text{constant}$
 - $P^2V = \text{constant}$
- Molar heat capacity of gas for the process is
 - R
 - $2R$
 - $3R$
 - $\frac{R}{2}$
- If at a temperature T_0 , the volume of gas is V_0 , then at temperature $T = 4T_0$, the volume of gas becomes
 - $4V_0$
 - $8V_0$
 - $\frac{V_0}{4}$
 - $16V_0$

Comprehension 2

Four moles of an ideal gas is initially in a state A having pressure $2 \times 10^5 \text{ Nm}^{-2}$ and temperature 200 K . Keeping the pressure constant, the gas is taken to state B at temperature of 400 K . The gas is then taken to a state C in such a way that its temperature increases and volume decreases. Also, from B to C , the magnitude of $\frac{dT}{dV}$ increases. The volume of gas at state C is equal to its volume at state A . Now gas is taken to initial state A keeping volume constant. A total of 1000 J of heat is withdrawn from the sample in the cyclic process. Taking $R = 8.3 \text{ Jmol}^{-1} \text{ K}^{-1}$. Based on the above facts, answer the following questions.

- The correct graph between temperature T and volume V for the cyclic process is

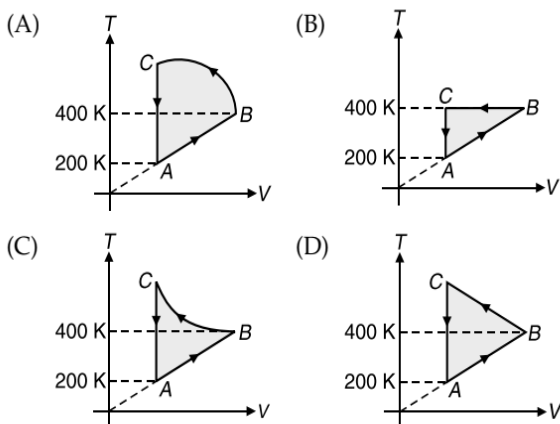

- The work done in path B to C is
 - 1000 J
 - -1000 J
 - -7640 J
 - 5640 J
- The volume of gas at state C is
 - 0.0332 m^3
 - 0.22 m^3
 - 0.332 m^3
 - 3.32 m^3

Comprehension 3

A small spherical monatomic ideal gas bubble $\left(\gamma = \frac{5}{3}\right)$ is trapped inside a liquid of density ρ_l (shown in figure). Assume that the bubble does not exchange any heat with the liquid. The bubble contains n moles of gas. The temperature of the gas when the bubble is at the bottom is T_0 , the height of the liquid is H and the atmospheric pressure is P_0 (Neglect surface tension). Based on the above facts, answer the following questions.

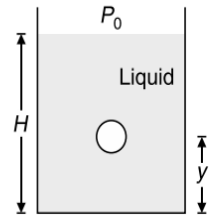

- As the bubble moves upwards, besides the buoyancy force the following forces are acting on it
 - Only the force of gravity
 - The force due to gravity and the force due to the pressure of the liquid
 - The force due to gravity, the force due to the pressure of the liquid and the force due to viscosity of the liquid
 - The force due to gravity and the force due to viscosity of the liquid
- When the gas bubble is at a height y from the bottom, its temperature is
 - $T_0 \left(\frac{P_0 + \rho_l g H}{P_0 + \rho_l g y} \right)^{\frac{2}{5}}$
 - $T_0 \left(\frac{P_0 + \rho_l g (H - y)}{P_0 + \rho_l g H} \right)^{\frac{2}{5}}$
 - $T_0 \left(\frac{P_0 + \rho_l g H}{P_0 + \rho_l g y} \right)^{\frac{3}{5}}$
 - $T_0 \left(\frac{P_0 + \rho_l g (H - y)}{P_0 + \rho_l g H} \right)^{\frac{3}{5}}$
- The buoyancy force acting on the gas bubble is (assume R is the universal gas constant).
 - $\rho_l n R g T_0 \frac{(P_0 + \rho_l g H)^{\frac{2}{5}}}{(P_0 + \rho_l g y)^{\frac{7}{5}}}$
 - $\frac{\rho_l n R g T_0}{(P_0 + \rho_l g H)^{\frac{2}{5}} (P_0 + \rho_l g (H - y))^{\frac{3}{5}}}$
 - $\rho_l n R g T_0 \frac{(P_0 + \rho_l g H)^{\frac{3}{5}}}{(P_0 + \rho_l g y)^{\frac{8}{5}}}$
 - $\frac{\rho_l n R g T_0}{(P_0 + \rho_l g H)^{\frac{3}{5}} (P_0 + \rho_l g (H - y))^{\frac{2}{5}}}$

Comprehension 4

A steel bolt of cross-sectional area $A_b = 5 \times 10^{-5} \text{ m}^2$ is passed through a cylindrical tube made of aluminium. The cross-sectional area of the tube material is $A_t = 10^{-4} \text{ m}^2$ and its length is $l = 50 \text{ cm}$. The bolt is just taut so that there is no stress in the bolt and the temperature of the assembly is increased through $\Delta T = 10 \text{ }^\circ\text{C}$. Given, coefficient of linear thermal expansion of steel, $\alpha_b = 10^{-5} \text{ }^\circ\text{C}^{-1}$.

Young's modulus of steel $Y_b = 2 \times 10^{11} \text{ Nm}^{-2}$.

Young's modulus of Al, $Y_t = 10^{11} \text{ Nm}^{-2}$, coefficient of linear thermal expansion of Al, $\alpha_t = 2 \times 10^{-5} \text{ }^\circ\text{C}^{-1}$. Based on the above facts, answer the following questions.

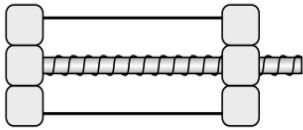

10. The compressive strain in tube is

- (A) 10^{-4} (B) 5×10^{-5}
(C) 2×10^{-3} (D) 10^{-6}

11. The compressive stress in tube is

- (A) $5 \times 10^6 \text{ Nm}^{-2}$ (B) 10^5 Nm^{-2}
(C) 10^8 Nm^{-2} (D) 10^3 Nm^{-2}

12. The tensile stress in bolt is

- (A) 10^4 Nm^{-2} (B) 10^7 Nm^{-2}
(C) $2 \times 10^8 \text{ Nm}^{-2}$ (D) 10^{10} Nm^{-2}

Comprehension 5

A fixed thermally conducting cylinder has a radius R and height L_0 . The cylinder is open at its bottom and has a small hole at its top. A piston of mass M is held at a distance L from the top surface, as shown in the figure. The atmospheric pressure is P_0 . Based on the above facts, answer the following questions.

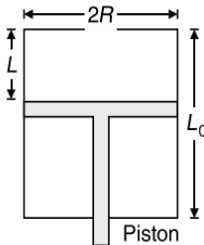

13. The piston is now pulled out slowly and held at a distance $2L$ from the top. The pressure in the cylinder between its top and piston will then be

- (A) P_0 (B) $\frac{P_0}{2}$
(C) $\frac{P_0}{2} + \frac{Mg}{\pi R^2}$ (D) $\frac{P_0}{2} - \frac{Mg}{\pi R^2}$

14. While the piston is at a distance $2L$ from the top, the hole at the top is sealed. The piston is then released, to a position where it can stay in equilibrium. In this condition, the distance of the piston from the top is

- (A) $\left(\frac{2P_0\pi R^2}{\pi R^2 P_0 + Mg}\right)(2L)$ (B) $\left(\frac{P_0\pi R^2 - Mg}{\pi R^2 P_0}\right)(2L)$
(C) $\left(\frac{P_0\pi R^2 + Mg}{\pi R^2 P_0}\right)(2L)$ (D) $\left(\frac{P_0\pi R^2}{\pi R^2 P_0 - Mg}\right)(2L)$

15. The piston is taken completely out of the cylinder. The hole at the top is sealed. A water tank is brought below the cylinder and put in a position so that the water surface in the tank is at the same level as the top of the cylinder as shown in the figure. The density of the water is ρ . In equilibrium, the height H of the water column in the cylinder satisfies

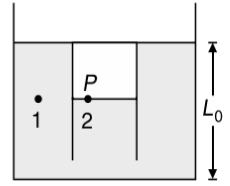

- (A) $\rho g(L_0 - H)^2 + P_0(L_0 - H) + L_0 P_0 = 0$
(B) $\rho g(L_0 - H)^2 - P_0(L_0 - H) - L_0 P_0 = 0$
(C) $\rho g(L_0 - H)^2 + P_0(L_0 - H) - L_0 P_0 = 0$
(D) $\rho g(L_0 - H)^2 - P_0(L_0 - H) + L_0 P_0 = 0$

Comprehension 6

Five rods of same material and same cross section are joined as shown. Lengths of rods ab , ad and bc are l , $2l$ and $3l$ respectively. Ends a and c are maintained at temperatures $200 \text{ }^\circ\text{C}$ and $0 \text{ }^\circ\text{C}$ respectively.

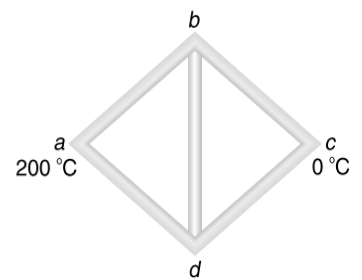

Based on the above facts, answer the following questions.

16. The length x of rod dc for which there will be no heat flow through rod bd is

- (A) $4l$ (B) $2l$
(C) $6l$ (D) $9l$

17. Then temperature of junction b or d is

- (A) $120 \text{ }^\circ\text{C}$ (B) $160 \text{ }^\circ\text{C}$
(C) $90 \text{ }^\circ\text{C}$ (D) $150 \text{ }^\circ\text{C}$

Comprehension 7

A certain amount of ice is supplied heat at a constant rate for 7 min. For the first one minute the temperature rises uniformly with time. Then it remains constant for the next 4 min and again the temperature rises at uniform rate for the last 2 min. Given that $c_{\text{ice}} = 0.5 \text{ cal g}^{-1} \text{ }^\circ\text{C}$, $L_{\text{ice}} = 80 \text{ cal g}^{-1}$. Based on the above facts, answer the following questions.

18. The initial temperature of ice is

- (A) $-10 \text{ }^\circ\text{C}$ (B) $-20 \text{ }^\circ\text{C}$
(C) $-30 \text{ }^\circ\text{C}$ (D) $-40 \text{ }^\circ\text{C}$

19. The final temperature of the ice, at the end of 7 min is

- (A) $20 \text{ }^\circ\text{C}$ (B) $30 \text{ }^\circ\text{C}$
(C) $40 \text{ }^\circ\text{C}$ (D) $50 \text{ }^\circ\text{C}$

Comprehension 8

A gaseous mixture enclosed in a vessel of volume V consists of one mole of a gas A with $\gamma = \left(\frac{C_p}{C_v}\right) = \frac{5}{3}$ and another gas B with $\gamma = \frac{7}{5}$ at a certain temperature T . The relative molar masses of the gases A and B are 4 and 32, respectively. The gases A and B do not react with each other and are assumed to be ideal. The

2.162 JEE Advanced Physics: Waves and Thermodynamics

gaseous mixture follows the equation $PV^{13/5} = \text{constant}$, in an adiabatic process. Based on the above facts, answer the following questions.

20. Number of moles of the gas B in the gaseous mixture is
 (A) 1 mole (B) 3 mole
 (C) 4 mole (D) 2 mole
21. The mixture is compressed adiabatically to $\frac{1}{5}$ of its initial volume V . The change in its adiabatic compressibility in

terms of the given quantities is (Given that $5^{13} = 10.48$).

- (A) $-0.025 \frac{V}{T}$ (B) $-0.050 \frac{V}{T}$
 (C) $-0.075 \frac{V}{T}$ (D) $-0.100 \frac{V}{T}$

Comprehension 9

In a cylindrical container of sufficiently large height, two easily moving pistons enclose certain amount of same ideal gas in two chambers as shown in Figure.

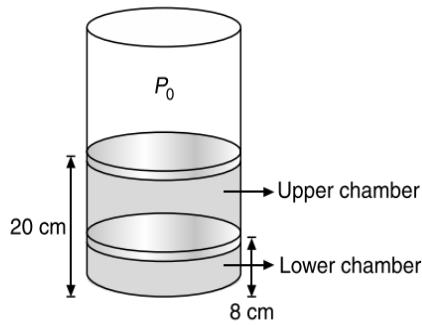

The upper piston is at a height 20 cm from the bottom and lower piston is at a height 8 cm from the bottom. The mass of each piston is m kg and cross sectional area of each piston is A m², where $\frac{mg}{A} = P_0$ and P_0 is the atmospheric pressure given by 1×10^5 Nm⁻². The cylindrical container and pistons are made of conducting material. Initially the temperature of gas is 27 °C and whole system is in equilibrium. Now if the upper piston is slowly lifted by 16 cm and held in that position with the help of some external force. As a result, the lower piston rises slowly by l cm. Based on the information give, answer the following questions.

22. The value of l is
 (A) 2 cm (B) 4 cm
 (C) 8 cm (D) 6 cm
23. The ratio of volume of gas in upper chamber to that of in lower chamber in final state is
 (A) 2:1 (B) 1:2
 (C) 4:1 (D) 1:4
24. The pressure of gas in lower chamber in final state is
 (A) 1.0×10^5 Nm⁻² (B) 2.0×10^5 Nm⁻²
 (C) 3.0×10^5 Nm⁻² (D) 4.0×10^5 Nm⁻²

Comprehension 10

A quantity of an ideal monatomic gas consists of n moles initially at temperature T_1 . The pressure and volume are then slowly doubled in such a manner so as to trace out a straight line passing through origin on a P - V diagram as shown. Based on the above facts, answer the following questions.

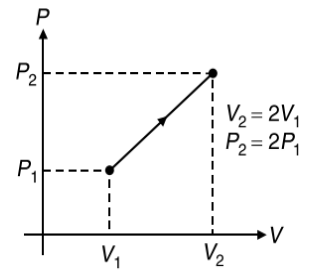

25. For this process, the ratio $\frac{W}{nRT_1}$ is equal to (where W is work done by the gas) is
 (A) 1.5 (B) 3
 (C) 4.5 (D) 6
26. For the same process, the ratio $\frac{Q}{nRT_1}$ is equal to (where Q is heat supplied to the gas) is
 (A) 1.5 (B) 3
 (C) 4.5 (D) 6
27. If C is defined as the average molar specific heat for the process, then $\frac{C}{R}$ has value
 (A) 1.5 (B) 2
 (C) 3 (D) 6

Comprehension 11

One mole of an ideal monatomic gas is taken round the cyclic process $ABCA$ as shown in figure.

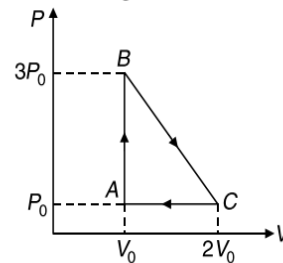

Based on the above facts, answer the following questions.

28. The work done in the complete cycle is
 (A) ZERO (B) P_0V_0 , by the system
 (C) $\frac{P_0V_0}{2}$, by the system (D) P_0V_0 , on the system
29. If dQ_{CA} is the heat absorbed/rejected by the gas in the path CA , then
 (A) $dQ_{CA} = \frac{5}{2}P_0V_0$, absorbed (B) $dQ_{CA} = \frac{3}{2}P_0V_0$, absorbed
 (C) $dQ_{CA} = \frac{5}{2}P_0V_0$, rejected (D) $dQ_{CA} = \frac{3}{2}P_0V_0$, rejected
30. If dQ_{AB} is the heat absorbed/rejected by the gas in the path AB , then
 (A) $dQ_{AB} = \frac{3}{2}P_0V_0$, absorbed (B) $dQ_{AB} = 3P_0V_0$, absorbed
 (C) $dQ_{AB} = \frac{3}{2}P_0V_0$, rejected (D) $dQ_{AB} = 3P_0V_0$, rejected

31. If d_{BC} is the heat absorbed/rejected by the gas in the path BC, then

- (A) $dQ_{BC} = \frac{3}{2}P_0V_0$, absorbed (B) $dQ_{BC} = \frac{1}{2}P_0V_0$, rejected
 (C) $dQ_{BC} = \frac{1}{2}P_0V_0$, absorbed (D) $dQ_{BC} = \frac{3}{2}P_0V_0$, rejected

32. The maximum temperature attained by the gas during the cycle is

- (A) $\frac{25}{8} \frac{P_0V_0}{R}$ (B) $\frac{3P_0V_0}{R}$
 (C) $\frac{8}{25} \frac{P_0V_0}{R}$ (D) $\frac{1}{3} \frac{P_0V_0}{R}$

Comprehension 12

Consider one mole of an ideal gas having $\gamma = \frac{C_p}{C_v}$ which expands

according to the law $P = \alpha V$ where P is the pressure, V is the volume and α is a constant. Assuming the initial volume of the gas to be V_0 and when expanded to a volume nV_0 , answer the following questions.

33. The work done by the gas is

- (A) $\frac{\alpha V_0^2}{2}(n^2 - 1)$ (B) $\alpha V_0^2(n^2 - 1)$
 (C) $\alpha V_0^2(1 - n^2)$ (D) $\frac{\alpha V_0^2}{2}(1 - n^2)$

34. The change in internal energy of gas is

- (A) $\frac{\alpha}{(1-\gamma)}V_0^2(n^2 - 1)$ (B) $\frac{\alpha}{(\gamma-1)}V_0^2(n^2 - 1)$
 (C) $\frac{\alpha}{2(1-\gamma)}V_0^2(n^2 - 1)$ (D) $\frac{\alpha}{2(\gamma-1)}V_0^2(n^2 - 1)$

35. The specific heat for the process is

- (A) $\left(\frac{\gamma-1}{\gamma+1}\right)\frac{R}{2}$ (B) $\left(\frac{\gamma+1}{\gamma-1}\right)\frac{R}{2}$
 (C) $\left(\frac{\gamma+1}{\gamma-1}\right)R$ (D) $\left(\frac{\gamma-1}{\gamma+1}\right)R$

Comprehension 13

In a thermodynamic process, it is observed that the internal energy of an ideal gas varies with pressure P and volume V as $U = 3PV$. If the gas expands from V_0 to $2V_0$ at a constant pressure P_0 . Based on the above facts, answer the following questions.

36. The heat absorbed by the gas in the process is

- (A) P_0V_0 (B) $2P_0V_0$
 (C) $3P_0V_0$ (D) $4P_0V_0$

37. The value of $\gamma \left(= \frac{C_p}{C_v} \right)$ for the given gas is

- (A) 1.33 (B) 1.4
 (C) 1.67 (D) 1.5

Comprehension 14

One mole of monatomic gas is taken through a cyclic process shown. If $T_A = 300$ K and the process AB is defined as $PT = \text{constant}$, then based on the above facts, answer the following questions.

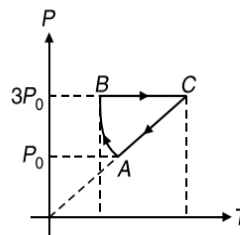

38. Work done in process AB is

- (A) $400R$ (B) $-400R$
 (C) $200R$ (D) $-300R$

39. The change in internal energy in process CA

- (A) $900R$ (B) $300R$
 (C) $-1200R$ (D) $-900R$

40. Heat transferred in the process BC is

- (A) $1000R$ (B) $500R$
 (C) $2000R$ (D) $1500R$

Comprehension 15

One mole of an ideal monatomic gas is taken around a cyclic process as shown. The processes AB, BC, CD and DA are isobaric, adiabatic, isochoric and isothermal respectively. It is known that $T_A = 4T_B$ and $V_A = (8\sqrt{2})V_D$. Based on the above facts, answer the following questions.

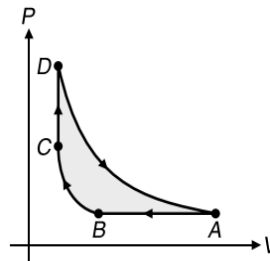

41. The temperature at state C is T_C , given by

- (A) $T_C = T_B$ (B) $T_C = 2T_B$
 (C) $T_C = 3T_B$ (D) None of these

42. The work done by gas during the cyclic process in one cycle is

- (A) $5.2RT_B$ (B) $4RT_B$
 (C) $3.2RT_B$ (D) None of these

43. Efficiency of cycle of the cyclic process is

- (A) 21% (B) 41%
 (C) 51% (D) None of these

Comprehension 16

The V - T graph for an ideal gas is shown in figure. Based on the information provided and a careful observation of the graph, answer the following questions.

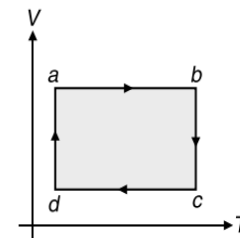

44. Work done by the gas in complete cyclic process $a \rightarrow b \rightarrow c \rightarrow d \rightarrow a$ is

- (A) ZERO (B) positive
 (C) negative (D) data is insufficient

45. Heat is supplied to the gas in process/es

- (A) da, ab and bc (B) da and ab only
 (C) da only (D) ab and bc only

Comprehension 17

An ideal gas undergoes a process in which $T = T_0 + aV^3$, where T_0 and a are positive constants and V is molar volume. Based on the information given, answer the following questions.

46. The volume at which the pressure attains a minimum value is

- (A) $\left(\frac{T_0}{2a}\right)^{\frac{1}{3}}$ (B) $\left(\frac{T_0}{3a}\right)^{\frac{1}{3}}$
 (C) $\left(\frac{a}{2T_0}\right)^{\frac{2}{3}}$ (D) $\left(\frac{a}{3T_0}\right)^{\frac{2}{3}}$

47. The minimum pressure attainable per mole of gas is

- (A) $\frac{3}{4}\left(a^{\frac{5}{3}}R^{\frac{2}{3}}T_0^{\frac{2}{3}}\right)2^{\frac{1}{3}}$ (B) $\frac{3R}{2}\left(3a^2T_0^2\right)^{\frac{1}{3}}$
 (C) $\frac{3}{2}\left(a^{\frac{1}{2}}R^{\frac{2}{3}}T_0^{\frac{3}{4}}\right)4^{\frac{1}{3}}$ (D) $\frac{3R}{2}\left(2aT_0^2\right)^{\frac{1}{3}}$

Comprehension 18

An ideal gas having initial pressure P , volume V and temperature T is allowed to expand adiabatically until its volume becomes $5.66V$ while its temperature falls to $\frac{T}{2}$.

Based on the above facts, answer the following questions.

48. The degrees of freedom possessed by the gas molecules is/are

- (A) 1 (B) 2
 (C) 3 (D) 5

49. The work done by the gas during expansion as a function of initial pressure P and volume V is

- (A) 2.31 PV (B) 1.23 PV
 (C) 3.21 PV (D) None of these seems to be correct

Comprehension 19

One mole of an ideal gas has an internal energy given by $U = U_0 + 2PV$, where P is the pressure and V the volume of the gas and U_0 is a constant. This gas undergoes the quasi-static cyclic process ABCD as shown in the U - V diagram. Based on the above facts, answer the following questions.

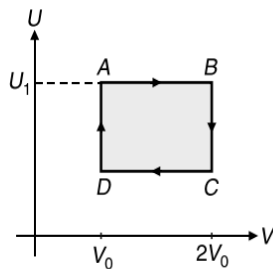

50. The molar heat capacity of the gas at constant pressure is

- (A) 2R (B) 3R
 (C) $\frac{5}{2}R$ (D) 4R

51. The work done by the ideal gas in the process AB is

- (A) ZERO (B) $\frac{U_1 - U_0}{2}$
 (C) $\frac{U_0 - U_1}{2}$ (D) $\frac{U_1 - U_0}{2} \log_e(2)$

52. Assuming that the gas consists of a mixture of two gases, the gas is

- (A) Monatomic
 (B) Diatomic
 (C) A mixture of mono and diatomic gases
 (D) A mixture of di- and tri-atomic gases

Comprehension 20

A non-conducting vessel containing n moles of a diatomic gas is fitted with a conducting piston. The cross-sectional area, thickness and thermal conductivity of piston are A , l and K respectively. The right side of piston is open to atmosphere at temperature T_0 . Heat is supplied to the gas by means of an electric heater at a constant rate q . Based on the above facts, answer the following questions.

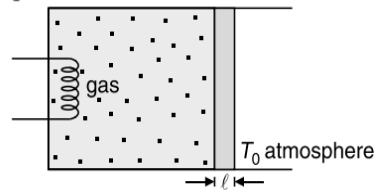

53. The temperature of gas as a function of time is

- (A) $T = T_0 + \frac{ql}{KA} \left(1 - e^{-\frac{2KA t}{7nRl}}\right)$
 (B) $T = T_0 + \frac{ql}{KA} \left(1 - e^{-\frac{7nRl}{2KA t}}\right)$
 (C) $T = T_0 + \frac{ql}{KA} \left(e^{-\frac{2KA t}{7nRl}}\right)$
 (D) None of these

54. The maximum temperature of gas is

- (A) $T_{\max} = T_0 + \frac{KA}{ql}$ (B) $T_{\max} = T_0 + \frac{ql}{KA}$
 (C) $T_{\max} = \frac{ql}{KA}$ (D) $T_{\max} = T_0 + \frac{ql}{KA} (1 - e)$

55. The ratio of the maximum volume to the minimum volume is

- (A) $1 + \frac{KAT_0}{ql}$ (B) $\frac{KAT_0}{ql}$
 (C) $\frac{ql}{KAT_0}$ (D) $1 + \frac{ql}{KAT_0}$

Comprehension 21

Two moles of an ideal monatomic gas is taken from a to c , via three paths $a \rightarrow b \rightarrow c$, $a \rightarrow c$ and $a \rightarrow d \rightarrow c$ as shown. Based on the above facts, answer the following questions.

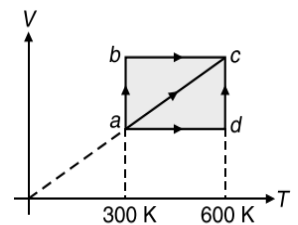

56. Work done by the gas in process $a \rightarrow c$ is

- (A) 1000R (B) 900R
 (C) 600R (D) 1500R

57. If work done by the gas in $a \rightarrow b \rightarrow c$ is W_1 , in $a \rightarrow c$ work done is W_2 and in $a \rightarrow d \rightarrow c$ work done is W_3 , then

- (A) $W_2 > W_3 > W_1$ (B) $W_1 > W_2 > W_3$
 (C) $W_2 > W_1 > W_3$ (D) $W_3 > W_2 > W_1$

Comprehension 22

Two moles of helium gas ($\gamma = \frac{5}{3}$) is initially at temperature 27°C and occupies a volume of 20 litre. The gas is first expanded at constant pressure until the volume is doubled. Then it undergoes an adiabatic change until the temperature returns to its initial value. Based on the above facts, answer the following questions.

58. The final volume of the gas is
 (A) 100 litre (B) 110 litre
 (C) 113 litre (D) 120 litre
59. The final pressure of the gas is
 (A) $3.4 \times 10^6 \text{ Nm}^{-2}$ (B) $4.4 \times 10^6 \text{ Nm}^{-2}$
 (C) $5.4 \times 10^6 \text{ Nm}^{-2}$ (D) $6.4 \times 10^6 \text{ Nm}^{-2}$
60. The work done by the gas is
 (A) 14259 J (B) 19452 J
 (C) 12954 J (D) 12459 J

Comprehension 23

In the situation shown in figure the spring of spring constant K is at its natural length. In both the chambers of the non-conducting vessel separated by a non-conducting piston, n moles of monoatomic gas is filled at temperature T . Heat is now supplied to the right chamber. It is observed that the temperature of the left chamber does not change and the piston is displaced by $\frac{L}{4}$. Based on the above facts, answer the following questions.

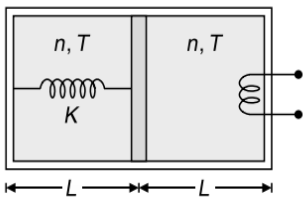

61. The change in temperature of the right chamber is
 (A) $2T + \frac{5KL^2}{16nR}$ (B) $\frac{T}{3} + \frac{KL^2}{16nR}$
 (C) $\frac{2T}{3} + \frac{5KL^2}{16nR}$ (D) $\frac{2T}{3} + \frac{5KL^2}{nR}$
62. The change in the internal energy of the right chamber is
 (A) $nRT + \frac{15KL^2}{32}$ (B) $nRT + \frac{KL^2}{32}$
 (C) $2nRT + 15KL^2$ (D) $3nRT + \frac{15KL^2}{32}$
63. The heat transferred into the system is
 (A) $2nRT + \frac{KL^2}{2}$ (B) $nRT + \frac{KL^2}{2}$
 (C) $3nRT + \frac{KL^2}{32}$ (D) $nRT + \frac{KL^2}{32}$

Comprehension 24

In a thermodynamic process, the temperature T varies with volume V as $T = T_0 + \alpha V^3$, where T_0 and α are constants. Based on the above facts, answer the following questions.

64. The volume at which the pressure is the minimum is
 (A) $\sqrt{\frac{T_0}{2\alpha}}$ (B) $\left(\frac{T_0}{3\alpha}\right)^{\frac{1}{3}}$
 (C) $\left(\frac{T_0}{2\alpha}\right)^{\frac{1}{3}}$ (D) $\left(\frac{\alpha}{2T_0}\right)^{\frac{2}{3}}$
65. Molar heat capacity of gas in the above process
 (A) $C_V + \frac{R}{3} + \frac{RT_0}{3\alpha V^3}$ (B) $C_V + \frac{RT_0}{3\alpha V^3}$
 (C) $C_V - \frac{R}{3} + \frac{RT_0}{3\alpha V^3}$ (D) None of these
66. The ratio of the minimum attainable pressure during process to $nRT_0^{\frac{2}{3}}\alpha^{\frac{1}{3}}$ is
 (A) $2^{\frac{1}{3}}$ (B) $\left(2^{\frac{1}{3}} + 2^{\frac{2}{3}}\right)$
 (C) $\left(2^{\frac{2}{3}} + 2^{\frac{4}{3}}\right)$ (D) $2^{\frac{2}{3}}$

Comprehension 25

Figure shows a radiant energy spectrum graph for a black body at a temperature T_0 . Based on the spectrum graph, answer the following questions.

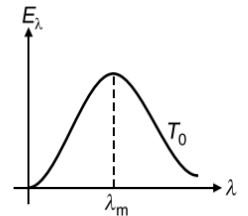

67. Select the correct statement.
 (A) The radiant energy is equally distributed among all the possible wavelengths
 (B) For a particular wavelength the spectral intensity is minimum
 (C) The area under the curve is equal to the total intensity (energy per unit area per second) radiated by the body at that temperature
 (D) None of these
68. If the temperature of the body is raised to a higher temperature T , then select the correct statement.
 (A) The intensity of radiation for every wavelength decreases
 (B) The maximum intensity occurs at a greater wavelength
 (C) The area under the graph decreases
 (D) The area under the graph is proportional to the fourth power of temperature
69. Identify the graph which correctly represents the spectral intensity versus wavelength graph at two temperatures T and T_0 ($T > T_0$).

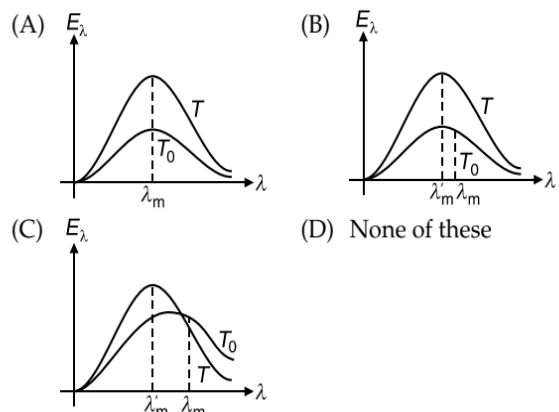

Comprehension 26

Two perfect gases at absolute temperatures T_1 and T_2 are mixed. There is no loss of energy. The masses of the molecules are m_1 and m_2 . The number of molecules in the two gases are n_1 and n_2 . Based on the above facts, answer the following questions.

70. What is the average kinetic energy of all the molecules of two gases before mixing?

- (A) $\frac{1}{2}k(n_1T_1 + n_2T_2)$ (B) $\frac{3}{2}k(n_1T_1 + n_2T_2)$
 (C) $\frac{5}{2}k(n_1T_1 + n_2T_2)$ (D) $\frac{7}{2}k(n_1T_1 + n_2T_2)$

71. If T is the temperature of the mixture, then the average kinetic energy of the two gases after mixing is

- (A) $\frac{1}{2}k(n_1 + n_2)T$ (B) $\frac{3}{2}k(n_1 + n_2)T$
 (C) $\frac{5}{2}k(n_1 + n_2)T$ (D) $\frac{7}{2}k(n_1 + n_2)T$

72. The temperature T of the mixture is

- (A) $n_1T_1 + n_2T_2$ (B) $\frac{n_1T_1}{n_1 + n_2}$
 (C) $\frac{n_2T_2}{n_1 + n_2}$ (D) $\frac{n_1T_1 + n_2T_2}{n_1 + n_2}$

Comprehension 27

An ideal diatomic gas having $C_V = \frac{5R}{2}$ occupies a volume V_0 at a pressure P_0 . The gas undergoes a process in which the pressure is directly proportional to the volume. At the end of the process,

the rms speed of the gas molecules gets doubled from its initial value. Based on the above facts, answer the following questions.

73. The molar heat capacity of the gas in the given process is

- (A) $3R$ (B) $3.5R$
 (C) $4R$ (D) $2.5R$

74. The heat supplied to the gas in the given process is

- (A) $7P_0V_0$ (B) $8P_0V_0$
 (C) $9P_0V_0$ (D) $10P_0V_0$

Comprehension 28

Two moles of helium gas undergo a cyclic process as shown in figure. Assuming the gas to be ideal, calculate the following quantities in this process. Based on the above facts, answer the following questions.

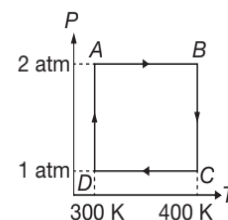

75. The net change in internal energy for the complete process is

- (A) 4608 J (B) 6408 J
 (C) ZERO (D) None of these

76. If dQ and dW indicate the total work done in the complete cyclic process, then

- (A) $dQ = 8064 \text{ J}$, $dW = 1152 \text{ J}$ (B) $dQ = dW = 8064 \text{ J}$
 (C) $dQ = 1152 \text{ J}$, $dW = 8064 \text{ J}$ (D) $dQ = dW = 1152 \text{ J}$

77. If dS denotes the total entropy in the complete cyclic process, then

- (A) $dS = 3.84 \text{ JK}^{-1}$ (B) $dS = 2.88 \text{ JK}^{-1}$
 (C) $dS = 3.29 \text{ JK}^{-1}$ (D) $dS = \text{zero}$

MATRIX MATCH/COLUMN MATCH TYPE QUESTIONS

Each question in this section contains statements given in two columns, which have to be matched. The statements in COLUMN-I are labelled A, B, C and D, while the statements in COLUMN-II are labelled p, q, r, s (and t). Any given statement in COLUMN-I can have correct matching with **ONE OR MORE** statement(s) in COLUMN-II. The appropriate bubbles corresponding to the answers to these questions have to be darkened as illustrated in the following examples:

If the correct matches are $A \rightarrow p, s$ and t ; $B \rightarrow q$ and r ; $C \rightarrow p$ and q ; and $D \rightarrow s$ and t ; then the correct darkening of bubbles will look like the following:

	p	q	r	s	t
A	<input checked="" type="checkbox"/>	<input checked="" type="checkbox"/>	<input checked="" type="checkbox"/>	<input checked="" type="checkbox"/>	<input checked="" type="checkbox"/>
B	<input checked="" type="checkbox"/>	<input checked="" type="checkbox"/>	<input checked="" type="checkbox"/>	<input checked="" type="checkbox"/>	<input checked="" type="checkbox"/>
C	<input checked="" type="checkbox"/>	<input checked="" type="checkbox"/>	<input checked="" type="checkbox"/>	<input checked="" type="checkbox"/>	<input checked="" type="checkbox"/>
D	<input checked="" type="checkbox"/>	<input checked="" type="checkbox"/>	<input checked="" type="checkbox"/>	<input checked="" type="checkbox"/>	<input checked="" type="checkbox"/>

1. Match the processes in COLUMN-I to their property(ies) in COLUMN-II.

COLUMN-I	COLUMN-II
(A) Cyclic process	(p) $\Delta U < 0$
(B) Isobaric process	(q) $Q = W$
(C) Isochoric process	(r) $W = nR\Delta T$
(D) Adiabatic expansion	(s) $Q = \Delta U$
	(t) $\Delta U = 0$

2. The density (ρ) vs temperature (T) graph for a cyclic process is shown in figure, match the quantities in COLUMN-I to their matches in COLUMN-II.

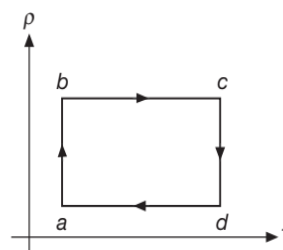

COLUMN-I	COLUMN-II
(A) Process $a \rightarrow b$	(p) P increasing
(B) Process $b \rightarrow c$	(q) P decreasing
(C) Process $c \rightarrow d$	(r) Isochoric process
(D) Process $d \rightarrow a$	(s) $\Delta U = 0$

3. Match the following.

COLUMN-I	COLUMN-II
(A) Work done by an ideal gas in a closed system	(p) Path dependent
(B) Internal energy of an ideal gas in a closed system	(q) State function
(C) Molar heat capacity of an ideal gas in a closed system	(r) May be constant (other than zero)
(D) Heat absorbed or rejected by an ideal gas in a closed system.	(s) May be zero

4. For one mole of a monatomic gas, match the following.

COLUMN-I	COLUMN-II
(A) Isothermal Bulk modulus	(p) $-\frac{RT}{V^2}$
(B) Adiabatic Bulk modulus	(q) $-\frac{5P}{3V}$
(C) Slope of P - V graph in an Isothermal process	(r) $\frac{RT}{V}$
(D) Slope of P - V graph in an Adiabatic process	(s) $\frac{5RT}{3V}$ (t) $\frac{4RT}{V}$

5. Match the physical quantities in COLUMN-I to their dimensional formula in COLUMN-II.

COLUMN-I	COLUMN-II
(A) Specific heat	(p) $MLT^{-3}K^{-1}$
(B) Coefficient of thermal conductivity	(q) $MT^{-3}K^{-4}$
(C) Boltzmann constant	(r) $L^2T^{-2}K^{-1}$
(D) Stefan's constant	(s) $ML^2T^{-2}K^{-1}$

6. With reference to the following P - V diagram, match the following quantities.

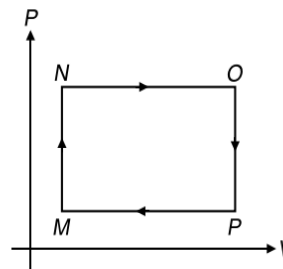

COLUMN-I	COLUMN-II
(A) Process MN	(p) $W = 0$
(B) Process NO	(q) $W < 0$
(C) Process OP	(r) $W > 0$
(D) Process PM	(s) $\Delta U > 0$ (t) $\Delta U < 0$

7. Match the following.

COLUMN-I	COLUMN-II
(A) $\frac{R}{1-\gamma}(T_f - T_i)$	(p) Change in internal energy of an Isothermal process.
(B) ZERO	(q) Molar specific heat of an Adiabatic process.
(C) $R(T_f - T_i)$	(r) Internal energy of n mole of gas sample.
(D) $\frac{PV}{\gamma-1}$	(s) Work done in an Isobaric process carried on one mole of gas. (t) Work done in an Isochoric process. (u) Work done in an Adiabatic process carried on one mole of gas.

8. Match the following

COLUMN-I	COLUMN-II
(A) Temperature of a gas	(p) Internal energy increases
(B) Work done by the gas	(q) Intermolecular force decreases
(C) Thermal expansion	(r) Path function
(D) Mechanical compression.	(s) State function

2.168 JEE Advanced Physics: Waves and Thermodynamics

9. An ideal monatomic gas is taken through one of the following reversible processes expressed by the equation in **COLUMN-I**. Match the molar heat capacity of the gas, expressed in multiples of R , in **COLUMN-II** with the appropriate process.

COLUMN-I	COLUMN-II
(A) $PV^{5/3} = \text{constant}$	(p) $\frac{5R}{2}$
(B) $TV^2 = \text{constant}$	(q) $\frac{3R}{2}$
(C) $V = \text{constant}$	(r) R
(D) $P = \text{constant}$	(s) ZERO

10. An ideal gas is taken along the reversible processes as shown in the Figure.

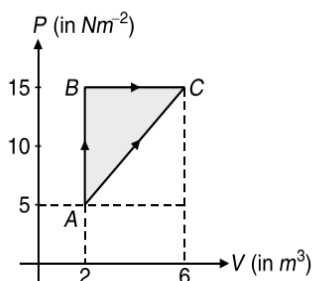

COLUMN-I	COLUMN-II
(A) For process $B \rightarrow C$	(p) $\Delta Q > 0$
(B) For process $A \rightarrow B$	(q) $\Delta W > 0$
(C) For process $A \rightarrow B \rightarrow C$	(r) $\Delta U > 0$
(D) For process $A \rightarrow C$	(s) $\Delta W = 0$

11. Three liquids A , B and C having masses m , $2m$ and $3m$, have same gram specific heat and have temperatures 20°C , 40°C and 60°C respectively. Temperature of the mixture when

COLUMN-I	COLUMN-II
(A) A and B are mixed	(p) 35°C
(B) A and C are mixed	(q) 52°C
(C) B and C are mixed	(r) 50°C
(D) A , B and C all three are mixed	(s) 33.3°C
	(t) 46.67°C

INTEGER/NUMERICAL ANSWER TYPE QUESTIONS

In this section, the answer to each question is a numerical value obtained after doing series of calculations based on the data given in the question(s).

1. An ice cube of mass 0.1 kg at 0°C is placed in an isolated container which is at 227°C . The specific heat c of the container varies with temperature T according to the empirical relation $c = A + BT$, where $A = 100\text{ cal kg}^{-1}\text{K}^{-1}$ and $B = 2 \times 10^{-2}\text{ cal kg}^{-1}\text{K}^{-2}$. If the final temperature of the container is 27°C , determine the mass of the container, in gram.
(Latent heat of fusion for water $= 8 \times 10^4\text{ cal kg}^{-1}$, specific heat of water $= 10^3\text{ cal kg}^{-1}\text{K}^{-1}$).

2. Three rods of material x and three rods of material y are connected as shown in figure. All the rods are of identical length and cross sectional area. If the end A is maintained at 60°C and the junction E at 10°C , calculate temperature of junctions B , C and D , in $^\circ\text{C}$. The thermal conductivity of x is $0.92\text{ cal cm}^{-1}\text{s}^{-1}(\text{}^\circ\text{C})^{-1}$ and that of y is $0.46\text{ cal cm}^{-1}\text{s}^{-1}(\text{}^\circ\text{C})^{-1}$.

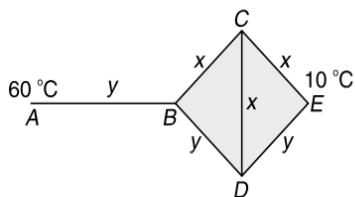

3. Calculate the work done on the gas or by the gas, in joule, when one mole of a perfect gas is compressed adiabatically. The initial pressure and volume of the gas are 10^5 Nm^{-2} and

6 litres respectively. The final volume of the gas is 2 litres molar specific heat of the gas at constant volume is $\frac{3R}{2}$.

4. An ideal monatomic gas is confined by a spring loaded massless piston of cross-section $8 \times 10^{-3}\text{ m}^2$. Initially, the gas is at 300 K and occupies a volume of $2.4 \times 10^{-3}\text{ m}^3$ and the spring is in its relaxed state. The gas is heated by an electric heater until the piston moves out slowly without friction by 0.1 m . Calculate
(a) the final temperature of the gas, in kelvin.
(b) the heat supplied by the heater, in joule.

The force constant of the spring is 8000 Nm^{-1} , atmospheric pressure is $1 \times 10^5\text{ Nm}^{-2}$. The cylinder and the piston are thermally insulated.

5. A spherical shell A emits like black body. It is kept in vacuum and isolated from all radiators. Its temperature in steady state is maintained 1000 K by some internal mechanism which gives it a constant power. Now this shell is enveloped by another shell B of almost same radius and emits like black body. Find the temperature of both shells, in kelvin, in the new steady state. Assume that internal mechanism of shell A produces the same power in the later case also. Given that, $(1.19)^4 = 2$.

6. In the construction of a flyover, steel girders of length 12 m are used to place one after another. How much gap, in mm, should be left between the two at their junction so that in summers when peak temperature is about 48 °C, there should not be any compression. Given that the construction is done in peak winters when temperature is 18 °C. Given that the coefficient of linear expansion of steel is $1.1 \times 10^{-5} \text{ }^\circ\text{C}^{-1}$.
7. Figure shows a cyclic process performed on one mole of an ideal gas. A total of 1000 J of heat is withdrawn from the gas in a complete cycle. Find the work done on/by the gas, in joule, during the process $B \rightarrow C$. Given $R = 8.3 \text{ J mol}^{-1} \text{ K}^{-1}$.

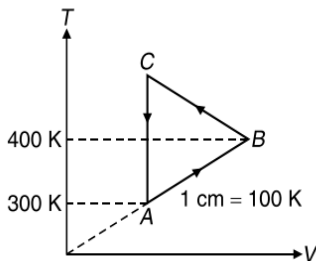

8. A pendulum gives correct time at 32 °C at a place where $x = 9.8 \text{ ms}^{-2}$. The pendulum consists of a light steel rod connected to a heavy ball. If it is taken to a different place where $g = 9.788 \text{ ms}^{-2}$. At what temperature, in °C, will it give correct time? The coefficient of linear expansion of steel is $12 \times 10^{-6} \text{ }^\circ\text{C}^{-1}$.
9. Two moles of helium gas undergo a cyclic process as shown in figure. Assuming the gas to be ideal, calculate the following quantities in this process, in calorie.
- The net change in the heat energy.
 - The net work done.
 - The net change in internal energy.

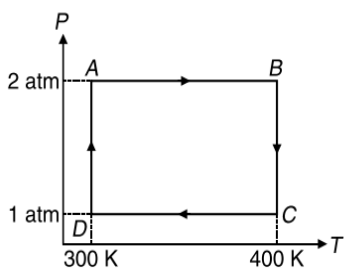

Given that $R = 2 \text{ cal mol}^{-1} \text{ K}^{-1}$ and $\log_e(2) = 0.7$.

10. A steel rod is clamped between two rigid supports at 20 °C. If the temperature of rod increases to 50 °C, the strain developed in the rod due to this is $x \times 10^{-5}$. Calculate x . Given that the coefficient of linear expansion of steel is $1.2 \times 10^{-5} \text{ }^\circ\text{C}^{-1}$.
11. A hollow sphere of glass whose external and internal radii are 11 cm and 9 cm respectively is completely filled with ice at 0 °C and placed in a bath of boiling water. How long, in seconds, will it take for the ice to melt completely? Given that density of ice is 0.9 g cm^{-3} , latent heat of fusion of ice is 80 cal g^{-1} and thermal conductivity of glass is $0.002 \text{ cal cm}^{-1} \text{ s}^{-1} \text{ }^\circ\text{C}^{-1}$.

12. One mole of an ideal monatomic gas undergoes the process $P = \alpha\sqrt{T}$, where α is a positive constant.
- The work done by the gas if its temperature increases by 50 K is $*R$.
 - The molar specific heat of the gas is $*R$.
- where $*$ in both (a) and (b) is not readable. Find the value of $*$ for both (a) and (b).
13. A bar with a crack at its centre buckles as a result of temperature rise of 32 °C. If the fixed distance L_0 is 4 m and the coefficient of linear expansion of the bar is $25 \times 10^{-6} \text{ (}^\circ\text{C)}^{-1}$ find the rise x of the centre, in mm, to the nearest two digit integer.

14. A horizontal cylindrical container of length 30 cm is partitioned by a tight-fitting separator. The separator is diathermic but conducts heat very slowly. Initially the separator is in the state shown in Figure.

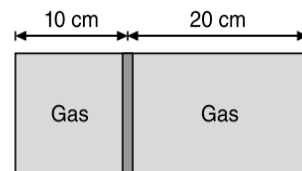

The temperature of left part of cylinder is 100 K and that on right part is 400 K. Initially the separator is in equilibrium. It is observed that when heat is conducted from right to left part, separator displaces to the right. Calculate the displacement of separator, in centimetre, after a long time when gases in the parts of cylinder are in thermal equilibrium.

15. A cube of coefficient of linear expansion α_s is floating in a bath containing a liquid of coefficient of volume expansion γ_l . When the temperature is raised by ΔT , the depth upto which the cube is submerged in the liquid remains the same. Find the ratio $\frac{\gamma_l}{\alpha_s}$.
16. Calculate the temperature (in kelvin) of the helium gas so that the rms speed of helium atoms becomes equal to escape speed from the earth's surface.
17. One mole of oxygen undergoes a cyclic process in which volume of the gas change 10 times within the cycle, as shown in the figure. Process: AB and CD are adiabatic. Find the efficiency of the process, in percent. Take $(10)^{0.4} = 2.5$.

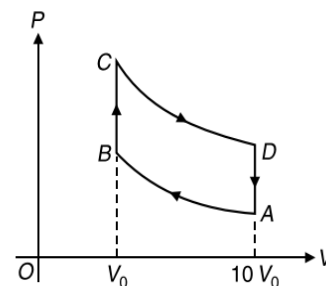

18. A black plane surface at a constant high temperature T_1 is parallel to another black plane surface at a constant lower temperature T_2 . Between the plates is vacuum.

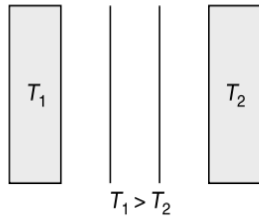
2.170 JEE Advanced Physics: Waves and Thermodynamics

In order to reduce the heat flow due to radiation, a heat shield consisting of two thin black plates, thermally isolated from each other is placed between the warm and the cold surfaces and parallel to these. After sometime stationary conditions are obtained. The stationary heat flow reduces, due to the presence of the heat shield by a factor of $f = \frac{1}{x}$ where $1 \leq x \leq 11$. Find x . Neglect the effects due to finite size of the surfaces.

19. Two cylinders A and B fitted with pistons contain equal amounts of an ideal diatomic gas at 300 K. The piston of A is free to move while that of B is held fixed. The same amount of heat is given to the gas in each cylinder. If the rise in temperature of the gas in A is 30 K, then calculate the rise in temperature of the gas in B in kelvin.
20. The apparatus shown in figure consists of four glass columns connected by horizontal sections. The height of two central columns B and C are 49 cm each. The two outer columns A and D are open to the atmosphere. A and C are maintained at a temperature of 95 °C while the columns B and D are maintained at 5 °C. The height of the liquid in A and D measured from the base line are 52.8 cm and 51 cm respectively. The coefficient of volume expansion of the liquid is $x \times 10^{-4} (\text{°C})^{-1}$. Find x .

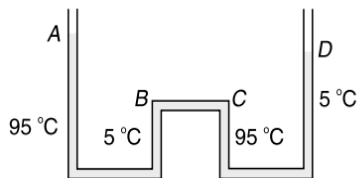

21. An ideal gas is enclosed in a cylinder with a movable piston on top. The piston has mass of 8000 g and an area of 5 cm² and is free to slide up and down, keeping the pressure of the gas constant. How much work is done, in joule, as the temperature of 0.2 mol gas is raised from 200 °C to 300 °C. Given $R = 8.3 \text{ Jmol}^{-1}\text{K}^{-1}$.
22. One end of a copper rod of length 1 m and area of cross section $4 \times 10^{-4} \text{ m}^2$ is maintained at 100 °C. At the other end of the rod ice is kept at 0 °C. Neglecting the loss of heat from the surroundings find the mass of ice, in gram, melted in 1 hr. Given $K_{Cu} = 401 \text{ Wm}^{-1}\text{K}^{-1}$ and $L_f = 3.35 \times 10^5 \text{ Jkg}^{-1}$.
23. A steel rod of cross-sectional area $2 \times 10^{-6} \text{ m}^2$ is fixed between two vertical walls as shown in Figure.

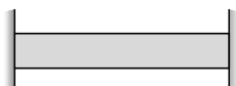

Initially at 20 °C, there is no force between the ends of the rod and the walls. Find the force which the rod will exert on

walls at 100 °C. Given that the coefficient of linear expansion of steel is $1.2 \times 10^{-5} \text{ °C}^{-1}$ and its Young's modulus is $2 \times 10^{11} \text{ Nm}^{-2}$.

24. A solid body floats in a liquid at a temperature $t = 50 \text{ °C}$ being completely submerged in it. What percentage of the volume of the body is submerged in the liquid after it is cooled to $t_0 = 0 \text{ °C}$, if the coefficient of cubic expansion for the solid is $\gamma_s = 0.3 \times 10^{-5} \text{ °C}^{-1}$ and of the liquid $\gamma_l = 8 \times 10^{-5} \text{ °C}^{-1}$.
25. An ideal gas having initial pressure P , volume V and temperature T is allowed to expand adiabatically until its volume becomes $5.66 V$ while its temperature falls to $\frac{T}{2}$. Calculate the degrees of freedom of the gas molecules. Given $\log_e(5.66) = 1.73$ $\log_e(2) = 0.70$
26. Calculate the work done by one kilomole of an ideal gas, in mega joule, in reversibly traversing the cycle shown in figure, ten times. Indicate the direction of traversal around the cycle if the net work is done by the gas.

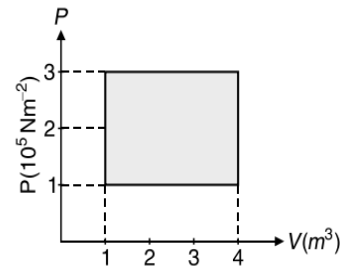

27. The temperature of 100 g of water is to be raised from 24 °C to 90 °C by adding steam to it. Calculate the mass of the steam, in gram, required for this purpose.
28. One gram of water (volume 1 cc) becomes 1671 cc of steam when boiled at a pressure of one atm. The latent heat of vaporisation of water is 540 calg⁻¹. Compute the external work done and increase in internal energy, in calorie. (1 atm = 10⁵ Nm⁻²).
29. The piston cylinder arrangement shown contains a diatomic gas at temperature 300 K. The cross-sectional area of the cylinder is 1 m². Initially the height of the piston above the base of the cylinder is 1 m. The temperature is now raised to 400 K at constant pressure. Find the new height of the piston above the base of the cylinder. If the piston is now brought back to its original height without any heat loss, find the new equilibrium temperature of the gas, in kelvin. Given that $\left(\frac{4}{3}\right)^{0.4} = 1.12$.

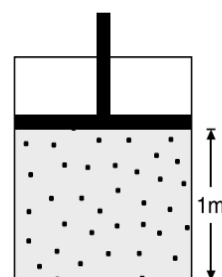

30. A pitcher contains 10 kg of water at 20 °C. Water comes to its outer surface through its porous walls and gets evaporated. The latent heat required for evaporation is taken from the water inside the pitcher and hence the water inside the pitcher gets cooled down. If the rate of evaporation of water is 0.2 gs^{-1} , calculate the approximate time (in second) in which temperature of water inside the pitcher drops to 15 °C. Given that the specific heat of water is $4200 \text{ Jkg}^{-1}\text{°C}^{-1}$ and latent heat of vaporisation of water is $2.27 \times 10^6 \text{ Jkg}^{-1}$.
31. An ideal diatomic gas undergoes a process in which its internal energy relates to the volume as $U = \alpha\sqrt{V}$, where α is a constant.
- (a) The molar specific heat of the gas is $\frac{*R}{2}$, where * is not readable. Find *.
- (b) Find the work performed by the gas, in joule, to increase its internal energy by 100 J.
32. A body cools in 10 minutes from 60 °C to 40 °C. What will be its temperature, in °C, after next 10 minutes? The temperature of the surroundings is 10 °C.
33. A ring shaped tube contains equal masses of two ideal gases of molar masses $M_1 = 32$ and $M_2 = 28$ respectively separated by one fixed partition PQ and another freely movable stopper RS as shown in Figure.

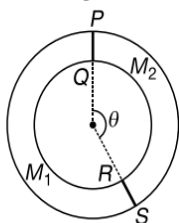

If temperature in the ring is same everywhere, then calculate the angle θ in degree.

34. A metal ball at 40 °C is dropped from a height of 6 km. The ball is heated due to the air resistance and it completely melts before reaching the ground. The molten substance falls slowly on the ground. Calculate the latent heat of fusion of metal, in kJkg^{-1} . Specific heat of lead is $125 \text{ Jkg}^{-1}\text{°C}^{-1}$, melting point of metal is 200 °C and $g = 10 \text{ ms}^{-2}$.
35. A monatomic ideal gas of two moles is taken through a cyclic process starting from A as shown in the figure. The volume ratios are $\frac{V_B}{V_A} = 2$ and $\frac{V_D}{V_A} = 4$. If the temperature T_A at A is 27 °C. Calculate

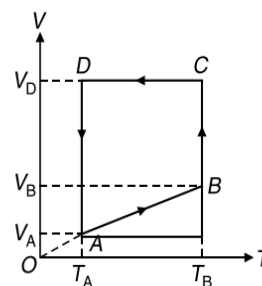

- (a) the temperature of the gas at point B , in kelvin.
- (b) heat absorbed or released by the gas in each process, in calorie.
- (c) the total work done by the gas during the complete cycle, in calorie.

Given that $\log_e(2) = 0.7$ and $R = 2 \text{ calmol}^{-1}\text{K}^{-1}$.

ARCHIVE: JEE MAIN

1. [Online September 2020]
A gas mixture consists of 3 mole of oxygen and 5 mole of argon at temperature T . Assuming the gases to be ideal and the oxygen bond to be rigid, the total internal energy (in units of RT) of the mixture is
- (A) 11 (B) 15
(C) 20 (D) 13
2. [Online September 2020]
An ideal gas in a closed container is slowly heated. As its temperature increases, which of the following statements are true?
- (1) the mean free path of the molecules decreases.
(2) the mean collision time between the molecules decreases.
(3) the mean free path remains unchanged.
(4) the mean collision time remains unchanged
- (A) (3) and (4) (B) (1) and (2)
(C) (1) and (4) (D) (2) and (3)
3. [Online September 2020]
When the temperature of a metal wire is increased from 0 °C to 10 °C, its length increases by 0.02%. The percentage change in its mass density will be closest to

- (A) 0.008 (B) 0.06
(C) 0.8 (D) 2.3

4. [Online September 2020]
A bakelite beaker has volume capacity of 500 cc at 30 °C. When it is partially filled with V_m volume (at 30°) of mercury, it is found that the unfilled volume of the beaker remains constant as temperature is varied. If $\gamma_{(\text{beaker})} = 6 \times 10^{-6} \text{ C}^{-1}$ and $\gamma_{(\text{mercury})} = 1.5 \times 10^{-4} \text{ °C}^{-1}$, where γ is the coefficient of volume expansion, then V_m (in cc) is close to _____.
5. [Online September 2020]
To raise the temperature of a certain mass of gas by 50 °C at a constant pressure, 160 calorie of heat is required. When the same mass of gas is cooled by 100 °C at constant volume, 240 calorie of heat is released. How many degrees of freedom does each molecule of this gas have (assume gas to be ideal)?
- (A) 5 (B) 3
(C) 6 (D) 7
6. [Online September 2020]
A calorimeter of water equivalent 20 g contains 180 g of water at 25 °C. m gram of steam at 100 °C is mixed in it will the temperature of the mixture is 31 °C. The value of m is

2.172 JEE Advanced Physics: Waves and Thermodynamics

close to (Latent heat of water is 540 calg^{-1} , specific heat of water $1 \text{ calg}^{-1}\text{C}^{-1}$)

- (A) 2.6 (B) 2
(C) 4 (D) 3.2

7. [Online September 2020]

Match the C_p/C_v ratio for ideal gases with different type of molecules.

Molecular Type	C_p/C_v
(A) Monoatomic	(p) 7/5
(B) Diatomic rigid molecules	(q) 9/7
(C) Diatomic non-rigid molecules	(r) 4/3
(D) Triatomic rigid molecules	(s) 5/3

- (A) A \rightarrow (s), B \rightarrow (p), C \rightarrow (q), D \rightarrow (r)
 (B) A \rightarrow (s), B \rightarrow (q), C \rightarrow (p), D \rightarrow (r)
 (C) A \rightarrow (r), B \rightarrow (s), C \rightarrow (q), D \rightarrow (p)
 (D) A \rightarrow (q), B \rightarrow (r), C \rightarrow (p), D \rightarrow (s)

8. [Online September 2020]

The specific heat of water is $4200 \text{ Jkg}^{-1}\text{K}^{-1}$ and the latent heat of ice is $3.4 \times 10^5 \text{ Jkg}^{-1}$. 100 g of ice at 0°C is placed in 200 g of water at 25°C . The amount of ice that will melt as the temperature of water reaches 0°C is close to (in gram)

- (A) 61.7 (B) 63.8
(C) 69.3 (D) 64.6

9. [Online September 2020]

A closed vessel contains 0.1 mole of a monoatomic ideal gas at 200 K. If 0.05 mole of the same gas at 400 K is added to it, the final equilibrium temperature (in K) of the gas in the vessel will be close to _____.

10. [Online September 2020]

The change in the magnitude of the volume of an ideal gas when a small additional pressure ΔP is applied at a constant temperature, is the same as the change when the temperature is reduced by a small quantity ΔT at constant pressure. The initial temperature and pressure of the gas were 300K and 2 atm respectively. If $|\Delta T| = C|\Delta P|$ then value of C in K/atm is _____.

11. [Online September 2020]

A bullet of mass 5 g, travelling with a speed of 210 ms^{-1} , strikes a fixed wooden target. One half of its kinetic energy is converted into heat in the bullet while the other half is converted into heat in the wood. The rise of temperature of bullet if specific heat of its material is $0.030 \text{ calg}^{-1}\text{C}^{-1}$ and $1 \text{ cal} = 4.2 \times 10^7 \text{ erg}$ is close to

- (A) 83.3°C (B) 87.5°C
(C) 119.2°C (D) 38.4°C

12. [Online September 2020]

Number of molecules in a volume of 4 cm^3 of a perfect monatomic gas at some temperature T and at a pressure of 2 cm of mercury is close to

(Given, mean kinetic energy of a molecule at T is $4 \times 10^{-14} \text{ erg}$, $g = 980 \text{ cms}^{-2}$, density of mercury is 13.6 gcm^{-3})

- (A) 5.8×10^{18} (B) 5.8×10^{16}
(C) 4.0×10^{18} (D) 4.0×10^{16}

13. [Online September 2020]

Two different wires having lengths L_1 and L_2 , and respective temperature coefficient of linear expansion α_1 and α_2 , are joined end-to-end. Then the effective temperature coefficient of linear expansion is

- (A) $\frac{4\alpha_1\alpha_2}{\alpha_1 + \alpha_2} \frac{L_2L_1}{(L_2 + L_1)^2}$ (B) $2\sqrt{\alpha_1\alpha_2}$
(C) $\frac{\alpha_1 + \alpha_2}{2}$ (D) $\frac{\alpha_1 + L_1 + \alpha_2L_2}{L_1 + L_2}$

14. [Online September 2020]

Nitrogen gas is at 300°C temperature. The temperature (in K) at which the rms speed of a H_2 molecule would be equal to the rms speed of a nitrogen molecule, is _____.
(Molar mass of N_2 gas 28 g)

15. [Online September 2020]

Molecules of an ideal gas are known to have three translational degrees of freedom and two rotational degrees of freedom. The gas is maintained at a temperature of T . The total internal energy, U of a mole of this gas, and the value of $\gamma \left(= \frac{C_p}{C_v} \right)$ given, respectively, by

- (A) $U = \frac{5}{2}RT$ and $\gamma = \frac{6}{5}$ (B) $U = 5RT$ and $\gamma = \frac{7}{5}$
(C) $U = 5RT$ and $\gamma = \frac{6}{5}$ (D) $U = \frac{5}{2}RT$ and $\gamma = \frac{7}{5}$

16. [Online September 2020]

Initially a gas of diatomic molecules is contained in a cylinder of volume V_1 at a pressure P_1 and temperature 250 K. Assuming that 25% of the molecules get dissociated causing a change in number of moles. The pressure of the resulting gas at temperature 2000 K, when contained in a volume $2V_1$ is given by P_2 . The ratio $\frac{P_2}{P_1}$ is

17. [Online September 2020]

In a dilute gas at pressure P and temperature T , the mean time between successive collisions of a molecule varies with T as

- (A) \sqrt{T} (B) $\frac{1}{T}$
(C) $\frac{1}{\sqrt{T}}$ (D) T

18. [Online September 2020]

A heat engine is involved with exchange of heat of 1915 J, -40 J , $+125 \text{ J}$ and $Q \text{ J}$, during one cycle achieving an efficiency of 50.0%. The value of Q is

- (A) 640 J (B) 400 J
(C) 980 J (D) 40 J

19. [Online September 2020]

A balloon filled with helium (32 °C and 1.7 atm.) bursts. Immediately afterwards the expansion of helium can be considered as

- (A) irreversible isothermal (B) irreversible adiabatic
(C) reversible adiabatic (D) reversible isothermal

20. [Online September 2020]

If minimum possible work is done by a refrigerator in converting 100 g of water at 0 °C to ice, how much heat (in calories) is released to the surrounding at temperature 27 °C (Latent heat of ice is 80 calg⁻¹) to the nearest integer is _____.

21. [Online September 2020]

Match the thermodynamic processes taking place in a system with the correct conditions. In the table ΔQ is the heat supplied, ΔW is the work done and ΔU is change in internal energy of the system

Process	Condition
(A) Adiabatic	(p) $\Delta W = 0$
(B) Isothermal	(q) $\Delta Q = 0$
(C) Isochoric	(r) $\Delta U \neq 0, \Delta W \neq 0, \Delta Q \neq 0$
(D) Isobaric	(s) $\Delta U = 0$

- (A) A → (q), B → (s), C → (p), D → (r)
(B) A → (q), B → (p), C → (s), D → (r)
(C) A → (p), B → (p), C → (q), D → (r)
(D) A → (p), B → (q), C → (s), D → (s)

22. [Online September 2020]

Three different processes that can occur in an ideal monatomic gas are shown in the P vs V diagram. The paths are labelled as A → B, A → C and A → D. The change in internal energies during these process are taken as E_{AB}, E_{AC}, E_{AD} and the work done as W_{AB}, W_{AC} and W_{AD} . The correct relation between these parameters are

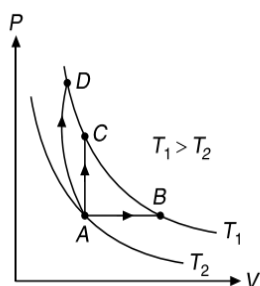

- (A) $E_{AB} = E_{AC} = E_{AD}, W_{AB} > 0, W_{AC} = 0, W_{AD} > 0$
(B) $E_{AB} < E_{AC} < E_{AD}, W_{AB} > 0, W_{AC} > W_{AD}$
(C) $E_{AB} = E_{AC} < E_{AD}, W_{AB} > 0, W_{AC} = 0, W_{AD} > 0$
(D) $E_{AB} > E_{AC} > E_{AD}, W_{AB} < W_{AC} < W_{AD}$

23. [Online September 2020]

In an adiabatic process, the density of a diatomic gas becomes 32 times its initial value. The final pressure of the gas is found to be n times the initial pressure. The value of n is

- (A) 326 (B) $\frac{1}{32}$
(C) 32 (D) 128

24. [Online September 2020]

An engine operates by taking a monatomic ideal gas through the cycle shown in Figure.

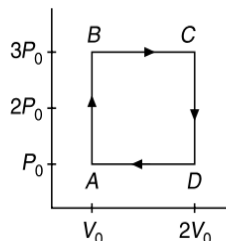

The percentage efficiency of the engine is close to _____.

25. [Online September 2020]

A metallic sphere cools from 50 °C to 40 °C in 300 s. If atmospheric temperature around is 20 °C, then the sphere's temperature after the next 5 minutes will be close to

- (A) 33 °C (B) 35 °C
(C) 31 °C (D) 28 °C

26. [Online September 2020]

Three rods of identical cross-section and lengths are made of three different materials of thermal conductivity $K_1, K_2,$ and $K_3,$ respectively. They are joined together at their ends to make a long rod (see figure). One end of the long rod is maintained at 100 °C and the other at 0 °C (see figure). If the joints of the rod are at 70 °C and 20 °C in steady state the there is no loss of energy from the surface of the rod, the correct relationship between K_1, K_2 and K_3 is

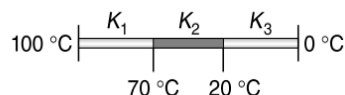

- (A) $K_1 : K_3 = 2 : 3; K_2 : K_3 = 2 : 5$
(B) $K_1 < K_2 < K_3$
(C) $K_1 : K_2 = 5 : 2; K_1 : K_3 = 3 : 5$
(D) $K_1 > K_2 > K_3$

27. [Online January 2020]

A Carnot engine having an efficiency of $\frac{1}{10}$ is being used as a refrigerator. If the work done on the refrigerator is 10 J, the amount of heat absorbed from the reservoir at lower temperature is

- (A) 99 J (B) 100 J
(C) 90 J (D) 1 J

28. [Online January 2020]

Which of the following is an equivalent cyclic process corresponding to the thermodynamic cyclic given in Figure? Where, 1 → 2 is adiabatic. (Graphs are schematic and are not to scale)

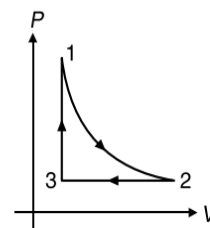

2.174 JEE Advanced Physics: Waves and Thermodynamics

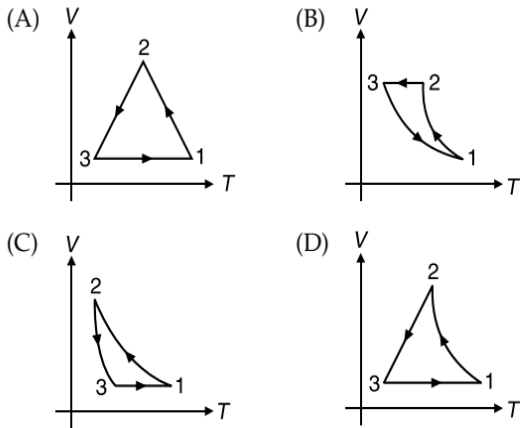

29. [Online January 2020]

Starting at temperature 300 K, one mole of an ideal diatomic gas ($\gamma = 1.4$) is first compressed adiabatically from volume V_1 to $V_2 = \frac{V_1}{16}$. It is then allowed to expand isobarically to volume $2V_2$. If all the processes are the quasi-static then the final temperature of the gas (in $^{\circ}\text{K}$) is (to the nearest integer) _____.

30. [Online January 2020]

An engine takes in 5 moles of air at 20°C and 1 atm, and compresses it adiabatically to $\frac{1}{10^{\text{th}}}$ of the original volume. Assuming air to be a diatomic ideal gas made up of rigid molecules, the change in its internal energy during this process comes out to be X kJ. The value of X to the nearest integer is _____.

31. [Online January 2020]

Two moles of an ideal gas with $\frac{C_P}{C_V} = \frac{5}{3}$ are mixed with 3 moles of another ideal gas with $\frac{C_P}{C_V} = \frac{4}{3}$. The value of $\frac{C_P}{C_V}$ for the mixture is

(A) 1.50 (B) 1.42
(C) 1.45 (D) 1.47

32. [Online January 2020]

A non-isotropic solid metal cube has coefficients of linear expansion as $5 \times 10^{-5} \text{ }^{\circ}\text{C}^{-1}$ along the x -axis and $5 \times 10^{-6} \text{ }^{\circ}\text{C}^{-1}$ along the y and the z -axis. If the coefficient of volume expansion of the solid is $C \times 10^{-16} \text{ }^{\circ}\text{C}^{-1}$ then the value of C is _____.

33. [Online January 2020]

M gram of steam at 100°C is mixed with 200 g of ice at its melting point in a thermally insulated container. If it produces liquid water at 40°C (heat of vaporization of water is 540 calg^{-1} and heat of fusion of ice is 80 calg^{-1}), the value of M is _____.

34. [Online January 2020]

Consider a mixture of n moles of helium gas and $2n$ moles of oxygen gas (molecules taken to be rigid) as an ideal gas. Its $\frac{C_P}{C_V}$ value will be

- (A) $\frac{67}{45}$ (B) $\frac{19}{13}$
(C) $\frac{23}{15}$ (D) $\frac{40}{27}$

35. [Online January 2020]

Three containers C_1 , C_2 and C_3 have water at different temperatures. The table below shows the final temperature T when different amounts of water (given in liters) are taken from each containers and mixed (assume no loss of heat during the process)

C_1	C_2	C_3	T
1 lt	2 lt	–	60°C
–	1 lt	2 lt	30°C
2 lt	–	1 lt	60°C
1 lt	1 lt	1 lt	θ

The value of θ (in $^{\circ}\text{C}$ to the nearest integer) is.....

36. [Online January 2020]

Consider two ideal diatomic gases A and B at some temperature T . Molecules of the gas A are rigid, and have a mass m . Molecules of the gas B have an additional vibrational mode, and have a mass $\frac{m}{4}$. The ratio of the specific heats (C_V^A and C_V^B) of gas A and B , respectively is

- (A) 7:9 (B) 5:7
(C) 3:5 (D) 5:9

37. [Online January 2020]

Two gases argon (atomic radius 0.07 nm, atomic weight 40) and xenon (atomic radius 0.1 nm, atomic weight 140) have the same number density and are at the same temperature. The ratio of their respective mean free times is closest to

- (A) 3.67 (B) 4.67
(C) 1.83 (D) 2.3

38. [Online April 2019]

A thermally insulated vessel contains 150 g of water at 0°C . Then the air from the vessel is pumped out adiabatically. A fraction of water turns into ice and the rest evaporates at 0°C itself. The mass of evaporated water will be closest to (Latent heat of vaporization of water = $2.10 \times 10^6 \text{ Jkg}^{-1}$ and Latent heat of Fusion of water = $3.36 \times 10^5 \text{ Jkg}^{-1}$)

- (A) 130 g (B) 150 g
(C) 20 g (D) 35 g

39. [Online April 2019]

The given diagram shows four processes i.e., isochoric, isobaric, isothermal and adiabatic. The correct assignment of the processes, in the same order is given by

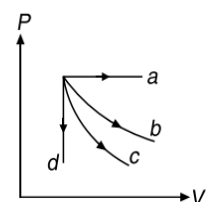

- (A) $adcb$ (B) $adbc$
(C) $dabc$ (D) $dacb$

40. [Online April 2019]

For a given gas at 1 atm pressure, rms speed of the molecules is 200 ms^{-1} at 127°C . At 2 atm pressure and at 227°C , the rms speed of the molecules will be

- (A) $100\sqrt{5} \text{ ms}^{-1}$ (B) 100 ms^{-1}
 (C) $80\sqrt{5} \text{ ms}^{-1}$ (D) 80 ms^{-1}

41. [Online April 2019]

Following figure shows two processes A and B for a gas. If ΔQ_A and ΔQ_B are the amount of heat absorbed by the system in two cases, and ΔU_A and ΔU_B are changes in internal energies, respectively, then

- (A) $\Delta Q_A > \Delta Q_B, \Delta U_A = \Delta U_B$
 (B) $\Delta Q_A = \Delta Q_B, \Delta U_A = \Delta U_B$
 (C) $\Delta Q_A > \Delta Q_B, \Delta U_A > \Delta U_B$
 (D) $\Delta Q_A < \Delta Q_B, \Delta U_A < \Delta U_B$

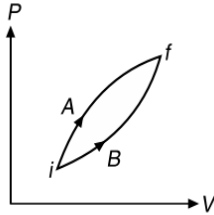

42. [Online April 2019]

An HCl molecule has rotational, translational and vibrational motions. If the rms velocity of HCl molecules in its gaseous phase is \bar{v} , m is its mass and k_B is Boltzmann constant, then its temperature will be

- (A) $\frac{m\bar{v}^2}{5k_B}$ (B) $\frac{m\bar{v}^2}{6k_B}$
 (C) $\frac{m\bar{v}^2}{7k_B}$ (D) $\frac{m\bar{v}^2}{3k_B}$

43. [Online April 2019]

Two identical beakers A and B contain equal volumes of two different liquids at 60°C each and left to cool down. Liquid in A has density of $8 \times 10^2 \text{ kgm}^{-3}$ and specific heat of $2000 \text{ Jkg}^{-1}\text{K}^{-1}$ while liquid in B has density of 10^3 kgm^{-3} and specific heat of $4000 \text{ Jkg}^{-1}\text{K}^{-1}$. Which of the following best describes their temperature versus time graph schematically? (assume the emissivity of both the beakers to be the same)

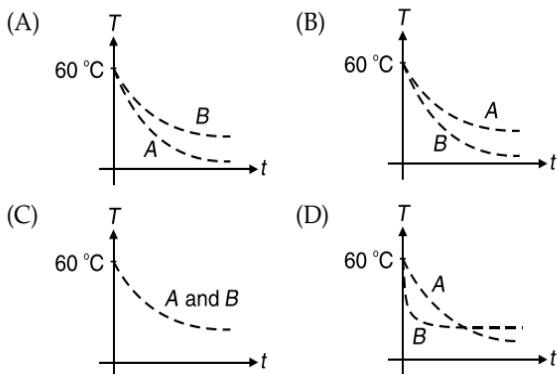

44. [Online April 2019]

The specific heats, C_p and C_v of a gas of diatomic molecules, A, are given (in units of $\text{Jmol}^{-1}\text{K}^{-1}$) by 29 and 22, respectively. Another gas of diatomic molecules, B, has the corresponding values 30 and 21. If they are treated as ideal gases, then

- (A) A is rigid but B has a vibrational mode.
 (B) A has a vibrational mode but B has none.
 (C) Both A and B have a vibrational mode each.
 (D) A has one vibrational mode and B has two.

45. [Online April 2019]

Two materials having coefficients of thermal conductivity $3K$ and K and thickness d and $3d$ respectively, are joined to form a slab as shown in the figure. The temperatures of the outer surfaces are θ_2 and θ_1 respectively, ($\theta_2 > \theta_1$). The temperature at the interface is

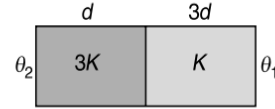

- (A) $\frac{\theta_1 + 5\theta_2}{6}$ (B) $\frac{\theta_1 + 9\theta_2}{10}$
 (C) $\frac{\theta_1 + 2\theta_2}{3}$ (D) $\frac{\theta_2 + \theta_1}{2}$

46. [Online April 2019]

n moles of an ideal gas with constant volume heat capacity C_v undergoes an isobaric expansion by certain volume. The ratio of the work done in the process, to the heat supplied is

- (A) $\frac{4nR}{C_v + nR}$ (B) $\frac{nR}{C_v + nR}$
 (C) $\frac{4nR}{C_v - nR}$ (D) $\frac{nR}{C_v - nR}$

47. [Online April 2019]

A cylinder with fixed capacity of 67.2 lt contains helium gas at STP. The amount of heat needed to raise the temperature of the gas by 20°C is (Given that $R = 8.31 \text{ Jmol}^{-1}\text{K}^{-1}$)

- (A) 700 J (B) 350 J
 (C) 374 J (D) 748 J

48. [Online April 2019]

One mole of an ideal gas passes through a process where pressure and volume obey the relation $P = P_0 \left[1 - \frac{1}{2} \left(\frac{V_0}{V} \right)^2 \right]$. Here P_0 and V_0 are constants. Calculate the change in the temperature of the gas if its volume changes from V_0 to $2V_0$.

- (A) $\frac{1}{4} \frac{P_0 V_0}{R}$ (B) $\frac{5}{4} \frac{P_0 V_0}{R}$
 (C) $\frac{1}{2} \frac{P_0 V_0}{R}$ (D) $\frac{3}{4} \frac{P_0 V_0}{R}$

49. [Online April 2019]

When heat Q is supplied to a diatomic gas of rigid molecules, at constant volume its temperature increases by ΔT . The heat required to produce the same change in temperature, at a constant pressure is

- (A) $\frac{3}{2} Q$ (B) $\frac{2}{3} Q$
 (C) $\frac{7}{5} Q$ (D) $\frac{5}{3} Q$

50. [Online April 2019]

A sample of an ideal gas is taken through the cyclic process $abca$ as shown in the figure. The change in the internal energy of the gas along the path ca is -180 J . The gas absorbs 250 J of heat along the path ab and 60 J along the path bc . The work done by the gas along the path abc is

2.176 JEE Advanced Physics: Waves and Thermodynamics

- (A) 130 J
 (B) 100 J
 (C) 140 J
 (D) 120 J

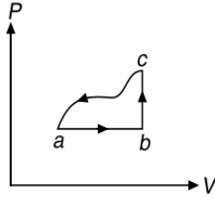

51. [Online April 2019]

When M_1 gram of ice at -10°C (specific heat $0.5 \text{ cal g}^{-1}\text{C}^{-1}$) is added to M_2 gram of water at 50°C , finally no ice is left and the water is at 0°C . The value of latent heat of ice, in cal g^{-1} is

- (A) $\frac{50M_2}{M_1} - 5$ (B) $\frac{5M_1}{M_2} - 50$
 (C) $\frac{50M_2}{M_1}$ (D) $\frac{5M_2}{M_1} - 5$

52. [Online April 2019]

Two moles of helium gas is mixed with three moles of hydrogen molecules (taken to be rigid). What is the molar specific heat of mixture at constant volume?

- ($R = 8.3 \text{ J mol}^{-1}\text{K}^{-1}$)
 (A) $19.7 \text{ J mol}^{-1}\text{K}^{-1}$ (B) $21.6 \text{ J mol}^{-1}\text{K}^{-1}$
 (C) $15.7 \text{ J mol}^{-1}\text{K}^{-1}$ (D) $17.4 \text{ J mol}^{-1}\text{K}^{-1}$

53. [Online April 2019]

A Carnot engine has an efficiency of $\frac{1}{6}$. When the temperature of the sink is reduced by 62°C , its efficiency is doubled. The temperatures of the source and the sink are, respectively,

- (A) $99^\circ\text{C}, 37^\circ\text{C}$ (B) $37^\circ\text{C}, 99^\circ\text{C}$
 (C) $124^\circ\text{C}, 62^\circ\text{C}$ (D) $62^\circ\text{C}, 124^\circ\text{C}$

54. [Online April 2019]

A diatomic gas with rigid molecules does 10 J of work when expanded at constant pressure. What would be the heat energy absorbed by the gas, in this process?

- (A) 30 J (B) 35 J
 (C) 25 J (D) 40 J

55. [Online April 2019]

The temperature, at which the root mean square velocity of hydrogen molecules equals their escape velocity from the earth, is closest to

[Boltzmann constant $k_B = 1.38 \times 10^{-23} \text{ JK}^{-1}$
 Avogadro Number $N_A = 6.02 \times 10^{26} \text{ kg}^{-1}$

Radius of Earth $6.4 \times 10^6 \text{ m}$

Gravitational acceleration on Earth $g = 10 \text{ ms}^{-2}$]

- (A) 10^4 K (B) 650 K
 (C) 800 K (D) $3 \times 10^5 \text{ K}$

56. [Online April 2019]

A $25 \times 10^{-3} \text{ m}^3$ volume cylinder is filled with 1 mol of O_2 gas at room temperature 300 K. The molecular diameter of O_2 and its root mean square speed, are found to be 0.3 nm and 200 ms^{-1} , respectively. What is the average collision rate (per second) for an O_2 molecule?

- (A) $\sim 10^{12}$ (B) $\sim 10^{10}$
 (C) $\sim 10^{11}$ (D) $\sim 10^{13}$

57. [Online April 2019]

The number density of molecules of a gas depends on their distance r from the origin as $n(r) = n_0 e^{-\alpha r^4}$. Then the total number of molecules is proportional to

- (A) $n_0 \alpha^{\frac{3}{4}}$ (B) $\sqrt{n_0} \alpha^{\frac{1}{2}}$
 (C) $n_0 \alpha^{\frac{1}{4}}$ (D) $n_0 \alpha^{-3}$

58. [Online January 2019]

A gas can be taken from A and B via two different processes ACB and ADB. When path ACB is used 60 J of heat flows into the system and 30 J of work is done by the system. If path ADB is used work done by the system is 10 J. The heat flow into the system in path ADB is

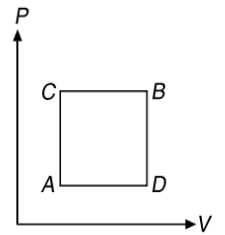

- (A) 100 J (B) 80 J
 (C) 20 J (D) 40 J

59. [Online January 2019]

Temperature difference of 120°C is maintained between two ends of a uniform rod AB of length $2L$. Another bent rod PQ, of same cross-section as AB and length $\frac{3L}{2}$, is connected across AB (see figure). In steady state, temperature difference between P and Q will be close to

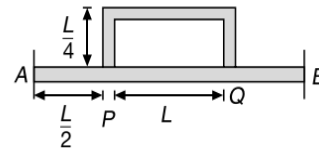

- (A) 35°C (B) 45°C
 (C) 60°C (D) 75°C

60. [Online January 2019]

A mixture of 2 moles of helium gas atomic mass 4 u and 1 mole of argon gas atomic mass 40 u is kept at 300 K in a container. The ratio of their rms speeds $\frac{v_{\text{rms}}(\text{helium})}{v_{\text{rms}}(\text{argon})}$, is close to

- (A) 2.24 (B) 0.45
 (C) 3.16 (D) 0.32

61. [Online January 2019]

A rod, length L at room temperature and uniform area of cross section A , is made of a metal having coefficient of linear expansion $\alpha^\circ\text{C}^{-1}$. It is observed that an external compressive force F , is applied on each of its ends, prevents any change in the length of the rod, when its temperature rises by ΔT kelvin. The Young's modulus Y for this metal is

- (A) $\frac{F}{A\alpha(\Delta T - 273)}$ (B) $\frac{F}{A\alpha\Delta T}$
 (C) $\frac{2F}{A\alpha\Delta T}$ (D) $\frac{F}{2A\alpha\Delta T}$

2.178 JEE Advanced Physics: Waves and Thermodynamics
74. [Online January 2019]

Two rods A and B of identical dimensions are at temperature 30°C . If A is heated upto 180°C and B upto $T^\circ\text{C}$, then the new lengths are the same. If the ratio of the coefficients of linear expansion of A and B is $4 : 3$, then the value of T is

(A) 270°C (B) 230°C
 (C) 250°C (D) 200°C

75. [Online January 2019]

In a process, temperature and volume of one mole of an ideal monoatomic gas are varied according to the relation $VT = K$, where K is a constant. In this process, the temperature of the gas is increased by ΔT . The amount of heat absorbed by gas is (R is gas constant)

- (A) $\frac{3}{2}R\Delta T$ (B) $\frac{1}{2}R\Delta T$
 (C) $\frac{2K}{3}\Delta T$ (D) $\frac{1}{2}KR\Delta T$

76. [Online January 2019]

A thermometer graduated according to a linear scale reads a value x_0 when in contact with boiling water, and $\frac{x_0}{3}$ when in contact with ice. What is the temperature of an object in $^\circ\text{C}$, if this thermometer in the contact with the object reads $\frac{x_0}{2}$?

- (A) 40 (B) 60
 (C) 35 (D) 25

77. [Online January 2019]

For the given cyclic process CAB as shown for a gas, the work done is

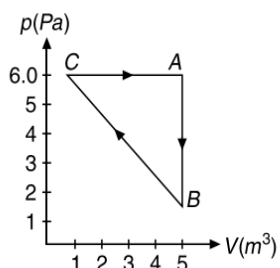

- (A) 30 J (B) 10 J
 (C) 5 J (D) 1 J

78. [Online January 2019]

A cylinder of radius R is surrounded by a cylindrical shell of inner radius R and outer radius $2R$. The thermal conductivity of the material of the inner cylinder is K_1 and that of the outer cylinder is K_2 . Assuming no loss of heat, the effective thermal conductivity of the system for heat flowing along the length of the cylinder is

- (A) $\frac{K_1 + K_2}{2}$ (B) $\frac{K_1 + 3K_2}{4}$
 (C) $K_1 + K_2$ (D) $\frac{2K_1 + 3K_2}{5}$

79. [Online January 2019]

An ideal gas occupies a volume of 2 m^3 at a pressure of $3 \times 10^6\text{ Pa}$. The energy of the gas is

- (A) 10^8 J (B) $9 \times 10^6\text{ J}$
 (C) $6 \times 10^4\text{ J}$ (D) $3 \times 10^2\text{ J}$

80. [Online January 2019]

A vertical closed cylinder is separated into two parts by a frictionless piston of mass m and of negligible thickness. The piston is free to move along the length of the cylinder. The length of the cylinder above the piston is l_1 , and that below the piston is l_2 , such that $l_1 > l_2$. Each part of the cylinder contains n moles of an ideal gas at equal temperature T . If the piston is stationary, its mass, m will be given by: (R is universal gas constant and g is the acceleration due to gravity)

- (A) $\frac{nRT}{g} \left(\frac{l_1 - l_2}{l_1 l_2} \right)$ (B) $\frac{nRT}{g} \left(\frac{1}{l_2} + \frac{1}{l_1} \right)$
 (C) $\frac{RT}{g} \left(\frac{2l_1 + l_2}{l_1 l_2} \right)$ (D) $\frac{RT}{ng} \left(\frac{l_1 - 3l_2}{l_1 l_2} \right)$

81. [Online January 2019]

An ideal gas is enclosed in a cylinder at pressure of 2 atm and temperature, 300 K. The mean time between two successive collisions is $6 \times 10^{-8}\text{ s}$. If the pressure is doubled and temperature is increased to 500 K, the mean time between two successive collisions will be close to

- (A) $2 \times 10^{-7}\text{ s}$ (B) $3 \times 10^{-6}\text{ s}$
 (C) $0.5 \times 10^{-8}\text{ s}$ (D) $4 \times 10^{-8}\text{ s}$

82. [2018]

The mass of a hydrogen molecule is $3.32 \times 10^{-27}\text{ kg}$. If 10^{23} hydrogen molecules strike, second, a fixed wall of area 2 cm^2 at an angle of 45° to the normal, and rebound elastically with a speed of 10^3 ms^{-1} , then the pressure on the wall is nearly

- (A) $2.35 \times 10^3\text{ Nm}^{-2}$ (B) $4.70 \times 10^3\text{ Nm}^{-2}$
 (C) $2.35 \times 10^2\text{ Nm}^{-2}$ (D) $4.70 \times 10^2\text{ Nm}^{-2}$

83. [Online 2018]

The value closest to the thermal velocity of a Helium atom at room temperature (300 K) in ms^{-1} is [$k_B = 1.4 \times 10^{-23}\text{ JK}^{-1}$; $m_{\text{He}} = 7 \times 10^{-27}\text{ kg}$]

- (A) 1.3×10^3 (B) 1.3×10^5
 (C) 1.3×10^2 (D) 1.3×10^4

84. [Online 2018]

Two moles of helium are mixed with n moles of hydrogen.

If $\frac{C_p}{C_v} = \frac{3}{2}$ for the mixture, then the value of n is

- (A) 1 (B) 2
 (C) 3 (D) $\frac{3}{2}$

85. [2018]

Two moles of an idea monatomic gas occupies a volume V at 27°C . The gas expands adiabatically to a volume $2V$. Calculate (1) the final temperature of the gas and (2) change in its internal energy.

- (A) (1) 198 K (2) 2.7 kJ
 (B) (1) 195 K (2) -2.7 kJ
 (C) (1) 189 K (2) -2.7 kJ
 (D) (1) 195 K (2) 2.7 kJ

86. [Online 2018]

One mole of an ideal monoatomic gas is compressed isothermally in a rigid vessel to double its pressure at room temperature, 27 °C. The work done on the gas will be

- (A) $300R$ (B) $300R \ln 2$
(C) $300R \ln 6$ (D) $300R \ln 7$

87. [Online 2018]

A Carnot engine works as a refrigerator between 250 K and 300 K. It receives 500 cal heat from the reservoir at the lower temperature. The amount of work done in each cycle to operate the refrigerator is

- (A) 2520 J (B) 772 J
(C) 2100 J (D) 420 J

88. [Online 2018]

Two Carnot engines A and B are operated in series. Engine A receives heat from a reservoir at 60 K and rejects heat to a reservoir at temperature T . Engine B receives heat rejected by engine A and in turn rejects it to a reservoir at 100 K. If the efficiencies of the two engines A and B are represented by η_A and η_B , respectively, then what is the value of $\frac{\eta_B}{\eta_A}$?

- (A) $\frac{7}{12}$ (B) $\frac{5}{12}$
(C) $\frac{12}{7}$ (D) $\frac{12}{5}$

89. [Online 2018]

One mole of an ideal monoatomic gas is taken along the path $ABCA$ as shown in the PV diagram. The maximum temperature attained by the gas along the path BC is given by

- (A) $\frac{5 P_0 V_0}{8 R}$
(B) $\frac{25 P_0 V_0}{8 R}$
(C) $\frac{25 P_0 V_0}{4 R}$
(D) $\frac{25 P_0 V_0}{16 R}$

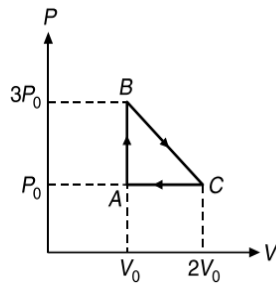

90. [2017]

C_p and C_v are specific heats at constant pressure and constant volume respectively. It is observed that

$C_p - C_v = a$ for hydrogen gas

$C_p - C_v = b$ for nitrogen gas

The correct relation between a and b is

- (A) $a = \frac{1}{14}b$ (B) $a = b$
(C) $a = 14b$ (D) $a = 28b$

91. [Online 2017]

An ideal gas has molecules with 5 degrees of freedom. The ratio of specific heats at constant pressure (C_p) and at constant volume (C_v) is

- (A) 6 (B) $\frac{7}{2}$
(C) $\frac{5}{2}$ (D) $\frac{7}{5}$

92. [Online 2017]

N moles of a diatomic gas in a cylinder are at a temperature T . Heat is supplied to the cylinder such that the temperature remains constant but n moles of the diatomic gas get converted into monoatomic gas. What is the change in the total kinetic energy of the gas?

- (A) 0 (B) $\frac{5}{2}nRT$
(C) $\frac{1}{2}nRT$ (D) $\frac{3}{2}nRT$

93. [2017]

The temperature of an open room of volume 30 m^3 increases from 17 °C to 27 °C due to the sunshine. The atmospheric pressure in the room remains $1 \times 10^5 \text{ Pa}$. If n_i and n_f are the number of molecules in the room before and after heating, then $n_f - n_i$ will be

- (A) -1.61×10^{23} (B) 1.38×10^{23}
(C) 2.5×10^{25} (D) -2.5×10^{25}

94. [2017]

An engine operates by taking n moles of an ideal gas through the cycle $ABCD$ as shown in figure. The thermal efficiency of the figure. The thermal efficiency of the engine is (Take $C_v = 1.5R$, where R is gas constant)

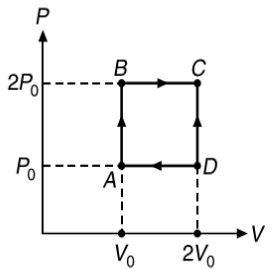

- (A) 0.15 (B) 0.32
(C) 0.24 (D) 0.08

95. [Online 2017]

For the P - V diagram given for an ideal gas, out of the following which one correctly represents the T - P diagram?

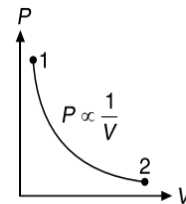

- (A) (B)
(C) (D)

96. [Online 2016]

Which of the following shows the correct relationship between the pressure P and density ρ of an ideal gas at constant temperature?

2.180 JEE Advanced Physics: Waves and Thermodynamics

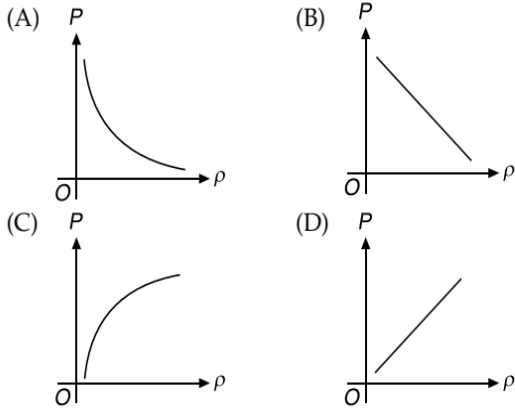

97. [2016]

An ideal gas undergoes a quasi-static, reversible process in which its molar heat capacity C remains constant. If during this process the relation of pressure P and volume V is given by $PV^n = \text{constant}$, then n is given by (Here C_p and C_v are molar specific heat at constant pressure and constant volume, respectively)

- (A) $n = \frac{C - C_v}{C - C_p}$ (B) $n = \frac{C_p}{C_v}$
 (C) $n = \frac{C - C_p}{C - C_v}$ (D) $n = \frac{C_p - C}{C - C_v}$

98. [2016]

n moles of an ideal gas undergoes a process $A \rightarrow B$ as shown in the figure. The maximum temperature of the gas during the process will be

- (A) $\frac{9P_0V_0}{nR}$
 (B) $\frac{9P_0V_0}{4nR}$
 (C) $\frac{3P_0V_0}{2nR}$
 (D) $\frac{9P_0V_0}{2nR}$

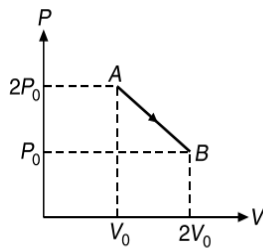

99. [Online 2016]

The ratio of work done by an ideal monoatomic gas to the heat supplied to it in an isobaric process is

- (A) $\frac{2}{5}$ (B) $\frac{3}{2}$
 (C) $\frac{3}{5}$ (D) $\frac{2}{3}$

100. [Online 2016]

200 g water is heated from 40°C to 60°C . Ignoring the slight expansion of water, the change in its internal energy is close to (Given specific heat of water is $4184 \text{ Jkg}^{-1}\text{K}^{-1}$)

- (A) 167.4 kJ (B) 8.4 kJ
 (C) 4.2 kJ (D) 16.7 kJ

101. [Online 2016]

A Carnot freezer takes heat from water at 0°C inside it and rejects it to the room at a temperature of 27°C . The latent heat of ice is $336 \times 10^3 \text{ Jkg}^{-1}$. If 5 kg of water at 0°C is converted into ice at 0°C by the freezer, then the energy consumed by the freezer is close to

- (A) $1.51 \times 10^5 \text{ J}$ (B) $1.68 \times 10^6 \text{ J}$
 (C) $1.71 \times 10^7 \text{ J}$ (D) $1.67 \times 10^5 \text{ J}$

102. [2015]

Consider an ideal gas confined in an isolated closed chamber. As the gas undergoes an adiabatic expansion, the average time of collision between molecules increases as V^q , where V is the volume of the gas. The value of q is $\left(\gamma = \frac{C_p}{C_v}\right)$

- (A) $\frac{3\gamma + 5}{6}$ (B) $\frac{3\gamma - 5}{6}$
 (C) $\frac{\gamma + 1}{2}$ (D) $\frac{\gamma - 1}{2}$

103. [Online 2015]

In an ideal gas at temperature T , the average force that a molecule applies on the walls of a closed container depends on T as T^q . A good estimate for q is

- (A) 2 (B) 1
 (C) $\frac{1}{2}$ (D) $\frac{1}{4}$

104. [Online 2015]

Using equipartition of energy, the specific heat (in $\text{Jkg}^{-1}\text{K}^{-1}$) of aluminium at room temperature can be estimated to be (atomic weight of aluminium = 27)

- (A) 25 (B) 410
 (C) 925 (D) 1850

105. [2015]

A solid body of constant heat capacity $1 \text{ J}/^\circ\text{C}$ is being heated by keeping it in contact with reservoirs in two ways

- (i) Sequentially keeping in contact with 2 reservoirs such that each reservoir supplies same amount of heat.
 (ii) Sequentially keeping in contact with 8 reservoirs such that each reservoir supplies same amount of heat.

In both the cases body is brought from initial temperature 127°C to final temperature 527°C . Entropy change of the body in the two cases respectively is

- (A) $\ln 2, 4\ln 2$ (B) $\ln 2, \ln 2$
 (C) $\ln 2, 2\ln 2$ (D) $2\ln 2, 8\ln 2$

106. [2015]

Consider a spherical shell of radius R at temperature T . The black body radiation inside it can be considered as an ideal gas of photons with internal energy per unit volume $u = \frac{U}{V} \propto T^4$ and pressure $p = \frac{1}{3} \left(\frac{U}{V}\right)$. If the shell now undergoes an adiabatic expansion the relation between T and R is

- (A) $T \propto e^{-R}$ (B) $T \propto e^{-3R}$
 (C) $T \propto \frac{1}{R}$ (D) $T \propto \frac{1}{R^3}$

107. [2014]

One mole of diatomic ideal gas undergoes a cyclic process ABC as shown in figure. The process BC is adiabatic. The temperatures at A , B and C are 400 K , 800 K and 600 K respectively. Choose the correct statement

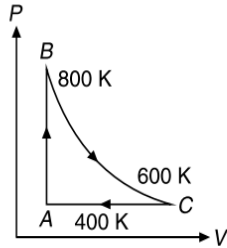

- (A) The change in internal energy in whole cyclic process is $250R$.
- (B) The change in internal energy in the process CA is $700R$.
- (C) The change in internal energy in the process AB is $-350R$.
- (D) The change in internal energy in the process BC is $-500R$.

108. [2013]

The below pressure volume diagram represents the thermodynamic cycle of an engine, operating with an ideal monoatomic gas. The amount of heat, extracted from the source in a single cycle is

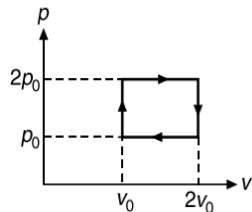

- (A) p_0v_0
- (B) $\left(\frac{13}{2}\right)p_0v_0$
- (C) $\left(\frac{11}{2}\right)p_0v_0$
- (D) $4p_0v_0$

109. [2012]

A Carnot engine, whose efficiency is 40%, takes in heat from a source maintained at a temperature of 500 K. It is desired to have an engine of efficiency 60%. Then, the intake temperature for the same exhaust (sink) temperature must be

- (A) 1200 K
- (B) 750 K
- (C) 600 K
- (D) efficiency of Carnot engine cannot be made larger than 50%

110. [2012]

Helium gas goes through a cycle $ABCD$ (consisting of two isochoric and two isobaric lines) as shown in figure. Efficiency of this cycle is nearly (Assume the gas to be close to ideal gas)

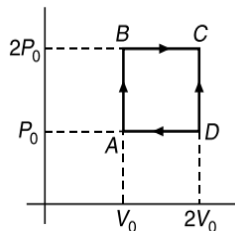

- (A) 9.1%
- (B) 10.5%
- (C) 12.5%
- (D) 15.4%

111. [2011]

A thermally insulated vessel contains an ideal gas of molecular mass M and ratio of specific heats γ . It is moving with speed v and is suddenly brought to rest. Assuming no heat is lost to the surroundings, its temperature increases in kelvin by

- (A) $\frac{(\gamma-1)}{2(\gamma+1)R}Mv^2$
- (B) $\frac{(\gamma-1)}{2\gamma R}Mv^2$
- (C) $\frac{\gamma Mv^2}{2R}$
- (D) $\frac{(\gamma-1)}{2R}Mv^2$

112. [2011]

A Carnot engine operating between temperatures T_1 and T_2 has efficiency $\frac{1}{6}$. When T_2 is lowered by 62 K, its efficiency increases to $\frac{1}{3}$. Then T_1 and T_2 are, respectively

- (A) 372 K and 310 K
- (B) 372 K and 330 K
- (C) 330 K and 268 K
- (D) 310 K and 248 K

113. [2011]

100 g of water is heated from 30 °C to 50 °C. Ignoring the slight expansion of the water, the change in its internal energy is (specific heat of water is $4184 \text{ J kg}^{-1}\text{K}^{-1}$)

- (A) 4.2 kJ
- (B) 8.4 kJ
- (C) 84 kJ
- (D) 2.1 kJ

114. [2010]

A diatomic ideal gas is used in a Carnot engine as the working substance. If during the adiabatic expansion part of the cycle the volume of the gas increases from V to $32V$, the efficiency of the engine is

- (A) 0.25
- (B) 0.5
- (C) 0.75
- (D) 0.99

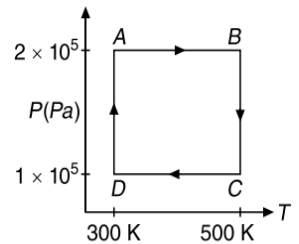

Directions: Question number 115, 116 and 117 are based on the following paragraph. Two moles of helium gas are taken over the cycle $ABCD$, as shown in the P - T diagram. Take $\ln 2 \approx 0.69$

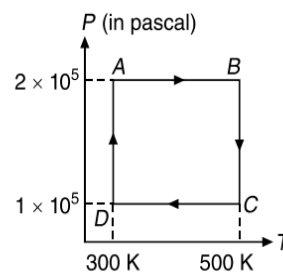

115. [2009]

Assuming the gas to be ideal, the work done on the gas in taking it from A to B is

- (A) $200R$
- (B) $300R$
- (C) $400R$
- (D) $500R$

116. [2009]

The work done on the gas in taking it from D to A is

- (A) $-414R$
- (B) $+414R$
- (C) $-R$
- (D) $+690R$

117. [2009]

The net work done on the gas in the cycle $ABCD$ is

- (A) ZERO
- (B) $276R$
- (C) $1076R$
- (D) $1904R$

2.182 JEE Advanced Physics: Waves and Thermodynamics
118. [2009]

One kg of a diatomic gas is at a pressure of $8 \times 10^4 \text{ Nm}^{-2}$. The density of the gas is 4 kgm^{-3} . What is the energy of the gas due to its thermal motion?

- (A) $3 \times 10^4 \text{ J}$ (B) $5 \times 10^4 \text{ J}$
 (C) $6 \times 10^4 \text{ J}$ (D) $7 \times 10^4 \text{ J}$

ARCHIVE: JEE ADVANCED
Single Correct Choice Type Questions

(In this section each question has four choices (A), (B), (C) and (D), out of which ONLY ONE is correct)

1. [JEE (Advanced) 2019]

A current carrying wire heats a metal rod. The wire provides a constant power (P) to the rod. The metal rod is enclosed in an insulated container. It is observed that the temperature (T) in the metal rod changes with time (t) as

$$T(t) = T_0 \left(1 + \beta t^{\frac{1}{4}} \right)$$

where β is a constant with appropriate dimension while T_0 is a constant with dimension of temperature. The heat capacity of the metal is

- (A) $\frac{4P(T(t) - T_0)^2}{\beta^4 T_0^3}$ (B) $\frac{4P(T(t) - T_0)^4}{\beta^4 T_0^5}$
 (C) $\frac{4P(T(t) - T_0)^3}{\beta^4 T_0^4}$ (D) $\frac{4P(T(t) - T_0)}{\beta^4 T_0^2}$

2. [JEE (Advanced) 2016]

A water cooler of storage capacity 120 litre can cool water at a constant rate of P watts. In a closed circulation system (as shown schematically in Figure), the water from the cooler is used to cool an external device that generates constantly 3 kW of heat (thermal load). The temperature of water fed into the device cannot exceed 30°C and the entire stored 120 litres of water is initially cooled to 10°C . The entire system is thermally insulated. The minimum value of P (in watts) for which the device can be operated for 3 hours is

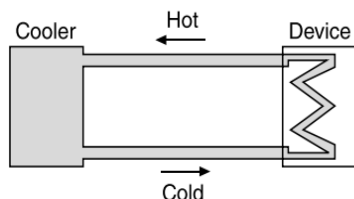

(Specific heat of water is $4.2 \text{ kJkg}^{-1}\text{K}^{-1}$ and the density of water is 1000 kgm^{-3})

- (A) 1600 (B) 2067
 (C) 2533 (D) 3933

3. [JEE (Advanced) 2016]

The ends Q and R of two thin wires, PQ and RS , are soldered (joined) together. Initially, each of the wire has a length of 1 m at 10°C . Now, the end P is maintained at 10°C , while the end S is heated and maintained at 400°C . The system is thermally insulated from its surroundings. If the thermal conductivity of wire PQ is twice that of the wire RS and the coefficient of linear thermal expansion of PQ is $1.2 \times 10^{-5} \text{ K}^{-1}$, the change in length of the wire PQ is

- (A) 0.78 mm (B) 0.90 mm
 (C) 1.56 mm (D) 2.34 mm

4. [JEE (Advanced) 2016]

A gas is enclosed in a cylinder with a movable frictionless piston. Its initial thermodynamic state at pressure $p_i = 10^5 \text{ Pa}$ and volume $V_i = 10^{-3} \text{ m}^3$ changes to a final state at $p_f = \left(\frac{1}{32}\right) \times 10^5 \text{ Pa}$ and $V_f = 8 \times 10^{-3} \text{ m}^3$ in an adiabatic quasi-static process, such that $p^3 V^5 = \text{constant}$. Consider another thermodynamic process that brings the system from the same initial state to the same final state in two steps: an (isovolumetric) process at volume V_f . The amount of heat supplied to the system in the two-step process is approximately

- (A) 112 J (B) 294 J
 (C) 588 J (D) 813 J

5. [JEE (Advanced) 2013]

Two rectangular blocks, having identical dimensions, can be arranged either in configuration I or in configuration II as shown in Figure.

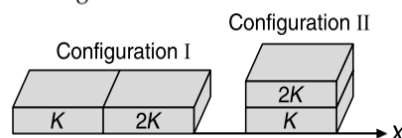

One of the blocks has thermal conductivity K and the other $2K$. The temperature difference between the ends along the X -axis is the same in both the configurations. It takes 9 s to transport a certain amount of heat from the hot end to the cold end in the configuration I. The time to transport the same amount of heat in the configuration II is

- (A) 2.0 s (B) 3.0 s
 (C) 4.5 s (D) 6.0 s

6. [JEE (Advanced) 2013]

Two non-reactive monoatomic ideal gases have their atomic masses in the ratio $2:3$. The ratio of their partial pressures, when enclosed in a vessel kept at a constant temperature, is $4:3$. The ratio of their densities is

- (A) 1:4 (B) 1:2
 (C) 6:9 (D) 8:9

7. [IIT-JEE 2012]

Two moles of ideal helium gas are in a rubber balloon at 30°C . The balloon is fully expandable and can be assumed to require no energy in its expansion. The temperature of the gas in the balloon is slowly changed to 35°C . The amount of heat required in raising the temperature is nearly (take $R = 8.31 \text{ Jmol}^{-1}\text{K}^{-1}$)

2.184 JEE Advanced Physics: Waves and Thermodynamics

20. [IIT-JEE 2004]

Two identical conducting rods are first connected independently to two vessels, one containing water at 100°C and the other containing ice at 0°C . In the second case, the rods are joined end to end and connected to the same vessels. Let q_1 and q_2 g s^{-1} be the rate of melting of ice in the two cases respectively. The ratio $\frac{q_1}{q_2}$ is

- (A) $\frac{1}{2}$ (B) $\frac{2}{1}$
 (C) $\frac{4}{1}$ (D) $\frac{1}{4}$

21. [IIT-JEE 2004]

An ideal gas expands isothermally from a volume V_1 and V_2 and then compressed to original volume V_1 adiabatically. Initial pressure is P_1 and final pressure is P_3 . The total work done is W . Then

- (A) $P_3 > P_1, W > 0$ (B) $P_3 < P_1, W < 0$
 (C) $P_3 > P_1, W < 0$ (D) $P_3 = P_1, W = 0$

22. [IIT-JEE 2004]

Liquid oxygen at 50 K is heated to 300 K at constant pressure of 1 atm . The rate of heating is constant. Which of the following graphs represents the variation of temperature with time?

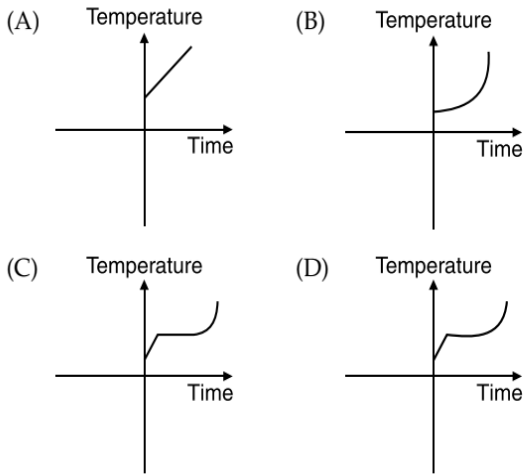

23. [IIT-JEE 2003]

The p - T diagram for an ideal gas is shown in Figure, where AC is an adiabatic process, find the corresponding p - V diagram

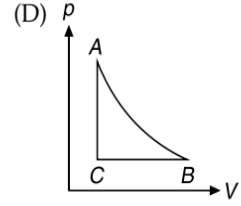
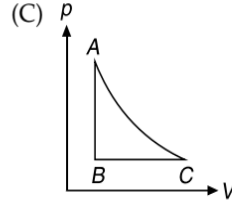
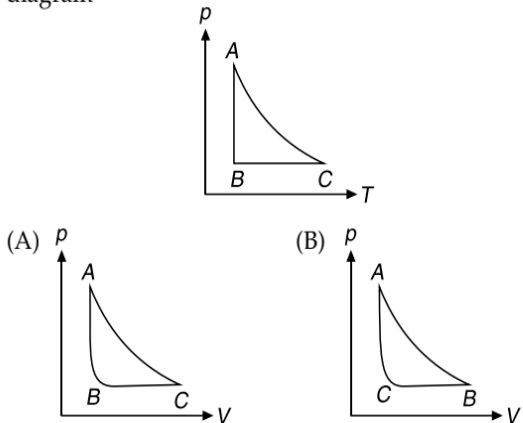

24. [IIT-JEE 2003]

2 kg of ice at -20°C is mixed with 5 kg of water at 20°C in an insulating vessel having a negligible heat capacity. Calculate the final mass of water remaining in the container. It is given that the specific heats of water and ice are $1\text{ kcal kg}^{-1}\text{ }^\circ\text{C}^{-1}$ and $0.5\text{ kcal kg}^{-1}\text{ }^\circ\text{C}^{-1}$ while the latent heat of fusion of ice is 80 kcal kg^{-1} .

- (A) 7 kg (B) 6 kg
 (C) 4 kg (D) 2 kg

25. [IIT-JEE 2003]

Two rods, one of aluminium and the other made of steel, having initial length l_1 and l_2 are connected together to form a single rod of length $l_1 + l_2$. The coefficients of linear expansion for aluminium and steel are α_a and α_s respectively. If the length of each rod increases by the same amount when their temperature are raised by $t^\circ\text{C}$, then find the ratio

- $\frac{l_1}{l_1 + l_2}$
 (A) $\frac{\alpha_s}{\alpha_a}$ (B) $\frac{\alpha_a}{\alpha_s}$
 (C) $\frac{\alpha_s}{(\alpha_a + \alpha_s)}$ (D) $\frac{\alpha_a}{(\alpha_a + \alpha_s)}$

26. [IIT-JEE 2003]

The graph, shown in the diagram, represents the variation of temperature (T) of the bodies, x and y having same surface area, with time (t) due to the emission of radiation. Find the correct relation between the emissivity and absorptivity power of the two bodies

- (A) $E_x > E_y$ and $a_x < a_y$
 (B) $E_x < E_y$ and $a_x > a_y$
 (C) $E_x > E_y$ and $a_x > a_y$
 (D) $E_x < E_y$ and $a_x < a_y$

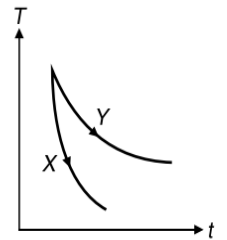

27. [IIT-JEE 2002]

An ideal black-body at room temperature is thrown into a furnace. It is observed that

- (A) initially it is the darkest body and at later times the brightest
 (B) it is the darkest body at all times
 (C) it cannot be distinguished at all times
 (D) initially it is the darkest body and at later times it cannot be distinguished

28. [IIT-JEE 2002]

Which of the following graphs correctly represent the variation of $\beta = -\frac{dV/dP}{V}$ with P for an ideal gas at constant temperature?

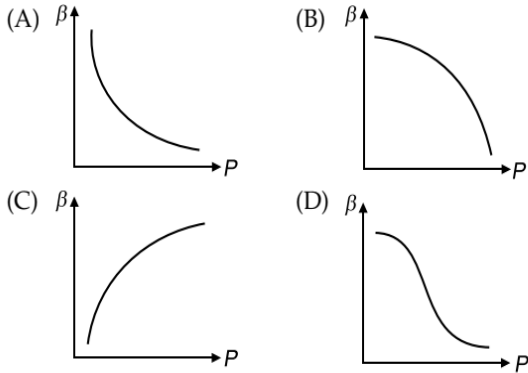

29. [IIT-JEE 2002]

An ideal gas is taken through the cycle $A \rightarrow B \rightarrow C \rightarrow A$, as shown in the figure. If the net heat supplied to the gas in the cycle is 5 J, the work done by the gas in the process is

- (A) -5 J
- (B) -10 J
- (C) -15 J
- (D) -20 J

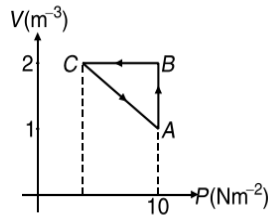

30. [IIT-JEE 2001]

P - V plots for two gases during adiabatic processes are shown in the figure. Plots 1 and 2 should correspond respectively to

- (A) He and O_2
- (B) O_2 and He
- (C) He and Ar
- (D) O_2 and N_2

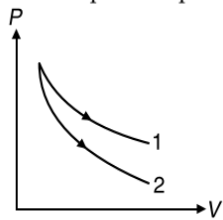

31. [IIT-JEE 2001]

In a given process of an ideal gas, $dW = 0$ and $dQ < 0$. Then for the gas

- (A) the temperature will decrease
- (B) the volume will increase
- (C) the pressure will remain constant
- (D) the temperature will increase

32. [IIT-JEE 2001]

Three rods made of the same material and having the same cross-section have been joined as shown in the figure. Each rod is of the same length. The left and right ends are kept at 0°C and 90°C respectively. The temperature of junction of the three rods will be

- (A) 45°C
- (B) 60°C
- (C) 30°C
- (D) 20°C

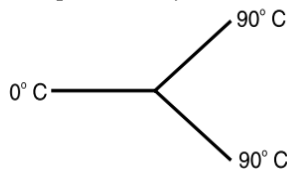

33. [IIT-JEE 2000]

Two monatomic ideal gases 1 and 2 of molecular masses m_1 and m_2 respectively are enclosed in separate containers kept at same temperature. The ratio of the speed of sound in gas 1 to that in gas 2 is given by

- (A) $\sqrt{\frac{m_1}{m_2}}$
- (B) $\sqrt{\frac{m_2}{m_1}}$
- (C) $\frac{m_1}{m_2}$
- (D) $\frac{m_2}{m_1}$

34. [IIT-JEE 2000]

An ideal gas is initially at a temperature T and volume V . Its volume is increased by ΔV due to an increase in temperature ΔT , pressure remaining constant. The quantity

$$\delta = \frac{\Delta V}{V\Delta T}$$

varies with temperature as

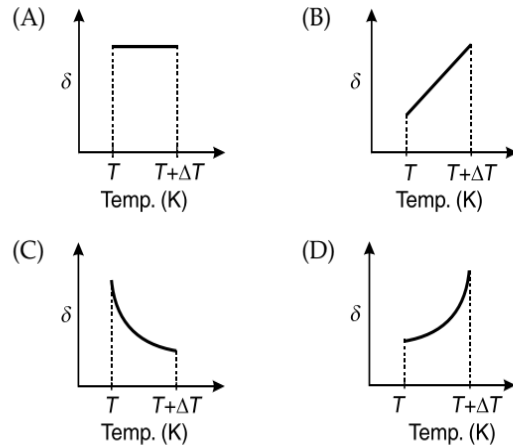

35. [IIT-JEE 2000]

Starting with the same initial conditions, an ideal gas expands from volume V_1 to V_2 in three different ways. The work done by the gas is W_1 if the process is purely isothermal, W_2 if purely isobaric and W_3 if purely adiabatic. Then

- (A) $W_2 > W_1 > W_3$
- (B) $W_2 > W_3 > W_1$
- (C) $W_1 > W_2 > W_3$
- (D) $W_1 > W_3 > W_2$

36. [IIT-JEE 2000]

A block of ice at -10°C is slowly heated and converted to steam at 100°C . Which of the following curves represents the phenomenon qualitatively?

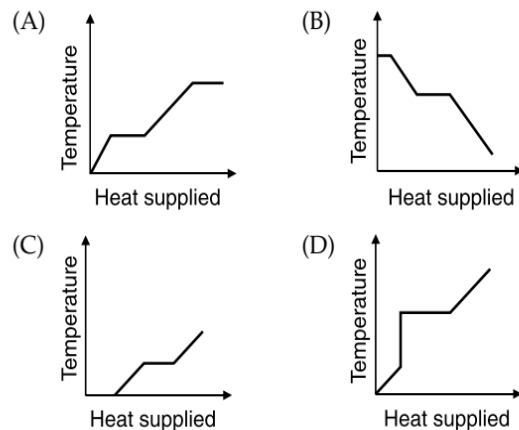

37. [IIT-JEE 2000]

The plots of intensity versus wavelength for three black bodies at temperature T_1 , T_2 and T_3 respectively are as shown. Their temperatures are such that

- (A) $T_1 > T_2 > T_3$
- (B) $T_1 > T_3 > T_2$
- (C) $T_2 > T_3 > T_1$
- (D) $T_3 > T_2 > T_1$

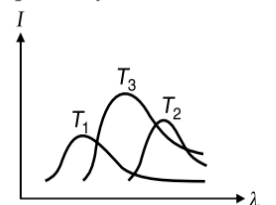

51. [IIT-JEE 1995]

Two metallic spheres S_1 and S_2 are made of the same material and have got identical surface finish. The mass of S_1 is thrice that of S_2 . Both the spheres are heated to the same high temperature and placed in the same room having lower temperature but are thermally insulated from each other. The ratio of the initial rate of cooling of S_1 to that of S_2 is

- (A) $\frac{1}{3}$ (B) $\frac{1}{\sqrt{3}}$
 (C) $\frac{\sqrt{3}}{1}$ (D) $\left(\frac{1}{3}\right)^{1/3}$

52. [IIT-JEE 1995]

Three rods of identical cross-sectional area and made from the same metal form the sides of an isosceles triangle ABC right angled at B . The points A and B are maintained at temperatures T and $\sqrt{2}T$ respectively in the steady state. Assuming the only heat conduction takes place temperature of point C will be

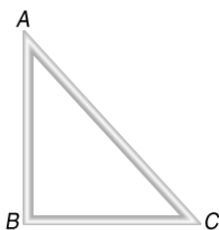

- (A) $\frac{3T}{\sqrt{2}+1}$ (B) $\frac{T}{\sqrt{2}+1}$
 (C) $\frac{T}{\sqrt{3}(\sqrt{2}-1)}$ (D) $\frac{T}{\sqrt{2}-1}$

53. [IIT-JEE 1992]

Three closed vessels A , B and C are at the same temperature and contain gases which obey the Maxwellian distribution of velocities. Vessel A contains only O_2 , B only N_2 and C a mixture of equal quantities of O_2 and N_2 . If the average speed of O_2 molecules in vessel A is v_1 , that of N_2 molecules in vessel B is v_2 , then the average speed of O_2 molecules in vessel C is (Mis the mass of an oxygen molecule)

- (A) $\frac{v_1+v_2}{2}$ (B) v_1
 (C) $\sqrt{v_1v_2}$ (D) $\sqrt{\frac{3k_B T}{M}}$

54. [IIT-JEE 1990]

When an ideal diatomic gas is heated at constant pressure the fraction of the heat energy supplied which increases the internal energy of the gas is

- (A) $\frac{2}{5}$ (B) $\frac{3}{5}$
 (C) $\frac{3}{7}$ (D) $\frac{5}{7}$

55. [IIT-JEE 1988]

One mole of an ideal monatomic gas at temperature T_0 expands slowly according to the law $\frac{P}{V} = \text{constant}$. If the final temperature is $2T_0$, heat supplied to the gas is

- (A) $2RT_0$ (B) $\frac{3}{2}RT_0$
 (C) RT_0 (D) $\frac{1}{2}RT_0$

56. [IIT-JEE 1988]

One mole of monatomic gas is mixed with one mole of diatomic gas. Then $\gamma \left(= \frac{C_P}{C_V} \right)$ for the mixture is

- (A) 1.40 (B) 1.50
 (C) 1.53 (D) 3.07

57. [IIT-JEE 1986]

Steam at 100°C is passed into 1.1 kg of water contained in a calorimeter of water equivalent 0.02 kg at 15°C till the temperature of the calorimeter and its contents rises to 80°C . The mass of the steam condensed in kg is

- (A) 0.130 (B) 0.065
 (C) 0.260 (D) 0.135

58. [IIT-JEE 1985]

70 calorie of heat is required to raise the temperature of 2 mole of an ideal gas at constant pressure from 40°C to 45°C . The amount of heat required to raise the temperature of the same gas through the same range at constant volume is

- (A) 90 calorie (B) 70 calorie
 (C) 50 calorie (D) 30 calorie

59. [IIT-JEE 1984]

At room temperature a diatomic gas is found to have an rms speed of 1930 ms^{-1} . The gas is

- (A) H_2 (B) Cl_2
 (C) O_2 (D) F_2

60. [IIT-JEE 1983]

An ideal monatomic gas is taken round the cycle $ABCD$ as shown in the P - V diagram (shown in figure). The work done during the cycle is

- (A) PV
 (B) $2PV$
 (C) $\frac{1}{2}PV$
 (D) ZERO

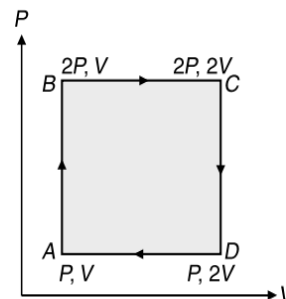

Multiple Correct Choice Type Questions

(In this section each question has four choices (A), (B), (C) and (D), out of which ONE OR MORE is/are correct)

1. [JEE (Advanced) 2020]

The filament of a light bulb has surface area 64 mm^2 . The filament can be considered as a black body at temperature 2500 K emitting radiation like a point source when viewed from far. At night the light bulb is observed from a distance of 100 m . Assume the pupil of the eyes of the observer to be circular with radius 3 mm . Then

(Take Stefan-Boltzmann constant $= 5.67 \times 10^{-8}\text{ Wm}^{-2}\text{K}^{-4}$, Wien's displacement constant $= 2.90 \times 10^{-3}\text{ mK}$, Planck's constant $= 6.63 \times 10^{-34}\text{ Js}$, speed of light in vacuum $= 3.00 \times 10^8\text{ ms}^{-1}$)

2.188 JEE Advanced Physics: Waves and Thermodynamics

- (A) power radiated by the filament is in the range 642 W to 645 W
- (B) radiated power entering into one eye of the observer is in the range 3.15×10^{-8} W to 3.25×10^{-8} W
- (C) the wavelength corresponding to the maximum intensity of light is 1160 nm
- (D) taking the average wavelength of emitted radiation to be 1740 nm, the total number of photons entering per second into one eye of the observer is in the range 2.75×10^{11} to 2.85×10^{11}

2. [JEE (Advanced) 2020]

As shown schematically in Figure, two vessels contain water solutions (at temperature T) of potassium permanganate ($KMnO_4$) of different concentrations n_1 and n_2 ($n_1 > n_2$) molecules per unit volume with $\Delta n = (n_1 - n_2) \ll n_1$. When they are connected by a tube of small length l and cross-sectional area S , $KMnO_4$ starts to diffuse from the left to the right vessel through the tube. Consider the collection of molecules to behave as dilute ideal gases and the difference in their partial pressure in the two vessels causing the diffusion. The speed v of the molecules is limited by the viscous force $-\beta v$ on each molecule, where β is a constant. Neglecting all terms of the order $(\Delta n)^2$, which of the following is/are correct? (k_B is the Boltzmann constant)

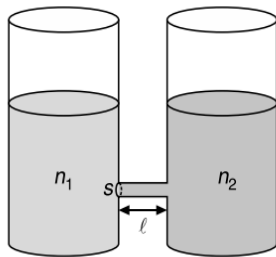

- (A) The force causing the molecules to move across the tube is $\Delta n k_B T S$
- (B) Force balance implies $n_1 \beta v l = \Delta n k_B T$
- (C) Total number of molecules going across the tube per sec is $\left(\frac{\Delta n}{l}\right) \left(\frac{k_B T}{\beta}\right) S$
- (D) Rate of molecules getting transferred through the tube does not change with time

3. [JEE (Advanced) 2019]

A mixture of ideal gas containing 5 moles of monatomic gas and 1 mole of rigid diatomic gas is initially at pressure P_0 , volume V_0 , and temperature T_0 . If the gas mixture is adiabatically compressed to a volume $\frac{V_0}{4}$, then the correct statement(s) is/are, (Given $2^{1.2} = 2.3$; $2^{3.2} = 9.2$; R is gas constant)

- (A) The work $|W|$ done during the process is $13RT_0$
- (B) The final pressure of the gas mixture after compression is in between $9P_0$ and $10P_0$
- (C) Adiabatic constant of the gas mixture is 1.6
- (D) The average kinetic energy of the gas mixture after compression is in between $18RT_0$ and $19RT_0$

4. [JEE (Advanced) 2019]

One mole of a monatomic ideal gas goes through a thermodynamic cycle, as shown in the volume versus temperature VT diagram. The correct statement(s) is/are [R is the gas constant]

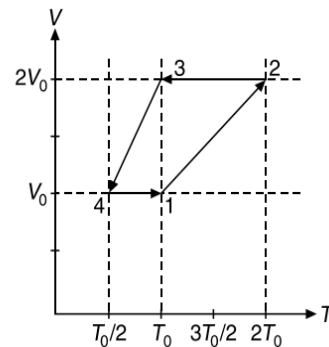

- (A) The above thermodynamic cycle exhibits only isochoric and adiabatic processes
- (B) The ratio of heat transfer during processes $1 \rightarrow 2$ and $3 \rightarrow 4$ is $\left| \frac{Q_{1 \rightarrow 2}}{Q_{3 \rightarrow 4}} \right| = \frac{1}{2}$
- (C) The ratio of heat transfer during processes $1 \rightarrow 2$ and $2 \rightarrow 3$ is $\left| \frac{Q_{1 \rightarrow 2}}{Q_{2 \rightarrow 3}} \right| = \frac{5}{3}$
- (D) Work done in this thermodynamic cycle ($1 \rightarrow 2 \rightarrow 3 \rightarrow 4 \rightarrow 1$) is $|W| = \frac{1}{2} RT_0$

5. [JEE (Advanced) 2018]

One mole of a monatomic ideal gas undergoes a cyclic process as shown in the figure (where V is the volume and T is the temperature). Which of the statements below is (are) true?

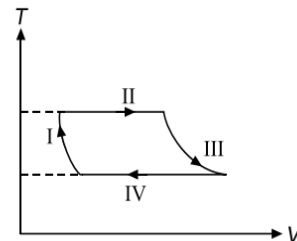

- (A) Process I is an isochoric process
- (B) In process II, gas absorbs heat
- (C) In process IV, gas releases heat
- (D) Processes I and III are not isobaric

6. [JEE (Advanced) 2017]

A human body has a surface area of approximately 1 m^2 . The normal body temperature is 10 K above the surrounding room temperature T_0 . Take the room temperature to be $T_0 = 300 \text{ K}$. For $T_0 = 300 \text{ K}$, the value of $\sigma T_0^4 = 460 \text{ W m}^{-2}$ (where σ is the Stefan Boltzmann constant). Which of the following options is/are correct?

- (A) If the body temperature rises significantly, then the peak in the spectrum of electromagnetic radiation emitted by the body would shift to longer wavelengths
- (B) If the surrounding temperature reduces by a small amount $\Delta T_0 \ll T_0$, then to maintain the same body temperature the same (living) human being needs to radiate $\Delta W = 4\sigma T_0^3 \Delta T_0$ more energy per unit time

- (C) The amount of energy radiated by the body in 1 s is close to 60 J
- (D) Reducing the exposed surface area of the body (e.g. by curling up) allows humans to maintain the same body temperature while reducing the energy lost by radiation

7. [JEE (Advanced) 2015]

A container of fixed volume has a mixture of one mole of hydrogen and one mole of helium in equilibrium at temperature T . Assuming the gases are ideal, the correct statements is/are

- (A) The average energy per mole of the gas mixture is $2RT$
- (B) The ratio of speed of sound in the gas mixture to that in helium gas is $\sqrt{\frac{6}{5}}$
- (C) The ratio of the rms speed of helium atoms to that of hydrogen molecules is $\frac{1}{2}$
- (D) The ratio of the rms speed of helium atoms to that of hydrogen molecules is $\frac{1}{\sqrt{2}}$

8. [JEE (Advanced) 2015]

An ideal monoatomic gas is confined in a horizontal cylinder by a spring piston (as shown in Figure). Initially the gas is at temperature T_1 , pressure p_1 and volume V_1 and the spring is in its relaxed state. The gas is then heated very slowly to temperature T_2 , pressure p_2 and volume V_2 . During this process the piston moves out by a distance x . Ignoring the friction between the piston and the cylinder, the correct statements is/are



- (A) If $V_2 = 2V_1$ and $T_2 = 3T_1$, then the energy stored in the spring is $\frac{1}{4}p_1V_1$
- (B) If $V_2 = 2V_1$ and $T_2 = 3T_1$ then the change in internal energy is $3p_1V_1$
- (C) If $V_2 = 3V_1$ and $T_2 = 4T_1$, then the work done by the gas is $\frac{7}{3}p_1V_1$
- (D) If $V_2 = 3V_1$ and $T_2 = 4T_1$, then the heat supplied to the gas is

9. [JEE (Advanced) 2013]

The figure below shows the variation of specific heat capacity (C) of a solid as a function of temperature (T). The temperature is increased continuously from 0 to 500 K at a constant rate. Ignoring any volume change, the following statement(s) is(are) correct to a reasonable approximation.

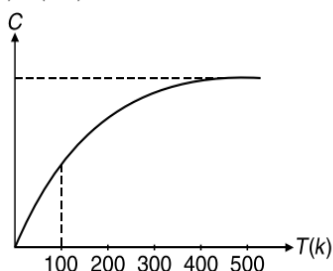

- (A) The rate at which heat is absorbed in the range 0-100 K approximately varies linearly with temperature T .
- (B) Heat absorbed in increasing the temperature from 0-100 K is less than the heat required for increasing the temperature from 400-500 K.
- (C) There is no change in the rate of heat absorption in the range 400-500 K.
- (D) The rate of heat absorption increases in the range 200-300 K.

10. [IIT-JEE 2011]

A composite block is made of slabs A, B, C, D and E of different thermal conductivities (given in terms of a constant K) and sizes (given in terms of length, L) as shown in the figure. All slabs are of same width. Heat Q flows only from left to right through the blocks. Then in steady state

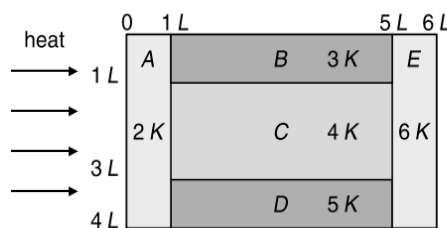

- (A) heat flow through A and E slabs are same
- (B) heat flow through slab E is maximum
- (C) temperature difference across slab E is smallest
- (D) $\left(\text{Heat flow through } C\right) = \left(\text{Heat flow through } B\right) + \left(\text{Heat flow through } D\right)$

11. [IIT-JEE 2009]

C_V and C_P denote the molar specific heat capacities of a gas at constant volume and constant pressure, respectively. Then

- (A) $C_P - C_V$ is larger for a diatomic ideal gas than for a monatomic ideal gas
- (B) $C_P + C_V$ is larger for a diatomic ideal gas than for a monatomic ideal gas
- (C) $\frac{C_P}{C_V}$ is larger for a diatomic ideal gas than for a monatomic ideal gas
- (D) $(C_P)(C_V)$ is larger for a diatomic ideal gas than for a monatomic ideal gas

12. [IIT-JEE 2006]

A black body of temperature T is inside a chamber of temperature T_0 . Now the closed chamber is slightly opened to sun such that temperature of black body (T) and chamber (T_0) remains constant

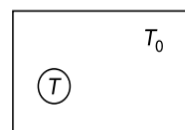

- (A) black body will absorb more radiation
- (B) black body will absorb less radiation
- (C) black body emit more energy
- (D) black body emit energy equal to energy absorbed by it

2.190 JEE Advanced Physics: Waves and Thermodynamics

13. [IIT-JEE 1999]

A bimetallic strip is formed out of two identical strips one of copper and the other of brass. The coefficients of linear expansion of the two metals are α_C and α_B . On heating, the temperature of the strip goes up by ΔT and the strip bends to form an arc of radius of curvature R . Then R is

- (A) proportional to ΔT
- (B) inversely proportional to ΔT
- (C) proportional to $|\alpha_B - \alpha_C|$
- (D) inversely proportional to $|\alpha_B - \alpha_C|$

14. [IIT-JEE 1998]

During the melting of a slab of ice at 273 K at atmospheric pressure

- (A) positive work is done by the ice-water system on the atmosphere
- (B) positive work is done on the ice-water system by the atmosphere
- (C) the internal energy of the ice-water increases
- (D) the internal energy of the ice-water system decreases

15. [IIT-JEE 1998]

Let \bar{v} , v_{rms} and v_p represent respectively the mean speed, root mean square speed and the most probable speed of the molecules in an ideal monatomic gas at absolute temperature T . The mass of the molecule is m . Then

- (A) no molecule can have energy greater than $\sqrt{2}v_{\text{rms}}$
- (B) no molecule can have speed less than $\frac{v_p}{\sqrt{2}}$
- (C) $v_p < \bar{v} < v_{\text{rms}}$
- (D) the average kinetic energy of a molecule is $\frac{3}{4}mv_p^2$

16. [IIT-JEE 1995]

From the following statements concerning ideal gas at any given temperature T , select the correct one(s)

- (A) The coefficient of volume expansion at constant pressure is the same for all ideal gases
- (B) The average translational kinetic energy per molecule of oxygen gas is $3kT$, k being Boltzmann constant
- (C) The mean-free path of molecules increases with increase in the pressure
- (D) In a gaseous mixture, the average translational kinetic energy of the molecules of each component is different

17. [IIT-JEE 1994]

Two bodies A and B have thermal emissivities of 0.01 and 0.81, respectively. The outer surface areas of two bodies are the same. The two bodies emit total radiant power at the same rate. The wavelength λ_B corresponding to maximum spherical spectral radiance in the radiation from B is shifted from the wavelength corresponding to the maximum spectral radiance in from A by $1.00 \mu\text{m}$. If the temperature of A is 5802 K, then

- (A) the temperature of B is 1934 K
- (B) $\lambda_B = 1.5 \mu\text{m}$
- (C) the temperature of B is 11604 K
- (D) the temperature of B is 2901 K

18. [IIT-JEE 1993]

An ideal gas is taken from the state A (pressure P , volume V) to the state B (pressure $P/2$, volume $2V$) along a straight line path in the P - V diagram. Select the correct statements from the following

- (A) The work done by the gas in the process A to B exceeds the work that would be done by it if the system were taken from A to B along an isotherm
- (B) In the T - V diagram, the path AB becomes a part of a parabola
- (C) In the P - T diagram, the path AB becomes a part of a hyperbola
- (D) In going from A to B , the temperature T of the gas first increases to a maximum value and then decreases

19. [IIT-JEE 1989]

For an ideal gas

- (A) the change in internal energy in a constant pressure process from temperature T_1 and T_2 is equal to $nC_V(T_2 - T_1)$, where C_V is the molar heat capacity at constant volume and n the number of moles of the gas.
- (B) the change in internal energy of the gas and the work done by the gas are equal in magnitude in an adiabatic process
- (C) the internal energy does not change in an isothermal process
- (D) no heat is added or removed in an adiabatic process

Reasoning Based Questions

This section contains Reasoning type questions, each having four choices (A), (B), (C) and (D) out of which ONLY ONE is correct. Each question contains STATEMENT 1 and STATEMENT 2. You have to mark your answer as

Bubble (A) If both statements are TRUE and STATEMENT 2 is the correct explanation of STATEMENT 1.

Bubble (B) If both statements are TRUE but STATEMENT 2 is not the correct explanation of STATEMENT 1.

Bubble (C) If STATEMENT 1 is TRUE and STATEMENT 2 is FALSE.

Bubble (D) If STATEMENT 1 is FALSE but STATEMENT 2 is TRUE.

1. [IIT-JEE 2007]

Statement-1: The total translational kinetic energy of all the molecules of a given mass of an ideal gas is 1.5 times the product of its pressure and its volume.

Statement-2: The molecules of a gas collide with each other and the velocities of the molecules change due to the collision.

Matrix Match/Column Match Type Questions

Each question in this section contains statements given in two columns, which have to be matched. The statements in COLUMN-I are labelled A, B, C and D, while the statements in COLUMN-II are labelled p, q, r, s (and t). Any given statement in COLUMN-I can have correct matching with ONE OR MORE statement(s) in COLUMN-II. The appropriate bubbles corresponding to the answers to these questions have to be darkened as illustrated in the following examples:

If the correct matches are A → p, s and t; B → q and r; C → p and q; and D → s and t; then the correct darkening of bubbles will look like the following:

	p	q	r	s	t
A	<input checked="" type="checkbox"/>	<input checked="" type="checkbox"/>	<input type="checkbox"/>	<input checked="" type="checkbox"/>	<input checked="" type="checkbox"/>
B	<input checked="" type="checkbox"/>	<input checked="" type="checkbox"/>	<input type="checkbox"/>	<input type="checkbox"/>	<input type="checkbox"/>
C	<input checked="" type="checkbox"/>	<input checked="" type="checkbox"/>	<input type="checkbox"/>	<input type="checkbox"/>	<input type="checkbox"/>
D	<input checked="" type="checkbox"/>	<input checked="" type="checkbox"/>	<input type="checkbox"/>	<input type="checkbox"/>	<input type="checkbox"/>

1. [JEE (Advance) 2019]

Answer the following by appropriately matching the lists based on the information given in the paragraph. In a thermodynamic process on an ideal monatomic gas, the infinitesimal heat absorbed by the gas is given by $T\Delta X$, where T is temperature of the system and ΔX is the infinitesimal change in a thermodynamic quantity X of the system. For a mole of monatomic ideal gas $X = \frac{3}{2}R\ln\left(\frac{T}{T_A}\right) + R\ln\left(\frac{V}{V_A}\right)$.

Here, R is gas constant, V is volume of gas, T_A and V_A are constants. The COLUMN-I below gives some quantities involved in a process and COLUMN-II gives some possible values of these quantities.

COLUMN-I	COLUMN-II
A. Work done by the system in process 1 → 2 → 3	p. $\frac{1}{3}RT_0 \ln 2$
B. Change in internal energy in process 1 → 2 → 3	q. $\frac{1}{3}RT_0$
C. Heat absorbed by the system in process 1 → 2 → 3	r. RT_0
D. Heat absorbed by the system in process 1 → 2	s. $\frac{4}{3}RT_0$
	t. $\frac{1}{3}RT_0(3 + \ln 2)$
	u. $\frac{5}{6}RT_0$

If the process carried out on one mole of monatomic ideal gas is as shown in figure in the PV diagram with $P_0V_0 = \frac{1}{3}RT_0$, then give the correct match for COLUMN-I in COLUMN-II.

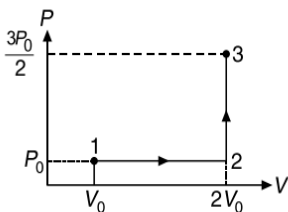

2. [JEE (Advance) 2019]

In a thermodynamic process on an ideal monatomic gas, the infinitesimal heat absorbed by the gas is given by $T\Delta X$, where T is temperature of the system and ΔX is the infinitesimal change in a thermodynamic quantity X of the system. For

$$\text{a mole of monatomic ideal gas } X = \frac{3}{2}R\ln\left(\frac{T}{T_A}\right) + R\ln\left(\frac{V}{V_A}\right).$$

Here, R is gas constant, V is volume of gas, T_A and V_A are constants. The LIST-I below gives some quantities involved in a process and LIST-II gives some possible values of these quantities.

LIST-I	LIST-II
A. Work done by the system in process 1 → 2 → 3	p. $\frac{1}{3}RT_0 \ln 2$
B. Change in internal energy in process 1 → 2 → 3	q. $\frac{1}{3}RT_0$
C. Heat absorbed by the system in process 1 → 2 → 3	r. RT_0
D. Heat absorbed by the system in process 1 → 2	s. $\frac{4}{3}RT_0$
	t. $\frac{1}{3}RT_0(3 + \ln 2)$
	u. $\frac{5}{6}RT_0$

If the process on one mole of monatomic ideal gas is as shown in the TV diagram with $P_0V_0 = \frac{1}{3}RT_0$, the correct match is,

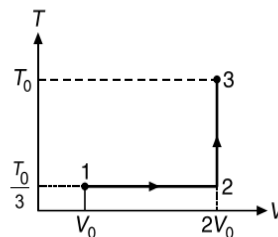

3. [JEE (Advance) 2018]

One mole of a monatomic ideal gas undergoes four thermodynamic processes as shown schematically in the PV -diagram below. Among these four processes, one is isobaric, one is isochoric, one is isothermal and one is adiabatic. Match the processes mentioned in COLUMN-I with the corresponding statements in COLUMN-II.

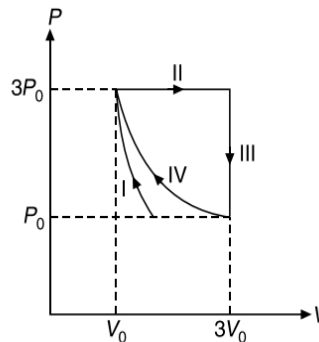

COLUMN-I	COLUMN-II
(A) In process I	(p) Work done by the gas is zero.
(B) In process II	(q) Temperature of the gas remains unchanged.

(Continued)

2.192 JEE Advanced Physics: Waves and Thermodynamics

COLUMN-I	COLUMN-II
(C) In process III	(r) No heat is exchanged between the gas and its surroundings.
(D) In process IV	(s) work done by the gas is $6P_0V_0$.

Directions (Q. Nos. 4-6) Matching the information given in the three columns of the following table.

An ideal gas is undergoing a cyclic thermodynamic process in different ways as shown in the corresponding p - V diagrams in column 3 of the table. Consider only the path from state 1 to state 2. W denotes the corresponding work done on the system. The equations and plots in the table have standards notations and used in thermodynamic process. Here γ is the ratio of heat capacities at constant pressure and constant volume. The number of moles in the gas is n .

COLUMN-I	COLUMN-II	COLUMN-III
(1) $W_{1 \rightarrow 2} = \frac{1}{\gamma - 1}(p_2V_2 - p_1V_1)$	(A) Isothermal	(p)
(2) $W_{1 \rightarrow 2} = -pV_2 + pV_1$	(B) Isochoric	(q)
(3) $W_{1 \rightarrow 2} = 0$	(C) Isobaric	(r)
(4) $W_{1 \rightarrow 2} = -nRT \ln\left(\frac{V_2}{V_1}\right)$	(D) Adiabatic	(s)

4. [JEE (Advanced) 2017]

Which one of the following options correctly represents a thermodynamic process that is used as a correction in the determination of the speed of sound in an ideal gas?

- (A) (4) (B) (r) (B) (1) (B) (Q)
 (C) (1), (D) (q) (D) (3) (D) (R)

5. [JEE (Advanced) 2017]

Which of the following options is the only correct representation of a process in which $\Delta U = \Delta Q - p\Delta V$?

- (A) (2) (C) (s) (B) (2) (C) (p)
 (C) (3) (C) (p) (D) (2) (D) (r)

6. [JEE (Advanced) 2017]

Which one of the following options is the correct combination?

- (A) (2) (D) (p) (B) (3) (B) (s)
 (C) (2) (D) (r) (D) (4) (B) (s)

7. [JEE (Advanced) 2013]

One mole of a monatomic ideal gas is taken along two cyclic processes $E \rightarrow F \rightarrow G \rightarrow E$ and $E \rightarrow F \rightarrow H \rightarrow E$ as shown in the PV diagram. The processes involved are purely isochoric, isobaric, isothermal or adiabatic.

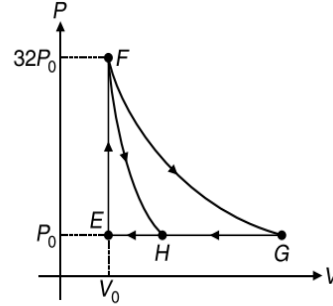

Match the paths in COLUMN-I with the magnitudes of the work done in COLUMN-II.

COLUMN-I	COLUMN-II
(A) $G \rightarrow E$	(p) $160P_0V_0 \log_e 2$
(B) $G \rightarrow H$	(q) $36P_0V_0$
(C) $F \rightarrow H$	(r) $24P_0V_0$
(D) $F \rightarrow G$	(s) $31P_0V_0$

8. [JEE (Advanced) 2011]

One mole of a monatomic ideal gas is taken through a cycle $ABCD$ as shown in the P - V diagram. COLUMN-II gives the characteristics involved in the cycle. Match them with each of the processes given in COLUMN-I.

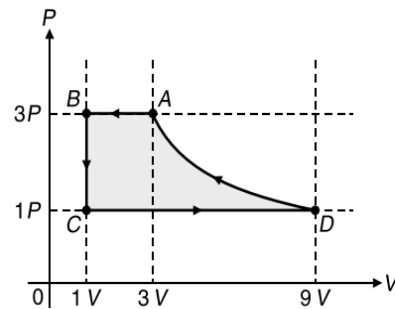

COLUMN-I	COLUMN-II
(A) Process $A \rightarrow B$	(p) Internal energy decreases
(B) Process $B \rightarrow C$	(q) Internal energy increases
(C) Process $C \rightarrow D$	(r) Heat is lost
(D) process $D \rightarrow A$	(s) Heat is gained
	(t) Work is done on the gas

9. [IIT-JEE 2008]

COLUMN-I contains a list of processes involving expansion of an ideal gas. Match this with COLUMN-II describing the thermodynamic change during this process.

2.194 JEE Advanced Physics: Waves and Thermodynamics

2. [JEE (Advanced) 2014]

Now consider the partition to be free to move without friction so that the pressure of gases in both compartments is the same. Then total work done by the gases till the time they achieve equilibrium will be

- (A) 250R (B) 200R
(C) 100R (D) -100R

Comprehension 2

A fixed thermally conducting cylinder has a radius R and height L_0 . The cylinder is open at its bottom and has a small hole at its top. A piston of mass M is held at a distance L from the top surface, as shown in the figure. The atmospheric pressure is P_0 . Based on the above facts, answer the following questions.

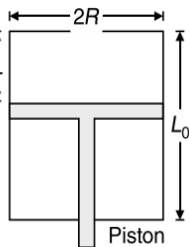

3. [IIT-JEE 2007]

The piston is now pulled out slowly and held at a distance $2L$ from the top. The pressure in the cylinder between its top and piston will then be

- (A) P_0 (B) $\frac{P_0}{2}$
(C) $\frac{P_0}{2} + \frac{Mg}{\pi R^2}$ (D) $\frac{P_0}{2} - \frac{Mg}{\pi R^2}$

4. While the piston is at a distance $2L$ from the top, the hole at the top is sealed. The piston is then released, to a position where it can stay in equilibrium. In this condition, the distance of the piston from the top is

- (A) $\left(\frac{2P_0\pi R^2}{\pi R^2 P_0 + Mg}\right)(2L)$ (B) $\left(\frac{P_0\pi R^2 - Mg}{\pi R^2 P_0}\right)(2L)$
(C) $\left(\frac{P_0\pi R^2 + Mg}{\pi R^2 P_0}\right)(2L)$ (D) $\left(\frac{P_0\pi R^2}{\pi R^2 P_0 - Mg}\right)(2L)$

5. The piston is taken completely out of the cylinder. The hole at the top is sealed. A water tank is brought below the cylinder and put in a position so that the water surface in the tank is at the same level as the top of the cylinder as shown in the figure. The density of the water is ρ . In equilibrium, the height H of the water column in the cylinder satisfies

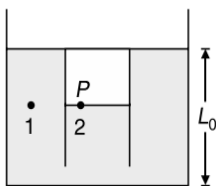

- (A) $\rho g(L_0 - H)^2 + P_0(L_0 - H) + L_0 P_0 = 0$
(B) $\rho g(L_0 - H)^2 - P_0(L_0 - H) - L_0 P_0 = 0$
(C) $\rho g(L_0 - H)^2 + P_0(L_0 - H) - L_0 P_0 = 0$
(D) $\rho g(L_0 - H)^2 - P_0(L_0 - H) + L_0 P_0 = 0$

Integer/Numerical Answer Type Questions

In this section, the answer to each question is a numerical value obtained after series of calculations based on the data provided in the question(s).

1. [JEE (Advanced) 2020]

Consider one mole of helium gas enclosed in a container at initial pressure P_1 and volume V_1 . It expands isothermally to volume $4V_1$. After this, the gas expands adiabatically and its volume becomes $32V_1$. The work done by the gas during isothermal and adiabatic expansion processes are W_{iso} and W_{adia} , respectively. If the ratio $\frac{W_{iso}}{W_{adia}} = f \ln 2$, then f is.....

2. [JEE (Advanced) 2020]

A thermally isolated cylindrical closed vessel of height 8 m is kept vertically. It is divided into two equal parts by a diathermic (perfect thermal conductor) frictionless partition of mass 8.3 kg. Thus, the partition is held initially at a distance of 4 m from the top, as shown in the schematic figure below. Each of the two parts of the vessel contains 0.1 mole of an ideal gas at temperature 300 K. The partition is now released and moves without any gas leaking from one part of the vessel to the other. When equilibrium is reached, the distance of the partition from the top (in m) will be (take the acceleration due to gravity = 10 ms^{-2} and the universal gas constant = $8.3 \text{ Jmol}^{-1}\text{K}^{-1}$)

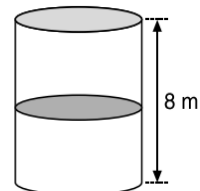

3. [JEE (Advanced) 2020]

A spherical bubble inside water has radius R . Take the pressure inside the bubble and the water pressure to be p_0 . The bubble now gets compressed radially in an adiabatic manner so that its radius becomes $(R - a)$. For $a \ll R$ the magnitude of the work done in the process is given by $(4\pi p_0 R a^2)X$, where X is a constant and $\gamma = \frac{C_p}{C_v} = \frac{41}{30}$. The value of X is.....

4. [JEE (Advanced) 2020]

A container with 1 kg of water in it is kept in sunlight, which causes the water to get warmer than the surroundings. The average energy per unit time per unit area received due to the sunlight is 700 Wm^{-2} and it is absorbed by the water over an effective area of 0.05 m^2 . Assuming that the heat loss from the water to the surroundings is governed by Newton's law of cooling, the difference (in $^\circ\text{C}$) in the temperature of water and the surroundings after a long time will be..... (Ignore effect of the container, and take constant for Newton's law of cooling = 0.001 s^{-1} , Heat capacity of water = $4200 \text{ Jkg}^{-1}\text{K}^{-1}$)

5. [JEE (Advanced) 2019]

A liquid at 30°C is poured very slowly into a Calorimeter that is at temperature of 110°C . The boiling temperature of the liquid is 80°C . It is found that the first 5 g of the liquid completely evaporates. After pouring another 80 g of the liquid the equilibrium temperature is found to be 50°C . The ratio of the latent heat of the liquid to its specific heat will be..... $^\circ\text{C}$. [Neglect the heat exchange with surrounding]

6. [JEE (Advance) 2018]

Two conducting cylinders of equal length but different radii are connected in series between two heat baths kept at temperatures $T_1 = 300 \text{ K}$ and $T_2 = 100 \text{ K}$, as shown in the figure.

The radius of the bigger cylinder is twice that of the smaller one and the thermal conductivities of the materials of the smaller and the larger cylinders are K_1 and K_2 respectively. If the temperature at the junction of the two cylinders is the steady state is 200 K, then $\frac{K_1}{K_2} = \underline{\hspace{2cm}}$.

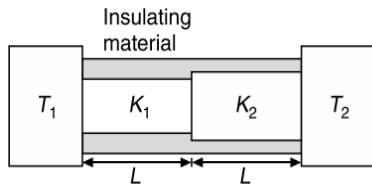

7. [JEE (Advance) 2018]

One mole of a monatomic ideal gas undergoes an adiabatic expansion in which its volume becomes eight times its initial value. If the initial temperature of the gas is 100 K and the universal gas constant $R = 8.0 \text{ J mol}^{-1} \text{ K}^{-1}$, the decrease in its internal energy, in Joule, is _____.

8. [JEE (Advanced) 2016]

A metal is heated in a furnace where a sensor is kept above the metal surface to read the power radiated (P) by the metal. The sensor has a scale that displays $\log_2\left(\frac{P}{P_0}\right)$, where

P_0 is a constant. When the metal surface is at a temperature of 487 °C, then sensor shows a value 1. Assume that the emissivity of the metallic surface remains constant. What is the value displayed by the sensor when the temperature of the metal surface is raised to 2767 °C?

9. [JEE (Advanced) 2015]

Two spherical stars A and B emit black body radiation. The radius of A is 400 times that of B and A emits 10^4 times the power emitted from B . The ratio $\left(\frac{\lambda_A}{\lambda_B}\right)$ of their wavelengths

λ_A and λ_B at which the peaks occur in their respective radiation curves is

10. [JEE (Advanced) 2014]

A thermodynamics system is taken from an initial state i with internal energy $U_i = 100 \text{ J}$ to the final state f along two different paths iaf and ibf , as schematically shown in Figure.

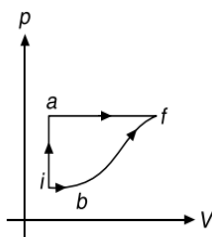

The work done by the system along the paths af , ib and bf are $W_{af} = 200 \text{ J}$, $W_{ib} = 50 \text{ J}$ and $W_{bf} = 100 \text{ J}$ respectively. The heat supplied to the system along the path iaf , ib and bf are Q_{iaf} , Q_{ib} and Q_{bf} respectively. If the internal energy of the system in the state b is $U_b = 200 \text{ J}$ and $Q_{iaf} = 500 \text{ J}$, the ratio $\frac{Q_{bf}}{Q_{ib}}$ is

11. [IIT-JEE 2011]

Steel wire of length L at 40 °C is suspended from the ceiling and then a mass m is hung from its free end. The wire is cooled down from 40 °C to 30 °C to regain its original length L . The coefficient of linear thermal expansion of the steel is $10^{-5} \text{ }^\circ\text{C}^{-1}$, Young's modulus of steel is 10^{11} Nm^{-2} and radius of the wire is 1 mm. Assume that $L \gg$ diameter of the wire. Then the value of m in kg is nearly.

12. [IIT-JEE 2010]

A piece of ice (heat capacity = $2100 \text{ J kg}^{-1} \text{ }^\circ\text{C}^{-1}$ and latent heat = $3.36 \times 10^5 \text{ J kg}^{-1}$) of mass m gram is at $-5 \text{ }^\circ\text{C}$ at atmospheric pressure. It is given 420 J of heat so that the ice starts melting. Finally when the ice-water mixture is in equilibrium, it is found that 1 g of ice has melted. Assuming there is no other heat exchange in the process, find the value of m .

13. [IIT-JEE 2010]

Two spherical bodies A (radius 6 cm) and B (radius 18 cm) are at temperature T_1 and T_2 respectively. The maximum intensity in the emission spectrum of A is at 500 nm and in that of B is at 1500 nm. Considering them to be black bodies, what will be the ratio of the rate of total energy radiated by A to that of B ?

14. [IIT-JEE 2010]

A diatomic ideal gas is compressed adiabatically to $\frac{1}{32}$ of its initial volume. If the initial temperature of the gas is T_i (in Kelvin) and the final temperature is aT_i , then find the value of a .

15. [IIT-JEE 2009]

A metal rod AB of length $10x$ has its one end A in ice at 0 °C and the other end B in water at 100 °C. If a point P on the rod is maintained at 400 °C, then it is found that equal amounts of water and ice evaporate and melt per unit time. The latent heat of evaporation of water is 540 cal g^{-1} and latent heat of melting of ice is 80 cal g^{-1} . If the point P is at a distance of λx from the ice end A , find the value of λ . (Neglect any heat loss to the surrounding).

ANSWER KEYS—TEST YOUR CONCEPTS AND PRACTICE EXERCISES
**Test Your Concepts-I
(Based on Thermometry and Thermal Expansion)**

- (a) too long, (b) 20.0048 cm
- (a) 0.068 cm, (b) 88.49 cm
- 90.01 cm
- (i) $\gamma = 3\alpha$ (ii) $\gamma = 2\alpha$ (iii) $\gamma = 3\alpha$
- 0.00864 cm
- $\frac{V_0(\gamma - 3\alpha)t}{A_0(1 + 2\alpha t)}$
- 36.28 s
- 2.31×10^{-6} dyne
- 1.6×10^3 N
- 4273 K, $(1.5 \times 10^7 + 273)$ K, 6.825%, $1.82 \times 10^{-3}\%$
- $\frac{\sqrt{3}}{200}\theta$
- $\frac{1}{T}$
- -40 °F
- (a) $0.0135 \text{ kgm}^2\text{s}^{-1}$, (b) 3.2×10^{-3}
- (a) 29.94 °C, (b) 118.64 °C
- $\ell_s = 14.16$ cm and $\ell_c = 9.16$ cm
- $2 \times 10^{-5} (\text{°C})^{-1}$
- 7 cm
- 2.5458 cm
- For Neon -248.58 °C, -415.44 °F
For Carbon dioxide -56.60 °C, -69.88 °F
- $\ell_1 = \frac{\ell\alpha_2}{\alpha_2 - \alpha_1}$ and $\ell_2 = \frac{\ell\alpha_1}{\alpha_2 - \alpha_1}$

**Test Your Concepts-II
(Based on Calorimetry)**

- 100 °C, $m_{\text{water}} = 222.26$ g, $m_{\text{steam}} = 7.74$ g
- 8.6×10^{-3} °C
- 200 s
- 23
- 20 °C
- 50 g
- $200 \text{ Jkg}^{-1}(\text{°C})^{-1}$
- 100 °C, 667 g steam, 1333 g water
- 36.67 °C
- $0.481 \text{ calg}^{-1}\text{°C}^{-1}$, 16.55 g
- 20.25 °C
- 410 ms^{-1}
- 0.805 kg
- (a) 37.8 W, (b) 2 Nm
- 178 K
- 27.08 °C

- $4200 \text{ Jkg}^{-1}\text{K}^{-1}$
- 5820 cal
- 100 °C
- 0.8

**Test Your Concepts-III
(Based on Kinetic Theory of Gases and Ideal Gas Equation)**

- 87.76 cm of Hg
- 600 ms^{-1}
- $10^{21} m_0 v$ and 0.073 Nm^{-2}
- $\frac{T}{2} \left(\frac{p_1}{T_1} + \frac{p_2}{T_2} \right)$
- 15.35 cm
- 24 cm
- 2.32×10^{-21} J
- $2.095 \times 10^5 \text{ Nm}^{-2}$
- 76.57 cm of Hg
- 0.026 N
- 115.2 g
- $P_{\text{left}} = 12.471 \times 10^5$ Pa
 $P_{\text{middle}} = 28.06 \times 10^5$ Pa and
 $P_{\text{right}} = 15.589 \times 10^5$ Pa]
- 337.5 K
- (a) 8.26 km, (b) 0.09 km
- RT/Mg
- 5.62×10^{-21} J
- 1.494 kgm^{-3}
- $4.1 \times 10^5 \text{ Nm}^{-2}$
- 13.32 mg
- $p_0 e^{-\frac{M\omega^2 r^2}{2RT}}$
- $-\frac{Mg}{R}$
- 8.5×10^{-2} N
- (a) $p_0(1 - ah)^{Mg/aRT_0}$, (b) $\frac{p_0}{(1 + ah)^{Mg/aRT_0}}$

**Test Your Concepts-IV
(Based on Internal Energy, Degrees of Freedom and Molar Specific Heats for Ideal Gases)**

- $\frac{n_1 T_1 + n_2 T_2}{n_1 + n_2}$
- 2075 J
- (a) 7.3×10^3 J, (b) 6.07×10^{-21} J
- (a) $6.21 \times 10^{-21} \text{ Jmole}^{-1}$ (b) $10.35 \times 10^{-21} \text{ Jmole}^{-1}$
(c) $6235.5 \text{ Jmole}^{-1}$

- 74.8 J
- $\frac{T_1 T_2 (p_1 + p_2)}{p_1 T_2 + p_2 T_1}$, $\frac{p_2 T_1 (p_1 + p_2)}{p_1 T_2 + p_2 T_1}$ and $\frac{3p_1 p_2 V (T_2 - T_1)}{2(p_1 T_2 + p_2 T_1)}$
- 1.4
- $2 \times 10^9 \text{ rads}^{-1}$
- $\frac{2R\Delta T}{\gamma - 1}$

Test Your Concepts-V (Based on Work Done and First Law of Thermodynamics)

- 1
- $3\alpha T_0^2$
- 3.14 J
- 421 kJ, 553 kJ
- Process 1: -60, 50,
Process 2: 5, 80 and
Process 3: 20, 120
- (a) 5 J, (b) -45 J, (c) 40 J, (d) 15 J
- $[6.6 \times 10^5 \text{ J}, 1.8 \times 10^5 \text{ J}, 8.4 \times 10^5 \text{ J}]$
- [7500 J]
- $\frac{\pi}{2} \text{ atm l t}$
- [2400 J, 0 J, -600 J, 0 J, 1800 J]

Test Your Concepts-VI (Based on Isochoric, Isobaric and Isothermal Processes)

- (a) 300R, (b) 500R, (c) 200R
- 320 J
- 2490 J
- 1.4
- 7 J
- (b) $3RT_0 \log_e(2) - \frac{3}{2}RT_0$
(c) $3RT_0 \log_e(2) - \frac{21}{4}RT_0$
- $2\pi \sqrt{\frac{M\ell_0}{2P_0 A + k\ell_0}}$
- 50 J
- $\frac{\log_e(x)}{\log_e\left(1 + \frac{\Delta V}{V}\right)}$
- 24.92 J
- (a) $-2P_0 V_0$ (b) 0
- $RT((n-1) - \log_e(n))$
- (a) 20 cal, (b) 50 cal

Test Your Concepts-VII (Based on Adiabatic Process)

- $2\pi \sqrt{\frac{mV_0}{2\gamma A^2 P_0}}$
- 125 J

- (b) $113.1 \times 10^{-3} \text{ m}^3$, $0.44 \times 10^5 \text{ Nm}^{-2}$
(c) 12470 J]
- 423 K, $W_{\text{adia}} = -82 \text{ J}$, $W_{\text{isob}} = -41 \text{ J}$, $W_{\text{isot}} = 105 \text{ J}$, $W_{\text{total}} = -18 \text{ J}$
- 369.3 K, $2.46 \times 10^5 \text{ Nm}^{-2}$
- 588 K, -5976 J
- (a) Adiabatic
- 100 J
- (a) $\frac{(P_1 + P_2)T_1 T_2}{P_1 T_2 + P_2 T_1}$, $\frac{P_2(P_1 + P_2)T_1}{P_1 T_2 + P_2 T_1}$
(b) $V_{\text{left}} = V \left(\frac{P_1 T_2}{P_2 T_1 + P_1 T_2} \right)$, $V_{\text{right}} = V \left(\frac{P_2 T_1}{P_2 T_1 + P_1 T_2} \right)$
- 1.533, 1.153
- $C_p = \left(1 - \frac{T_0}{V_0} \tan \theta \right) R$, $C_v = \frac{RT_0 \tan \theta}{V_0}$

Test Your Concepts-VIII (Based on Polytopic Process)

- $\frac{3}{2}RT$
- (a) $W = \alpha \ln(\eta) - \frac{RT_0(\eta - 1)}{(\gamma - 1)}$
(b) $PV^\gamma e^{\frac{\alpha(\gamma - 1)}{PV}} = \text{constant}$
- $\frac{2P_0}{3R} \sqrt{\frac{P_0}{3\alpha}}$
- $C = C_v + \frac{R}{\alpha V}$, $C = C_v + \frac{R}{1 + \alpha V}$
- $\frac{\gamma R \Delta T}{1 - \gamma}$
- 3R
- $\Delta U = \frac{\alpha V^2}{\gamma - 1}(\eta^2 - 1)$, $W = \frac{\alpha V^2}{2}(\eta^2 - 1)$, $C = C_v + \frac{R}{2}$
- $\alpha = -\gamma$
- (a) 500 J, (b) $C = 2R$

Test Your Concepts-IX (Based on Cyclic Process, Heat Engine and Refrigerator)

- 1200R, $Q_{AB} = -2100R$, $Q_{BC} = 1500R$ and $Q_{CA} = 831.6R$
- $\eta = 1 - \frac{T_2}{T_1}$
- $W = \frac{1}{2}nR \left(\frac{T_3}{T_2} + \frac{T_2}{T_1} - 2 \right) (T_2 - T_1)$
- 4525.6 J
- 2304.64 J
- 2075 J
- $\eta = 1 - \gamma \left(\frac{n-1}{n^\gamma - 1} \right)$

2.198 JEE Advanced Physics: Waves and Thermodynamics

9. $U_C = 140 \text{ J}, Q_{AB} = 70 \text{ J}, Q_{CA} = -180 \text{ J}$

$W_{ABCA} = -20 \text{ J}$

10. $\eta = \left(\frac{\gamma - 1}{1 + \gamma n} \right) (n - 1)$

**Test Your Concepts-X
(Based on Conduction)**

1. (a) 1.6×10^3 watt, (b) 1.75

2. (a) $84 \text{ }^\circ\text{C}$, (b) 1.28 cal s^{-1}

3. $\frac{mL}{100\pi k \ell} \log_e \left(\frac{r_2}{r_1} \right)$

4. 10.34 cm from water at $100 \text{ }^\circ\text{C}$

5. $145.5 \text{ }^\circ\text{C}, 118.2 \text{ }^\circ\text{C}$

6. $T = (\Delta T)_0 e^{-\alpha t}$, where $\alpha = \frac{kA(C_1 + C_2)}{\ell C_1 C_2}$

7. $0.87 \text{ (}^\circ\text{C)cm}^{-1}$

8. 166 s

9. (a) $T = T_S + (T_S - T_0) e^{-\alpha t}$, where $\alpha = \frac{2T_0 kA}{5P_0 V_0 a}$ (b) $h = \left(\frac{T}{T_0} \right) h_0$

10. $t = \frac{15nR\ell}{16kA} \log_e (2)$

**Test Your Concepts-XI
(Based on Radiation)**

1. 9 minute

2. 969.3 K

3. $36.6 \text{ Wm}^{-1}\text{K}^{-1}$

4. $1.01 \times 10^5 \text{ s}$

5. $\frac{\rho dc(\eta^3 - 1)}{18\sigma e T_0^3}$

6. $0.206 \text{ }^\circ\text{C s}^{-1}$

7. $T = 2000 \left[\log_e \left(\frac{10}{5+x} \right) + 1 \right]$

8. $0.115 \text{ }^\circ\text{C s}^{-1}$

9. 0.3

10. 76.2 min

11. 800 kgm^{-3}

12. 3000 K

Single Correct Choice Type Questions

1. B	2. B	3. B	4. C	5. C	6. B	7. B	8. B	9. C	10. C
11. D	12. D	13. A	14. C	15. B	16. D	17. D	18. B	19. C	20. D
21. C	22. B	23. C	24. A	25. C	26. C	27. B	28. B	29. A	30. A
31. C	32. A	33. C	34. A	35. D	36. B	37. A	38. C	39. B	40. C
41. A	42. C	43. C	44. D	45. C	46. B	47. C	48. D	49. B	50. B
51. D	52. C	53. A	54. D	55. C	56. C	57. C	58. C	59. A	60. C
61. A	62. D	63. B	64. B	65. D	66. C	67. D	68. B	69. C	70. A
71. C	72. B	73. A	74. C	75. A	76. A	77. B	78. A	79. C	80. B
81. B	82. B	83. A	84. D	85. A	86. C	87. C	88. A	89. A	90. D
91. D	92. B	93. C	94. B	95. D	96. D	97. D	98. A	99. D	100. B
101. A	102. D	103. C	104. C	105. B	106. C	107. A	108. B	109. A	110. C
111. D	112. A	113. B	114. A	115. B	116. D	117. C	118. C	119. A	120. C
121. A	122. C	123. B	124. A	125. D	126. C	127. C	128. C	129. C	130. B
131. D	132. C	133. C	134. A	135. A	136. C	137. A	138. B	139. D	140. B
141. D	142. C	143. B	144. B	145. B	146. D	147. D	148. B	149. A	150. A
151. D	152. D	153. C	154. B	155. A	156. C	157. B	158. B	159. B	160. C
161. B	162. A	163. A	164. C	165. A	166. A	167. A	168. C	169. B	170. B
171. D	172. A	173. D	174. B	175. D	176. B	177. D	178. B	179. A	180. B
181. C	182. C	183. B	184. A	185. B	186. B	187. A	188. C	189. D	190. B
191. D	192. C	193. B	194. D	195. A	196. C	197. D	198. B	199. D	200. B
201. A	202. B	203. C	204. A	205. B	206. B	207. C	208. D	209. A	210. A
211. C	212. B	213. C	214. A	215. B	216. C	217. A	218. B	219. B	220. D
221. B	222. C	223. A	224. B	225. A	226. A	227. D	228. A	229. D	230. D

231. D	232. B	233. C	234. C	235. D	236. A	237. B	238. B	239. C	240. C
241. D	242. B	243. C	244. C	245. C	246. C	247. C	248. A	249. C	250. B
251. D	252. B	253. C	254. C	255. B	256. B	257. D	258. C	259. A	260. D
261. B	262. B	263. B	264. A	265. A	266. A	267. A	268. B	269. C	270. C
271. A	272. C	273. B	274. B	275. C	276. D	277. C	278. B	279. A	280. A
281. B	282. B	283. A	284. C	285. B	286. C	287. C	288. A	289. C	290. C
291. C	292. A	293. A	294. B	295. D					

Multiple Correct Choice Type Questions

1. A, B, C	2. A, B, C	3. A, C	4. A, B, C	5. A, C
6. C, D	7. B, C	8. A, D	9. A, D	10. A, B
11. B, C	12. B, C	13. A, B, C	14. A, B, C	15. A, C
16. A, B, C	17. B, D	18. B, D	19. C, D	20. A, C
21. A, B	22. A, B, D	23. A, B	24. A, B, C, D	25. B, D
26. A, D	27. A, C	28. A, B, C, D	29. B, C, D	30. B, D
31. A, B, C, D	32. C, D	33. A, B, C	34. A, B	35. A, B, C, D
36. A, B	37. A, C, D	38. A, C	39. A, B	40. D
41. B, C, D	42. A, C	43. A, B	44. C, D	45. A, B, D
46. C, D	47. B, C	48. A, C	49. B, D	50. C, D
51. A, B, D	52. A, C	53. B, D	54. B, C	55. A, B, C, D
56. B, C	57. A, B, C	58. B, C	59. A, C	60. A, B, C
61. C, D				

Reasoning Based Questions

1. C	2. A	3. C	4. D	5. B	6. D	7. D	8. A	9. A	10. D
11. A	12. A	13. D							

Linked Comprehension Type Questions

1. C	2. C	3. B	4. C	5. C	6. A	7. D	8. B	9. B	10. B
11. A	12. B	13. A	14. D	15. C	16. C	17. D	18. D	19. C	20. D
21. A	22. B	23. A	24. B	25. A	26. D	27. B	28. B	29. C	30. B
31. C	32. A	33. A	34. B	35. B	36. D	37. A	38. B	39. D	40. C
41. B	42. A	43. B	44. C	45. B	46. A	47. D	48. D	49. B	50. B
51. D	52. C	53. A	54. B	55. D	56. C	57. D	58. C	59. B	60. D
61. C	62. A	63. B	64. C	65. A	66. B	67. C	68. D	69. B	70. B
71. B	72. D	73. A	74. C	75. C	76. D	77. D			

Matrix Match/Column Match Type Questions

1. A → (q, t)	B → (r)	C → (s)	D → (p)
2. A → (p, s)	B → (p, r)	C → (q, s)	D → (q, r)
3. A → (p, s)	B → (q, r)	C → (p, r, s)	D → (p, s)
4. A → (r)	B → (s)	C → (p)	D → (q)
5. A → (r)	B → (p)	C → (s)	D → (q)
6. A → (p, s)	B → (r, s)	C → (p, t)	D → (q, t)
7. A → (u)	B → (p, q, t)	C → (s)	D → (r)
8. A → (s)	B → (r)	C → (q)	D → (p)
9. A → (s)	B → (r)	C → (q)	D → (p)
10. A → (p, q, r)	B → (p, r, s)	C → (p, q, r)	D → (p, q, r)
11. A → (s)	B → (r)	C → (q)	D → (t)

2.200 JEE Advanced Physics: Waves and Thermodynamics

Integer/Numerical Answer Type Questions

1. 495	2. 30, 20, 20	3. 972	4. (a) 800, (b) 720	5. 1190	6. 3.96
7. 1830	8. 70	9. 280, 280, 0	10. 36	11. 589	12. (a) 25, (b) 2
13. 80	14. 10	15. 2	16. 20000	17. 60	18. 3
19. 42	20. 2	21. 166	22. 172	23. 384	24. 96
25. 5	26. 6, clockwise	27. 12	28. 40, 500	29. 448	30. 462
31. (a) 9, (b) 80	32. 28	33. 192	34. 40		
35. (a) 600; (b) $Q_{AB} = 3000$, absorbed, $Q_{BC} = 1680$, absorbed, $Q_{CD} = 1800$, released, $Q_{DA} = 1680$, released; (c) 1200					

ARCHIVE: JEE MAIN

1. B	2. D	3. B	4. 20	5. C	6. B	7. A	8. A	9. 266.67	10. 150
11. B	12. C	13. D	14. 41	15. D	16. 5	17. C	18. C	19. B	20. 8791
21. A	22. A	23. D	24. 19.00	25. A	26. A	27. C	28. D	29. 1818.00	30. 46
31. B	32. 60	33. 40	34. B	35. 50	36. B	37. C	38. C	39. C	40. A
41. A	42. D	43. B	44. B	45. B	46. Bonus	47. D	48. B	49. C	50. A
51. A	52. D	53. A	54. B	55. A	56. B	57. A	58. D	59. B	60. C
61. B	62. D	63. C	64. D	65. A	66. A	67. C	68. D	69. C	70. A
71. B	72. B	73. B	74. B	75. B	76. D	77. B	78. B	79. B	80. A
81. D	82. A	83. A	84. C	85. C	86. B	87. D	88. C	89. B	90. C
91. D	92. C	93. D	94. A	95. C	96. D	97. C	98. B	99. A	100. D
101. D	102. C	103. B	104. C	105. B	106. C	107. D	108. B	109. B	110. D
111. D	112. A	113. B	114. C	115. C	116. B	117. B	118. B		

ARCHIVE: JEE ADVANCED

Single Correct Choice Type Questions

1. C	2. B	3. A	4. C	5. A	6. D	7. D	8. C	9. D	10. A
11. C	12. D	13. A	14. C	15. A	16. C	17. C	18. A	19. B	20. C
21. C	22. C	23. None	24. B	25. C	26. C	27. A	28. A	29. A	30. B
31. A	32. B	33. B	34. C	35. A	36. A	37. B	38. D	39. D	40. C
41. D	42. B	43. C	44. A	45. D	46. C	47. C	48. B	49. D	50. B
51. D	52. A	53. B	54. D	55. A	56. B	57. D	58. C	59. A	60. A

Multiple Correct Choice Type Questions

1. B, C, D	2. A, B, C	3. A, B, C	4. C, D	5. B, C, D
6. B, C, D	7. A, B, D	8. A, B, C	9. A, B, C, D	10. A, B, C, D
11. B, D	12. D	13. B, D	14. B, C	15. C, D
16. A, C	17. A, B	18. A, B, D	19. A, B, C, D	

Reasoning Based Questions

1. B

Matrix Match/Column Match Type Questions

1. $A \rightarrow (q, r, s, u)$	$B \rightarrow (q, s, r, u)$	$C \rightarrow (s, r, q, t)$	$D \rightarrow (q, r, p, u)$
2. $A \rightarrow (p, r, t, s)$	$B \rightarrow (p, t, q, t)$	$C \rightarrow (p, r, t, p)$	$D \rightarrow (s, t, q, u)$
3. $A \rightarrow (r)$	$B \rightarrow (s)$	$C \rightarrow (p)$	$D \rightarrow (q)$
4. (C)	5. (B)	6. (B)	
7. $A \rightarrow (s)$	$B \rightarrow (r)$	$C \rightarrow (q)$	$D \rightarrow (p)$
8. $A \rightarrow (p, r, t)$	$B \rightarrow (p, r)$	$C \rightarrow (q, s)$	$D \rightarrow (r, t)$
9. $A \rightarrow (q)$	$B \rightarrow (p, r)$	$C \rightarrow (p, s)$	$D \rightarrow (q, s)$
10. $A \rightarrow (s)$	$B \rightarrow (q)$	$C \rightarrow (p, q)$	$D \rightarrow (q, r)$
11. $A \rightarrow (s)$	$B \rightarrow (p, r)$	$C \rightarrow (p)$	$D \rightarrow (q, s)$

Linked Comprehension Type Questions

1. D	2. D	3. A	4. D	5. C
------	------	------	------	------

Integer/Numerical Answer Type Questions

1. 1.78	2. 6	3. 2.05	4. 8.33	5. 270	6. 4.00	7. 900.00	8. 9	9. 2	10. 2
11. 3	12. 8	13. 9	14. 4	15. 9					