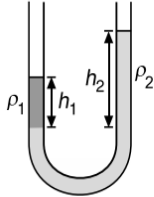

PRACTICE EXERCISES
SINGLE CORRECT CHOICE TYPE QUESTIONS

This section contains Single Correct Choice Type Questions. Each question has four choices (A), (B), (C) and (D), out of which ONLY ONE is correct.

- Capillaries of length l and $2l$ are connected in series. Their radii are r and $2r$ respectively. If stream line flow is maintained and pressure across first and second capillaries are P_1 and P_2 respectively. Then the ratio $\frac{P_1}{P_2}$ will be
 (A) 4 (B) 16
 (C) 8 (D) 32
- A force of 200 N is applied at one end of a wire of length 2 m and having area of cross-section 10^{-2} cm^2 . The other end of the wire is rigidly fixed. If coefficient of linear expansion of the wire $\alpha = 8 \times 10^{-6} \text{ }^\circ\text{C}^{-1}$ and Young's modulus $Y = 2.2 \times 10^{11} \text{ Nm}^{-2}$ and its temperature is increased by $5 \text{ }^\circ\text{C}$, then the increase in the tension of the wire will be
 (A) 4.2 N (B) 4.4 N
 (C) 2.4 N (D) 8.8 N
- Two identical spherical soap bubbles collapse. If V is the consequent change in volume of the contained air, S is the change in the total surface area and T is the surface tension of the soap solution, then (if P is atmospheric pressure and assume temperature to remain same in all the bubbles).
 (A) $3PV + 4ST = 0$
 (B) $4PV + 3ST = 0$
 (C) $PV + 4TS = 0$
 (D) $4PV + ST = 0$
- Two wires of the same material have diameters in the ratio 2:1 and lengths in the ratio 1:2. If they are stretched by the same force, their elongations will be in the ratio
 (A) 8:1 (B) 1:8
 (C) 2:1 (D) 1:4
- A ball of density ρ is released from deep inside of a liquid of density 2ρ . It will move up
 (A) with an increasing acceleration
 (B) with a decreasing acceleration
 (C) with a constant acceleration
 (D) with zero acceleration
- A cylinder with a movable piston contains air under a pressure P_1 and a soap bubble of radius r . The pressure P_2 to which the air should be compressed by slowly pushing the piston into the cylinder for the soap bubble to reduce its size by half will be (The surface tension is T and the temperature is maintained constant).
 (A) $8P_1 + \frac{24T}{r}$ (B) $4P_1 + \frac{24T}{r}$
 (C) $2P_1 + \frac{24T}{r}$ (D) $2P_1 + \frac{24T}{r}$
- A steel rod of length l , area of cross-section A , Young's modulus Y and coefficient of linear expansion α is heated through $t \text{ }^\circ\text{C}$. The work that can be performed by a rod when heated is
 (A) $(YA\alpha t)(l\alpha t)$ (B) $\frac{1}{2}(YA\alpha t)(l\alpha t)$
 (C) $\frac{1}{2}(YA\alpha t)\left(\frac{1}{2}l\alpha t\right)$ (D) $2(YA\alpha t)(l\alpha t)$
- An ice cube of size $a = 10 \text{ cm}$ is floating in a tank (base area $A = 50 \text{ cm} \times 50 \text{ cm}$) partially filled with water. The change in gravitational potential energy, when ice melts completely is: (density of ice is 900 kgm^{-3})
 (A) -0.072 J (B) -0.24 J
 (C) -0.016 J (D) -0.045 J
- Two liquids which do not react chemically are placed in a bent tube as shown in Figure.

 The heights of the liquids above their surface of separation are
 (A) directly proportional to their densities
 (B) inversely proportional to their densities
 (C) directly proportional to square of their densities
 (D) equal
- A thin metal ring of internal radius 8 cm and external radius 9 cm is supported horizontally from the pan of a balance so that it comes in contact with water in a glass vessel, if is found that an extra weight of 7.48 g is required to pull the ring out of water. The surface tension of water is ($g = 10 \text{ ms}^{-2}$)
 (A) $80 \times 10^{-3} \text{ Nm}^{-1}$ (B) $25 \times 10^{-3} \text{ Nm}^{-1}$
 (C) $45 \times 10^{-3} \text{ Nm}^{-1}$ (D) $70 \times 10^{-3} \text{ Nm}^{-1}$
- A boy's catapult is made of rubber cord which is 42 cm long, with 6 mm diameter of cross-section and of negligible mass. The boy keeps a stone weighing 0.02 kg on it and stretches the cord by 20 cm by applying a constant force. When released, the stone flies off with a velocity of 20 ms^{-1} . Neglect the change in the area of cross-section of the cord while stretched. The Young's modulus of rubber is closest to

- (A) 10^4 Nm^{-2} (B) 10^3 Nm^{-2}
 (C) 10^8 Nm^{-2} (D) 10^6 Nm^{-2}
12. A metallic wire of density ρ floats horizontal in water. The maximum radius of the wire so that the wire may not sink will be (if surface tension of water is T and angle of contact is 0°)
- (A) $\sqrt{\frac{2T}{\pi\rho g}}$ (B) $\sqrt{\frac{4T}{\rho g}}$
 (C) $\sqrt{\frac{T}{\pi\rho g}}$ (D) $\sqrt{\frac{T\rho}{\pi g}}$

13. A soap bubble of radius r is placed on another bubble of radius $2r$. The radius of the surface common to both the bubbles is
- (A) $\frac{2r}{3}$ (B) $3r$
 (C) $2r$ (D) r
14. Young's moduli of two wires A and B are in the ratio $7:4$. Wire A is 2 m long and has radius R . Wire B is 1.5 m long and has radius 2 mm . If the two wires stretch by the same length for a given load, then the value of R is close to
- (A) 1.3 mm (B) 1.9 mm
 (C) 1.5 mm (D) 1.7 mm

15. A cylindrical vessel of area of cross-section A is filled with water (density ρ) to a height H . It has capillary tube of length l and radius r fitted horizontally at its bottom. If the coefficient of viscosity of water is η , then time in which level will fall to a height $\frac{H}{2}$ is
- (A) $\frac{\eta l r^2}{4A\rho} \ln(2)$ (B) $\frac{4\eta l r^4}{\pi g A \rho} \ln\left(\frac{1}{2}\right)$
 (C) $\frac{8\eta l A}{\rho \pi g r^4} \ln(2)$ (D) $\frac{4H\eta l \rho}{\pi g r^4} \ln(2)$

16. A brass rod of cross-sectional area 1 cm^2 and length 0.2 m is compressed lengthwise by a weight of 5 kg . If Young's modulus of elasticity of brass is $1 \times 10^{11} \text{ Nm}^{-2}$ and $g = 10 \text{ ms}^{-2}$, then increase in the energy of the rod will be
- (A) 10^{-5} J (B) $2.5 \times 10^{-5} \text{ J}$
 (C) $5 \times 10^{-5} \text{ J}$ (D) $2.5 \times 10^{-4} \text{ J}$

17. The height of mercury barometer is h when the atmospheric pressure is 10^5 Pa . The pressure at x in the shown diagram is

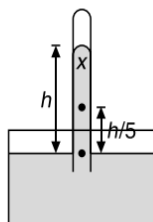

- (A) 10^5 Pa (B) $0.8 \times 10^5 \text{ Pa}$
 (C) $0.2 \times 10^5 \text{ Pa}$ (D) $120 \times 10^5 \text{ Pa}$

18. An ice cube is floating in water above which a layer of lighter oil is poured. As the ice melts completely, the level of interface and the upper most level of oil will respectively

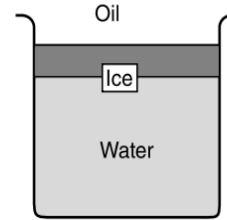

- (A) rise and fall
 (B) fall and rise
 (C) not change and not change
 (D) not change and fall
19. A thin uniform circular tube is kept in a vertical plane. Equal volumes of two immiscible liquids whose densities are ρ_1 and ρ_2 fill half of the tube. In equilibrium the radius passing through the interface makes an angle of $\theta = 30^\circ$ with vertical as shown in Figure. The ratio of densities $\left(\frac{\rho_1}{\rho_2}\right)$ is equal to

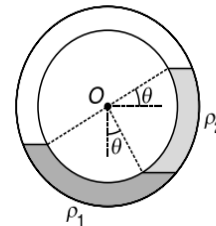

- (A) $\frac{\sqrt{3}-1}{2-\sqrt{3}}$ (B) $\frac{\sqrt{3}+1}{2+\sqrt{3}}$
 (C) $\frac{\sqrt{3}-1}{\sqrt{3}+1}$ (D) $\frac{\sqrt{3}+1}{\sqrt{3}-1}$
20. The terminal velocity of a ball (of density ρ) in air (of density σ) is v , where acceleration due to gravity is g . Now the same ball is taken in a gravity free space where all other conditions are same. The ball is now given the same velocity v , then for $\rho = 2\sigma$
- (A) the terminal velocity of the ball will be $\frac{v}{2}$
 (B) the ball will move with a constant velocity
 (C) the initial acceleration of the ball is $2g$ in direction opposite to the ball's velocity
 (D) the ball will finally stop
21. A massless spring ($k = 800 \text{ Nm}^{-1}$), attached with a mass (500 g) is completely immersed in 1 kg of water. The spring is stretched by 2 cm and release so that it starts vibrating. What would be the order of magnitude of the change in the temperature of water when the vibrations stop completely? (Assume that the water container and spring receive negligible heat and specific heat of mass is $400 \text{ Jkg}^{-1}\text{K}^{-1}$, specific heat of water is $4184 \text{ Jkg}^{-1}\text{K}^{-1}$)
- (A) 10^{-5} K (B) 10^{-1} K
 (C) 10^{-3} K (D) 10^{-4} K

1.134 JEE Advanced Physics: Waves and Thermodynamics

22. A ball of relative density 0.8 falls into water from a height of 2 m. The depth to which the ball will sink (if viscous forces are neglected) is
 (A) 8 m (B) 2 m
 (C) 6 m (D) 4 m
23. Water is filled in a symmetrical container as shown in Figure.

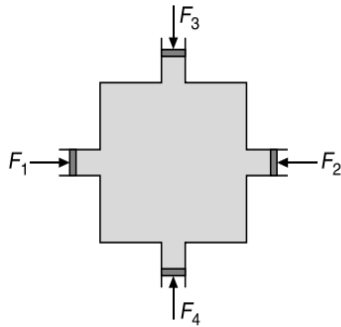

Four pistons each of area A are used at the four openings to keep the water in equilibrium. Now an additional force each of magnitude F is applied at each piston. The increase in the pressure at the centre of the container due to this additional force is

- (A) $\frac{F}{A}$ (B) $\frac{2F}{A}$
 (C) $\frac{4F}{A}$ (D) 0
24. Three capillary tubes of same radius 1 cm but of lengths 1 m, 2 m and 3 m are fitted horizontally to the bottom of a long cylinder containing a liquid at constant pressure and flowing through these tubes. What is the length of a single tube which can replace the three capillaries?
 (A) $\frac{6}{11}$ m (B) 6 m
 (C) 5 m (D) None of these
25. If a million tiny droplets of water of the same radius coalesce into one larger drop the ratio of the surface energy of the large drop to the total surface energy of all the droplets will be
 (A) 1:10 (B) 1:10²
 (C) 1:10⁴ (D) 1:10⁶
26. The cubical container $ABCDEFGH$ which is completely filled with an ideal (non-viscous and incompressible) fluid, moves in a gravity free space with an acceleration of $a = a_0(\hat{i} - \hat{j} + \hat{k})$ where a_0 is a positive constant. Then the only point in the container where pressure can be zero is

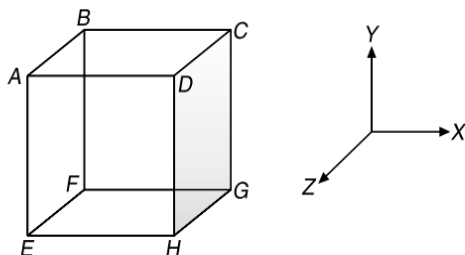

- (A) B (B) C
 (C) E (D) H

27. A uniform plank of Young's modulus Y is moved over a smooth horizontal surface by a constant horizontal force F . The area of cross section of the plank is A . The strain on the plank in the direction of the force is
 (A) $\frac{F}{AY}$ (B) $\frac{2F}{AY}$
 (C) $\frac{1}{2}\left(\frac{F}{AY}\right)$ (D) $\frac{3F}{AY}$

28. The strain-stress curves of three wires of different materials are shown in Figure.

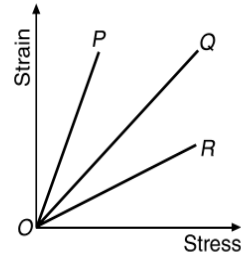

P , Q and R are the elastic limits of the wires. The figure shows that

- (A) Elasticity of wire P is maximum
 (B) Elasticity of wire Q is maximum
 (C) Tensile strength of R is maximum
 (D) None of the above is true
29. A cylinder of mass m and density ρ hanging from a string is lowered into a vessel of cross-sectional area s containing a liquid of density $\sigma (< \rho)$ until it is fully immersed. The increase in pressure at the bottom of the vessel is
 (A) $\frac{m\rho g}{\sigma s}$ (B) $\frac{mg}{s}$
 (C) $\frac{m\sigma g}{\rho s}$ (D) ZERO
30. The elastic limit of brass is 379 MPa. What should be the minimum diameter of a brass rod if it is to support a 400 N load without exceeding its elastic limit?
 (A) 0.90 mm (B) 1.16 mm
 (C) 1.00 mm (D) 1.36 mm
31. The viscous force on a liquid passing through a length L of pipe in laminar flow is given by $F = 4\pi\eta Lv_m$ where η is the liquid viscosity and v_m is the maximum velocity of the liquid (i.e., along the central axis of the pipe). If pressure difference at the two ends of the pipe (of radius r) is ΔP , then v_m is equal to
 (A) $\frac{4\eta\Delta P}{r^2L}$ (B) $\frac{(\Delta P)r^2}{4\eta L}$
 (C) $\frac{(\Delta P)L}{4\eta r^2}$ (D) $\frac{\Delta P}{4\eta Lr^2}$
32. The elastic deformation energy per unit volume in fresh water (of density d) of compressibility β at a depth h below the surface is
 (A) $\frac{1}{2}\beta(hdg)^2$ (B) $\frac{(hdg)^2}{2\beta}$
 (C) $\frac{1}{2}\beta(hdg)$ (D) $\beta(hdg)^2$

33. A capillary tube of radius r is immersed in water and water rises in it to a height h . The mass of the water in the capillary tube is m . Another capillary of radius $2r$ is immersed in water. The mass of water that will rise in this tube is

- (A) $\frac{m}{2}$ (B) m
(C) $2m$ (D) $4m$

34. A material has Poisson's ratio 0.20. If a uniform rod of it suffers a longitudinal strain of 2×10^{-3} , then the percentage change in volume is

- (A) +0.12 (B) -0.12
(C) +0.28 (D) -0.28

35. A wire of cross-sectional area 3 mm^2 is first stretched between two fixed points at a temperature of 20°C . Determine the tension when the temperature falls to 10°C . Coefficient of linear expansion $\alpha = 10^{-5} \text{ }^\circ\text{C}^{-1}$ and $Y = 2 \times 10^{11} \text{ Nm}^{-2}$

- (A) 20 N (B) 30 N
(C) 60 N (D) 120 N

36. If ρ is the density of the material of a wire and σ the breaking stress. The greatest length of the wire that can hang freely without breaking is

- (A) $\frac{2\sigma}{\rho g}$ (B) $\frac{\rho}{\sigma g}$
(C) $\frac{\rho g}{2\sigma}$ (D) $\frac{\sigma}{\rho g}$

37. A uniform cylindrical rod of length L and radius r , is made from a material whose Young's modulus of Elasticity equals Y . When this rod is heated by temperature T and simultaneously subjected to a net longitudinal compressional force F , its length remains unchanged. The coefficient of volume expansion, of the material of the rod, is (nearly) equal to

- (A) $\frac{9F}{(\pi r^2 Y T)}$ (B) $\frac{3F}{(\pi r^2 Y T)}$
(C) $\frac{F}{(\pi r^2 Y T)}$ (D) $\frac{6F}{(\pi r^2 Y T)}$

38. A block of volume V and density ρ is floating in a liquid of density 2ρ filled in a vessel. Now the vessel starts falling freely with acceleration g . Then the volume of block inside the liquid in the following condition is

- (A) V (B) $\frac{1}{2}V$
(C) arbitrary (D) ZERO

39. A cylindrical wooden float having base area A and the height H drifts on the water surface. If density of wood is d and density of water is ρ then calculate the minimum work performed to take the float out of the water (ignore surface tension) is

- (A) $\frac{A^2 g d}{2\rho}$ (B) $\frac{A g d^2 H^2}{\rho}$
(C) $\frac{A g d^2 H^2}{2\rho}$ (D) $\frac{2 A^3 g d^2}{\rho H^2}$

40. A ball of mass m and density ρ is immersed in a liquid of density 3ρ at a depth h and released. To what height will the ball jump up above the surface of liquid? (neglect the resistance of water and air).

- (A) h (B) $\frac{h}{2}$
(C) $2h$ (D) $3h$

41. A large block of ice cuboid of edge length l and density $\rho_{\text{ice}} = 0.9\rho_w$, has a large vertical hole along its axis. This block is floating in a lake. The minimum length of the rope required to raise a bucket of water through the hole is

- (A) $\frac{l}{2}$ (B) $\frac{l}{4}$
(C) $\frac{l}{8}$ (D) $\frac{l}{10}$

42. The pressure inside two soap bubbles is 1.01 and 1.02 atmosphere. The ratio of their respective volumes is

- (A) 8 (B) 4
(C) 16 (D) 2

43. A small hole is made at the bottom of a symmetrical jar as shown in Figure. A liquid is filled into the jar upto a certain height. The rate of descent of liquid is independent of the level of liquid in the jar. Then the surface of jar is a surface of revolution of the curve

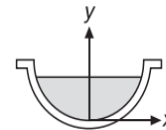

- (A) $y = kx^4$ (B) $y = kx^2$
(C) $y = kx^3$ (D) $y = kx^5$

44. A glass rod of radius 1 m is inserted symmetrically into a glass capillary tube with inside radius 2 mm. Then the whole arrangement is brought in contact of the surface of water. Surface tension of water is $7 \times 10^{-2} \text{ Nm}^{-1}$. To what height will the water rise in the capillary: ($\theta = 0^\circ$)

- (A) 1.4 cm (B) 4.2 cm
(C) 2.1 cm (D) 6.8 cm

45. The volume flow rate of an ideal liquid in m^3s^{-1} at certain time and its direction at various points of a pipe is shown in Figure.

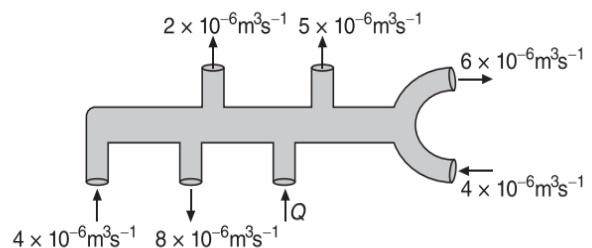

The value of Q in m^3s^{-1} is (Assume steady state and equal area of cross section at each opening)

- (A) 10×10^{-6} (B) 11×10^{-6}
(C) 13×10^{-6} (D) 18×10^{-6}

1.136 JEE Advanced Physics: Waves and Thermodynamics

46. A vessel containing water is given a constant acceleration a towards the right along a straight horizontal path. Which of the following diagrams represents the surface of the liquid?

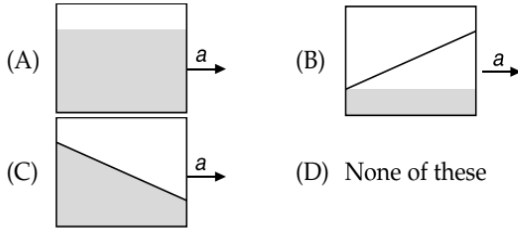

47. A load of mass M kg is suspended from a steel wire of length 2 m and radius 1.0 mm in Searle's apparatus experiment. The increase in length produced in the wire is 4.0 mm. Now the load is fully immersed in a liquid of relative density 2. The relative density of the material of the load is 8.

The new value of increase in length of the steel wire is

- (A) 4.0 mm (B) ZERO
(C) 5.0 mm (D) 3.0 mm
48. A cubical block of wood of specific gravity 0.5 and chunk of concrete of specific gravity 2.5 are fastened together. The ratio of mass of concrete to the mass of wood which makes the combination to float with its entire volume submerged in water is
- (A) $\frac{5}{3}$ (B) $\frac{5}{1}$
(C) $\frac{5}{2}$ (D) $\frac{4}{3}$
49. A small steel ball falls through a syrup at a constant speed of 1 ms^{-1} . If the steel ball is pulled upwards with a force equal to twice its effective weight, how fast will it move upward?
- (A) 1 ms^{-1} (B) 2 ms^{-1}
(C) 0.5 ms^{-1} (D) ZERO

50. A submarine experiences a pressure of $5.05 \times 10^6 \text{ Pa}$ at a depth of d_1 in a sea. When it goes further to a depth of d_2 , it experiences a pressure of $8.08 \times 10^6 \text{ Pa}$. Then $d_2 - d_1$ is approximately (density of water = 10^3 kgm^{-3} and acceleration due to gravity = 10 ms^{-2})

- (A) 600 m (B) 500 m
(C) 300 m (D) 400 m

51. A U-tube of uniform cross-section filled with two immiscible liquids as shown in Figure. One is water with density ρ_w and the other liquid is of density ρ . The liquid interface lies 2 cm above the base. The relation between ρ and ρ_w is

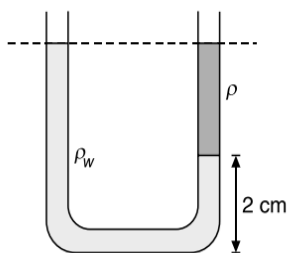

- (A) $\rho = \rho_w$ (B) $\rho = 1.02\rho_w$
(C) $\rho = 1.2\rho_w$ (D) $\rho = \frac{\rho_w}{2}$

52. If viscosity of air is taken into account, then the orbital speed of the satellite moving close to earth

- (A) increases till the satellite falls back on the earth
(B) increases till the satellite overcomes earth's gravitational pull
(C) decrease continuously
(D) remains unaffected

53. A spring balance reads 10 kg when a bucket of water is suspended from it. The reading of the balance when an iron piece of mass 7.2 kg suspended by a string is immersed with half its volume inside the water in the bucket (Relative density of iron is 7.2) is

- (A) 10 kg (B) 10.5 kg
(C) 13.6 kg (D) 17.2 kg

54. A water hose pipe of cross-sectional area 5 cm^2 is used to fill a tank of 120 L. It has been observed that it takes 2 min to fill the tank. Now, a nozzle with an opening of cross-sectional area 1 cm^2 is attached to the hose. The nozzle is held so that water is projected horizontally from a point 1 m above the ground. The horizontal distance over which the water can be projected is (Take $g = 10 \text{ ms}^{-2}$)

- (A) 3 m (B) 8 m
(C) 4.47 m (D) 8.64 m

55. A U-tube of base length l filled with same volume of two liquids of densities ρ and 2ρ is moving with an acceleration a on the horizontal plane. If the height difference between the two surfaces (open to atmosphere) becomes zero, then the height h is given by

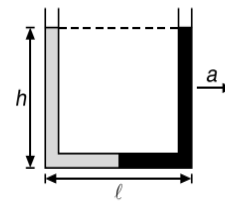

- (A) $\left(\frac{a}{2g}\right)l$ (B) $\left(\frac{3a}{2g}\right)l$
(C) $\left(\frac{a}{g}\right)l$ (D) $\left(\frac{2a}{3g}\right)l$

56. Consider the barometer shown in Figure.

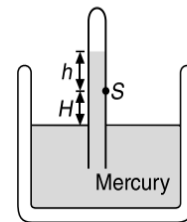

A small hole is made at point S as shown. The mercury (of density ρ) comes out from this hole with speed v equal to

- (A) $\sqrt{2gh}$ (B) $\sqrt{2gH}$
(C) $\sqrt{2g(H-h)}$ (D) None of these

57. An ideal fluid is flowing through the given tubes of diameter d and $2d$ which is placed on a horizontal surface. If the liquid has velocities v_A and v_B and pressures P_A and P_B at points A and B respectively, then the correct relation is (A and B are at same height from ground level)

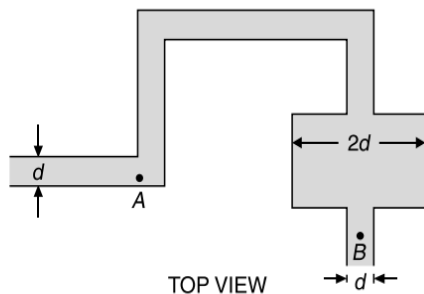

- (A) $v_A > v_B, P_A < P_B$ (B) $v_A < v_B, P_A > P_B$
 (C) $v_A = v_B, P_A = P_B$ (D) $v_A > v_B, P_A = P_B$
58. To measure the atmospheric pressure, four different tubes of length 1 m, 2 m, 3 m and 4 m are used. If the height of the mercury column in the tubes is h_1, h_2, h_3, h_4 respectively in the four cases, then $h_1 : h_2 : h_3 : h_4$ is
- (A) 1 : 2 : 3 : 4 (B) 4 : 3 : 2 : 1
 (C) 1 : 2 : 2 : 1 (D) 1 : 1 : 1 : 1
59. The amount of work done in forming a soap bubble of radius $r = 1$ cm having surface tension $T = 3 \times 10^{-2} \text{ Nm}^{-1}$ is
- (A) 37.38 μJ (B) 40.20 μJ
 (C) 75.36 μJ (D) 20.10 μJ
60. One end of a glass capillary tube with a radius $r = 0.005$ cm is immersed into water to a depth of $h = 2$ cm. The pressure is required to blow an air bubble out of the lower end of the tube. If $T = 7 \times 10^{-2} \text{ Nm}^{-1}$ and $\rho = 10^3 \text{ kgm}^{-3}$ is
- (A) 480 Nm^{-2} (B) 680 Nm^{-2}
 (C) 120 Nm^{-2} (D) 820 Nm^{-2}
61. The length of a rubber cord is L_1 metres when the tension is 4 N and L_2 metres when the tension is 5 N. The length in metres when the tension is 9 N is
- (A) $5L_1 - 4L_2$ (B) $5L_2 - 4L_1$
 (C) $9L_1 - 8L_2$ (D) $9L_2 - 8L_1$
62. Young's modulus of steel is $2 \times 10^{11} \text{ Nm}^{-2}$. A steel wire has a length of 1 m and area of cross section 1 mm^2 . The work required to increase its length by 1 mm is
- (A) 0.1 J (B) 1 J
 (C) 10 J (D) 100 J
63. Bulk modulus of water is $2 \times 10^9 \text{ Nm}^{-2}$. The change in pressure required to increase the density of water by 0.1% is
- (A) $2 \times 10^9 \text{ Nm}^{-2}$ (B) $2 \times 10^8 \text{ Nm}^{-2}$
 (C) $2 \times 10^6 \text{ Nm}^{-2}$ (D) $2 \times 10^4 \text{ Nm}^{-2}$
64. A rod of length ℓ and radius r is joined to a rod of length $\frac{\ell}{2}$ and radius $\frac{r}{2}$ of same material. The free end of small rod is fixed to a rigid base and the free end of larger rod is given a twist of θ° , the twist angle at the joint will be

- (A) $\frac{\theta}{4}$ (B) $\frac{\theta}{2}$
 (C) $\frac{5\theta}{6}$ (D) $\frac{8\theta}{9}$

65. There is a horizontal film of soap solution. On it a thread is placed in the form of a loop. The film is pierced inside the loop and the thread becomes a circular loop of radius R . If the surface tension of the loop be T , then tension in the thread will be
- (A) $\pi R^2 T$ (B) $2RT$
 (C) RT (D) $\frac{\pi R^2}{T}$
66. A body of density ρ is dropped from rest from a height h into a lake of density σ ($\sigma > \rho$). The maximum depth the body sinks inside the liquid is (neglect viscous effect of liquid)
- (A) $\frac{h\rho}{\sigma - \rho}$ (B) $\frac{h\sigma}{\sigma - \rho}$
 (C) $\frac{h\rho}{\sigma}$ (D) $\frac{h\sigma}{\rho}$
67. If the volume of the given mass of a gas is increased four times, the temperature is raised from 27°C to 127°C . The elasticity will become
- (A) 4 times (B) $\frac{1}{4}$ times
 (C) 3 times (D) $\frac{1}{3}$ times
68. A satellite revolves round the earth. Air pressure inside the satellite is maintained at 76 cm of mercury. The height of mercury column in a barometer tube 90 cm long placed in the satellite is
- (A) 76 cm (B) 90 cm
 (C) ZERO (D) can be any of these
69. A material has Poisson's ratio 0.5. If a uniform rod of it suffers a longitudinal strain of 2×10^{-3} , the percentage increase in its volume is
- (A) 1 (B) 1.5
 (C) 0.5 (D) 0
70. A metallic rod of Young's modulus $2 \times 10^{11} \text{ Nm}^{-2}$ undergoes a strain of 0.5%. Then the energy stored per unit volume in the rod will be
- (A) $2.5 \times 10^6 \text{ Jm}^{-3}$
 (B) $5 \times 10^8 \text{ Jm}^{-3}$
 (C) $2.5 \times 10^8 \text{ Jm}^{-3}$
 (D) $0.5 \times 10^{11} \text{ Jm}^{-3}$
71. Two wires A and B have the same length and area of cross section. But Young's modulus of A is two times the Young's modulus of B . Then the ratio of force constant of A to that of B is
- (A) 1 (B) 2
 (C) $\frac{1}{2}$ (D) $\sqrt{2}$

1.138 JEE Advanced Physics: Waves and Thermodynamics

72. A liquid stands at the plane level in the U-tube when at rest. If areas of cross-section of both the limbs are equal. The difference in heights h of the liquid in the two limbs of U-tube, when the system is given an acceleration a in horizontal direction towards right as shown in Figure is

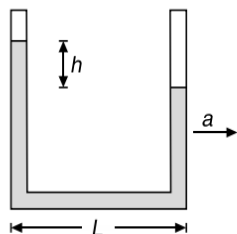

- (A) $\frac{Lg}{a}$ (B) $\frac{La}{g}$
 (C) $\frac{Lg^2}{a^2}$ (D) ZERO
73. Water from a pipe is coming at a rate of 100 liters per minute. If the radius of the pipe is 5 cm, the Reynolds number for the flow is of the order of (if density of water is 1000 kgm^{-3} , coefficient of viscosity of water is 1 mPas)
- (A) 10^2 (B) 10^4
 (C) 10^3 (D) 10^6
74. In case of a liquid
- (A) only bulk modulus is defined
 (B) only bulk modulus and Young's modulus are defined
 (C) only bulk modulus and shear modulus are defined
 (D) all the three moduli (bulk, Young's and shear) are defined
75. The top of a water tank is open to air and its water level is maintained. It is giving out 0.74 m^3 water per minute through a circular opening of 2 cm radius in its wall. The depth of the centre of the opening from the level of water in the tank is close to
- (A) 9.6 m (B) 2.9 m
 (C) 4.8 m (D) 6.0 m
76. If the ratio of lengths, radii and Young's moduli of steel and brass wires in the figure are a , b and c respectively. Then the corresponding ratio of increase in their lengths would be

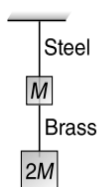

- (A) $\frac{2a^2c}{b}$ (B) $\frac{3a}{2b^2c}$
 (C) $\frac{2ac}{b^2}$ (D) $\frac{3c}{2ab^2}$
77. A wooden block floating in a bucket of water has $\frac{4}{5}$ of its volume submerged. When certain amount of an oil is poured into the bucket, it is found that the block is just under the oil

surface with half of its volume under water and half in oil. The density of oil relative to that of water is

(A) 0.5 (B) 0.8
 (C) 0.7 (D) 0.6

78. A wooden cube floating in water supports a mass $m = 0.2 \text{ kg}$ on its top. When the mass is removed the cube rises by 2 cm. The side of the cube is (density of water = 10^3 kgm^{-3})
- (A) 6 cm (B) 12 cm
 (C) 8 cm (D) 10 cm
79. A solid sphere, of radius R acquires a terminal velocity v_1 when falling (due to gravity) through a viscous fluid having a coefficient of viscosity η . The sphere is broken into 27 identical solid spheres. If each of these spheres acquires a terminal velocity, v_2 , when falling through the same fluid, the ratio $\left(\frac{v_1}{v_2}\right)$ equals
- (A) $\frac{1}{27}$ (B) 9
 (C) $\frac{1}{9}$ (D) 27
80. Two cylinders of same cross-section and length L but made of two material of densities d_1 and d_2 are cemented together to form a cylinder of length $2L$. The combination floats in a liquid of density d with a length $\frac{L}{2}$ above the surface of the liquid. If $d_1 < d_2$ then
- (A) $d_1 < \frac{3}{4}d$ (B) $\frac{d}{2} > 4$
 (C) $\frac{d}{4} > d$ (D) $d < d$
81. A body floats in completely immersed condition in water as shown in Figure. When the whole system is allowed to slide down freely along the inclined surface, the magnitude of buoyant force

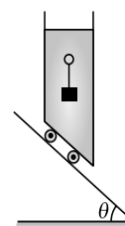

- (A) remains unchanged (B) increases
 (C) decreases (D) becomes zero
82. A soap bubble of radius r is placed on another bubble of radius $2r$. The angles formed between the films (of soap bubbles) at the points of contact are
- (A) $60^\circ, 60^\circ, 60^\circ$ (B) $45^\circ, 60^\circ, 90^\circ$
 (C) $30^\circ, 60^\circ, 90^\circ$ (D) $120^\circ, 120^\circ, 120^\circ$
83. A uniform rod OB of length 1 m, cross-sectional area 0.012 m^2 and relative density 2.0 is free to rotate about O in vertical plane. The rod is held with a horizontal string AB which can withstand a maximum tension of 45 N. The rod and string system is kept in water as shown in Figure. The

maximum value of angle α which the rod can make with vertical without breaking the string is (Take $g = 10 \text{ ms}^{-2}$)

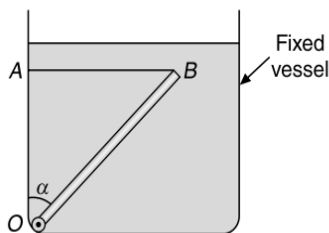

- (A) 45° (B) 37°
(C) 53° (D) 60°

84. A barometer tube reads 76 cm of mercury. If the tube is gradually inclined at an angle of 60° with vertical, keeping the open end immersed in the mercury reservoir, the length of the mercury column will be
(A) 152 cm (B) 76 cm
(C) 38 cm (D) $38\sqrt{3}$ cm

85. One end of a long iron chain of linear mass density λ is fixed to a sphere of mass m and specific density $\frac{1}{3}$ while the other end is free. The sphere along with the chain is immersed in a deep lake. If specific density of iron is 7, the height h above the bed of the lake at which the sphere will float in equilibrium is (Assume that the part of the chain lying on the bottom of the lake exerts negligible force on the upper part of the chain)

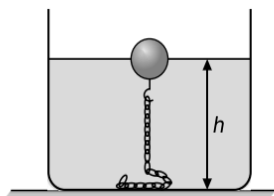

- (A) $\frac{5m}{2\lambda}$ (B) $\frac{7m}{3\lambda}$
(C) $\frac{8m}{3\lambda}$ (D) $\frac{16m}{7\lambda}$

86. Two identical cylindrical vessels with their bases at the same level, each contains a liquid of density ρ . The height of the liquid in one vessel is h_1 and that in the other is h_2 . The area of either base is A . The work done by gravity in equalizing the levels when the vessels are interconnected is
(A) $A\rho g\left(\frac{h_1-h_2}{2}\right)$ (B) $A\rho g\left(\frac{h_1-h_2}{2}\right)^2$
(C) $A\rho g\left(\frac{h_1-h_2}{4}\right)$ (D) $A\rho g\left(\frac{h_1-h_2}{4}\right)^2$
87. A rubber cord of length L is suspended vertically. Density of rubber is D and Young's modulus is Y . If the cord extends by a length ℓ under its own weight, then

- (A) $\ell = \frac{L^2 Dg}{Y}$ (B) $\ell = \frac{L^2 Dg}{2Y}$
(C) $\ell = \frac{L^2 Dg}{4Y}$ (D) $\ell = \frac{L^2 Dg}{8Y}$

88. The diagram shows a force-extension graph for a rubber band. Consider the following statements

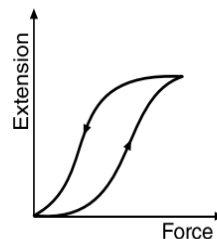

- (I) It will be easier to compress this rubber than expand it
(II) Rubber does not return to its original length after it is stretched
(III) The rubber band will get heated if it is stretched and released

Which of these can be deduced from the graph?

- (A) III only (B) II and III
(C) I and III (D) I only

89. A large tank is filled with water having density $\rho_w = 10^3 \text{ kgm}^{-3}$. A small hole is made at a depth 10 m below water surface. The range of water coming out of the hole is R on ground. The extra pressure that must be applied on the water surface so that the range becomes $2R$ (If $1 \text{ atm} = 10^5 \text{ Pa}$ and $g = 10 \text{ ms}^{-2}$) is
(A) 9 atm (B) 4 atm
(C) 5 atm (D) 3 atm

90. If a rubber ball is taken at the depth of 200 m in a pool, its volume decreases by 0.1%. If the density of the water is $1 \times 10^3 \text{ kgm}^{-3}$ and $g = 10 \text{ ms}^{-2}$, then the volume elasticity in Nm^{-2} will be
(A) 10^8 (B) 2×10^8
(C) 10^9 (D) 2×10^9

91. A weight of 200 kg is suspended by vertical wire of length 600.5 cm. The area of cross-section of wire is 1 mm^2 . When the load is removed, the wire contracts by 0.5 cm. The Young's modulus of the material of wire will be
(A) $2.35 \times 10^{12} \text{ Nm}^{-2}$ (B) $1.35 \times 10^{10} \text{ Nm}^{-2}$
(C) $13.5 \times 10^{11} \text{ Nm}^{-2}$ (D) $23.5 \times 10^9 \text{ Nm}^{-2}$

92. When a force is applied on a wire of uniform cross-sectional area $3 \times 10^{-6} \text{ m}^2$ and length 4 m, the increase in length is 1 mm. Energy stored in it will be ($Y = 2 \times 10^{11} \text{ Nm}^{-2}$)
(A) 6250 J (B) 0.177 J
(C) 0.075 J (D) 0.150 J

93. The mean density of sea water is ρ , and bulk modulus is B . The change in density of sea water in going from the surface of water to a depth of h is
(A) $\frac{B\rho^2}{gh}$ (B) $B\rho gh$
(C) $\frac{\rho^2 gh}{B}$ (D) $\frac{\rho gh}{B}$

94. A liquid of density ρ is coming out of a hose pipe of radius a with horizontal speed v and hits a mesh. 50% of the liquid passes through the mesh unaffected. 25% loses all of its momentum and 25% comes back with the same speed. The resultant pressure on the mesh will be

1.140 JEE Advanced Physics: Waves and Thermodynamics

- (A) $\frac{3}{4}\rho v^2$ (B) $\frac{1}{4}\rho v^2$
 (C) $\frac{1}{2}\rho v^2$ (D) ρv^2

95. A cubical block of side 10 cm floats at the interface of an oil and water as shown in Figure. The density of oil is 0.6 g cm^{-3} and the lower face of ice cube is 2 cm below the interface. The pressure above that of the atmosphere at the lower face of the block is

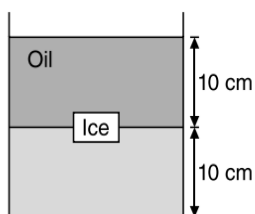

- (A) 200 Pa (B) 620 Pa
 (C) 900 Pa (D) 800 Pa

96. A cubical block of side 0.5 m floats on water with 30% of its volume under water. What is the maximum weight that can be put on the block without fully submerging it under water? (Take, density of water = 10^3 kg m^{-3})

- (A) 30.1 kg (B) 46.3 kg
 (C) 87.5 kg (D) 65.4 kg

97. A rubber balloon has 200 g of water in it. Its weight in water will be (neglect the weight of balloon)

- (A) 100 g (B) 200 g
 (C) 50 g (D) ZERO

98. A body floats in water with its one-third volume above the surface. The same body floats in a liquid with one-third volume immersed. The density of the liquid is

- (A) 9 times more than that of water
 (B) 2 times more than that of water
 (C) 3 times more than that of water
 (D) 1.5 times more than that of water

99. A flat plate of area 20 cm^2 is placed on a horizontal surface coated with a layer of glycerine 1 mm thick. What force must be applied to the plate to keep it moving with a speed of 1 cm s^{-1} over the horizontal surface? (Coefficient of viscosity of glycerine = $2 \text{ kg m}^{-1} \text{ s}^{-1}$)

- (A) $2 \times 10^{-3} \text{ N}$ (B) 2 N
 (C) $1 \times 10^{-4} \text{ N}$ (D) $4 \times 10^{-2} \text{ N}$

100. An open vessel full of water is falling freely under gravity. There is a small hole in one face of the vessel as shown in Figure. The water which comes out from the hole at the instant when hole is at height H above the ground, strikes the ground at a distance of x from P . Which of the following is correct for the situation described?

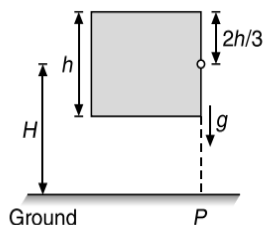

(A) The value of x is $2\sqrt{\frac{2hH}{3}}$.

(B) The value of x is $\sqrt{\frac{4hH}{3}}$.

(C) The value of x can't be computed from information provided.

(D) No water comes out from the hole.

101. A block of mass 2 kg and specific gravity $\frac{5}{2}$ is attached with a spring of force constant $k = 100 \text{ Nm}^{-1}$ and is half dipped in the water. If extension in the spring is 1 cm. The force exerted by the bottom of the tank on block is (take $g = 10 \text{ ms}^{-2}$)

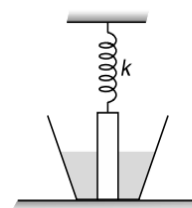

- (A) 20 N (B) 19 N
 (C) 15 N (D) 16 N

102. A leakage begins in water tank at position P as shown in Figure. The initial gauge pressure (pressure above that of the atmosphere) at P was $5 \times 10^5 \text{ Nm}^{-2}$. If the density of water is 1000 kg m^{-3} the initial velocity with which water gushes out is approximately



- (A) 3.2 ms^{-1} (B) 32 ms^{-1}
 (C) 28 ms^{-1} (D) 2.8 ms^{-1}

103. A non-uniform cylinder of mass m , length l and radius r is having its centre of mass at a distance $\frac{l}{4}$ from the centre C and lying on the axis of the cylinder. The cylinder is kept in a liquid of uniform density ρ . The moment of inertia of the rod about the centre of mass is I . The angular acceleration of point A relative to point B just after the rod is released from the horizontal position shown in Figure is

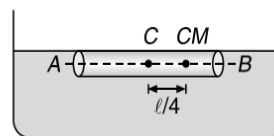

- (A) $\frac{\pi \rho g l^2 r^2}{I}$ (B) $\frac{\pi \rho g l^2 r^2}{4I}$
 (C) $\frac{\pi \rho g l^2 r^2}{2I}$ (D) $\frac{3\pi \rho g l^2 r^2}{4I}$

104. In a given U-tube open at one-end and closed at other end as shown in Figure, the correct relation between P and P_{atm} is (If $d_2 = 2 \times 13.6 \text{ g cm}^{-3}$ and $d_1 = 13.6 \text{ g cm}^{-3}$)

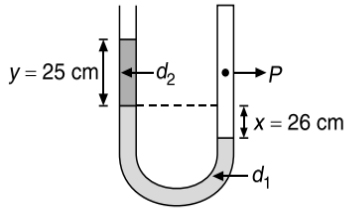

- (A) $P_{\text{atm}} = P$ (B) $P_{\text{atm}} = 2P$
 (C) $P_{\text{atm}} = \frac{P}{2}$ (D) $P_{\text{atm}} = \frac{P}{4}$
105. A substance breaks down by a stress of 10^6 Nm^{-2} . If the density of the material of the wire is $3 \times 10^3 \text{ kg m}^{-3}$, then the length of the wire of that substance which will break under its own weight when suspended vertically is
 (A) 3.4 m (B) 34 m
 (C) 340 m (D) None of these
106. A small block of wood of specific gravity 0.5 is submerged at a depth of 1.2 m in a vessel filled with water. The vessel is accelerated upwards with an acceleration $a_0 = \frac{g}{2}$. Time taken by the block to reach the surface, if it is released with zero initial velocity is ($g = 10 \text{ ms}^{-2}$)
 (A) 0.6 s (B) 0.4 s
 (C) 1.2 s (D) 1 s
107. A body floats in a liquid contained in a beaker. The whole system as shown in Figure falls freely under gravity. The upthrust on the body is

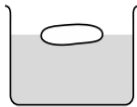

- (A) ZERO
 (B) equal to the weight of liquid displaced
 (C) equal to the weight of the body is air
 (D) equal to the weight of the immersed portion of the body
108. A 5 m long aluminium wire ($Y = 7 \times 10^{10} \text{ Nm}^{-2}$) of diameter 3 mm supports a 40 kg mass. In order to have the same elongation in a copper wire ($Y = 12 \times 10^{10} \text{ Nm}^{-2}$) of the same length under the same weight, the diameter should now be, in mm.
 (A) 1.75 (B) 1.5
 (C) 2.5 (D) 5
109. The pressure of a medium is changed from $1.01 \times 10^5 \text{ Pa}$ to $1.165 \times 10^5 \text{ Pa}$ and change in volume is 10% keeping temperature constant. The Bulk modulus of the medium is
 (A) $204.8 \times 10^5 \text{ Pa}$ (B) $102.4 \times 10^5 \text{ Pa}$
 (C) $51.2 \times 10^5 \text{ Pa}$ (D) $1.55 \times 10^5 \text{ Pa}$

110. A cube of aluminium of sides 0.1 m is subjected to a shearing force of 100 N. The top face of the cube is displaced through 0.02 cm with respect to the bottom face. The shearing strain would be

- (A) 0.02 (B) 0.1
 (C) 0.005 (D) 0.002

111. A horizontal tube of uniform cross-sectional area A is bent in the form of U as shown in Figure. If the liquid of density ρ enters and leaves the tube with velocity v , then the external force F required to hold the bend stationary is

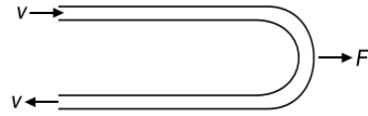

- (A) $F = 0$ (B) ρAv^2
 (C) $2\rho Av^2$ (D) $\frac{1}{2}\rho Av^2$

112. If a bar is made of copper whose coefficient of linear expansion is one and a half times that of iron, the ratio of the force developed in the copper bar to the iron bar of identical lengths and cross-sections, when heated through the same temperature range (Young's modulus for copper may be taken to be equal to that of iron) is

- (A) $\frac{3}{2}$ (B) $\frac{2}{3}$
 (C) $\frac{9}{4}$ (D) $\frac{4}{9}$

113. Two drops of same radius are falling through air with steady speed v . If the two drops coalesce, the terminal speed of bigger drop is

- (A) v (B) $2^{1/3}v$
 (C) $3v$ (D) $4^{1/3}v$

114. A vertical capillary is brought in contact with the water surface (surface tension = T). The radius of the capillary is r and the contact angle $\theta = 0^\circ$. The increase in potential energy of the water (density = ρ) is

- (A) independent of ρ (B) independent of r
 (C) independent of T (D) zero

115. A large open tank has two holes in the wall. One is a square hole of side L at a depth y from the top and the other is a circular hole of radius R at a depth $4y$ from the top. When the tank is completely filled with water, the quantities of water flowing out per second from both holes are the same. Then, R is equal to

- (A) $\frac{L}{\sqrt{2\pi}}$ (B) $2\pi L$
 (C) L (D) $\frac{L}{2\pi}$

116. A rectangular container moves with an acceleration a along the positive direction as shown in Figure. The pressure at the point A in excess of the atmospheric pressure p_0 is (take ρ as the density of liquid)

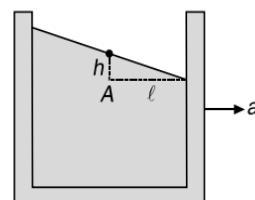

1.142 JEE Advanced Physics: Waves and Thermodynamics

- (A) ρgh (B) ρal
 (C) $\rho(gh + al)$ (D) Both (A) and (B)

117. A uniform rod of length 2.0 m specific gravity 0.5 and mass 2 kg is hinged at one end to the bottom of a tank of water (specific gravity = 1.0) filled upto a height of 1.0 m as shown in Figure. Taking the case $\theta \neq 0^\circ$ the force exerted by the hinge on the rod is ($g = 10 \text{ ms}^{-2}$)

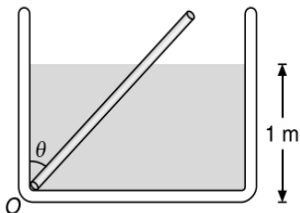

- (A) 10.2 N upwards (B) 4.2 N downwards
 (C) 8.3 N downwards (D) 6.2 N upwards

118. If M is the mass of water that rises in a capillary tube of radius r , then mass of water which will rise in a capillary tube of radius $2r$ is

- (A) $2M$ (B) M
 (C) $4M$ (D) $\frac{M}{2}$

119. A piece of ice is floating in a beaker containing thick sugar solution of water. As the ice melts, the total level of the liquid
 (A) increases (B) decreases
 (C) remains unchanged (D) insufficient data

120. Mercury is poured in a U-tube. Temperature of one side is 50°C and level of mercury on this side is h_1 . Temperature of the other side is 100°C and level of mercury on this side is h_2 . Then

- (A) $h_1 = h_2$ (B) $h_2 < h_1$
 (C) $h_2 > h_1$ (D) $h_2 = 2h_1$

121. An open rectangular tank 1.5 m wide 2 m deep and 2 m long is half filled with water. It is accelerated horizontally at 3.27 ms^{-2} in the direction of its length. The depth of water at rear end of tank if $g = 9.81 \text{ ms}^{-2}$ is

- (A) 0.9 m (B) 1.2 m
 (C) 1.5 m (D) 1.7 m

122. The magnitude of the force developed by raising the temperature from 0°C to 100°C of the iron bar 1.00 m long and 1 cm^2 cross-section when it is held so that it is not permitted to expand or bend is ($\alpha = 10^{-5} \text{ }^\circ\text{C}^{-1}$ and $Y = 10^{11} \text{ Nm}^{-2}$)

- (A) 10^3 N (B) 10^4 N
 (C) 10^5 N (D) 10^9 N

123. A cylindrical vessel contains a liquid of density ρ upto a height h . The liquid is closed by a piston of mass m and area of cross section A . There is a small hole at the bottom of the vessel. The speed v with which the liquid comes out of the hole is

- (A) $\sqrt{2gh}$ (B) $\sqrt{2\left(gh + \frac{mg}{\rho A}\right)}$
 (C) $\sqrt{2\left(gh + \frac{mg}{A}\right)}$ (D) $\sqrt{2gh + \frac{mg}{A}}$

124. The pressure applied from all directions on a cube is P . How much its temperature should be raised to maintain the original volume? The volume elasticity of the cube is β and the coefficient of volume expansion is α

- (A) $\frac{P}{\alpha\beta}$ (B) $\frac{P\alpha}{\beta}$
 (C) $\frac{P\beta}{\alpha}$ (D) $\frac{\alpha\beta}{P}$

125. The extension produced in a wire by the application of a load is 3.0 mm. The extension in a wire of the same material and length but half the radius, by the same load, is

- (A) 0.75 mm (B) 1.5 mm
 (C) 6.0 mm (D) 12.0 mm

126. Two wires of equal length and cross-section are suspended as shown, Their Young's moduli are Y_1 and Y_2 respectively. The equivalent Young's modulus will be

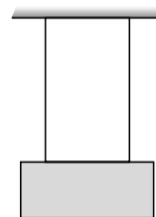

- (A) $Y_1 + Y_2$ (B) $\frac{Y_1 + Y_2}{2}$
 (C) $\frac{Y_1 Y_2}{Y_1 + Y_2}$ (D) $\sqrt{Y_1 Y_2}$

127. A uniform cube of mass M is floating on the surface of a liquid with three fourth of its volume immersed in the liquid of density ρ . The length of the side of the cube is equal to

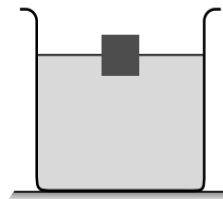

- (A) $\left(\frac{4M}{3\rho}\right)^{\frac{2}{3}}$ (B) $\left(\frac{M}{3\rho}\right)^{\frac{2}{3}}$
 (C) $\left(\frac{M}{4\rho}\right)^{\frac{2}{3}}$ (D) $\left(\frac{4M}{3\rho}\right)^{\frac{1}{3}}$

128. A square gate of size $1 \text{ m} \times 1 \text{ m}$ is hinged at its mid point. A fluid of density ρ fills the space to the left of the gate. The force F required to hold the gate stationary is

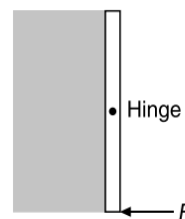

- (A) $\frac{\rho g}{3}$ (B) $\frac{1}{2}\rho g$
 (C) $\frac{\rho g}{6}$ (D) None of these

129. Power required to raise 300 litres of water per minute through a height of 6 m using a pipe of diameter 2.4 cm is ($g = 10 \text{ ms}^{-2}$)
 (A) 600 watt (B) 400 watt
 (C) 1000 watt (D) 2000 watt

130. Young's modulus of rubber is 10^4 Nm^{-2} and area of cross-section is 2 cm^2 . If force of 2×10^5 dynes is applied along its length, then its initial length L becomes
 (A) $3L$ (B) $4L$
 (C) $2L$ (D) L

131. A disk is held against the opening near the bottom of a vessel to keep the liquid, from running out as shown in Figure.

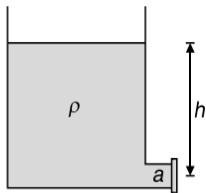

Let the opening be having an area a which is very small compare to the area of the mouth of the vessel. If F_1 be the net force acting on disk by the liquid and air in this case. Now the disk is moved away from the opening through a small distance due to which the liquid comes out of the opening and strikes the disk completely elastically. Let F_2 be the force exerted by the liquid in this condition. Then $\frac{F_1}{F_2}$ is

- (A) $\frac{1}{2}$ (B) 1
 (C) $\frac{2}{1}$ (D) $\frac{1}{4}$

132. A solid sphere of radius R made of material of Bulk modulus K is surrounded by a liquid in a cylindrical container. A massless piston of area A floats on the surface of the liquid when a mass m is placed on the piston to compress the liquid, the fractional change in the radius of the sphere, $\frac{dR}{R}$ is

- (A) $\frac{mg}{4AK}$ (B) $\frac{mg}{3AK}$
 (C) $\frac{mg}{2AK}$ (D) $\frac{mg}{AK}$

133. An area of cross-section of rubber string is 2 cm^2 . Its length is doubled when stretched with a linear force of 2×10^5 dyne. The Young's modulus of the rubber in dyne cm^{-2} will be
 (A) 4×10^5 (B) 1×10^5
 (C) 2×10^5 (D) 1×10^4

134. The diameter of a brass rod is 4 mm and Young's modulus of brass is $9 \times 10^{10} \text{ Nm}^{-2}$. The force required to stretch by 0.1% of its length is

- (A) $360\pi \text{ N}$ (B) 36 N
 (C) $144\pi \times 10^3 \text{ N}$ (D) $36\pi \times 10^5 \text{ N}$

135. The graph shows the extension (Δl) of a wire of length $l \text{ m}$ suspended from the top of a roof at one end and with a load W connected to the other end. If the cross-sectional area of the wire is 10^{-6} m^2 , calculate the Young's modulus of the material of the wire

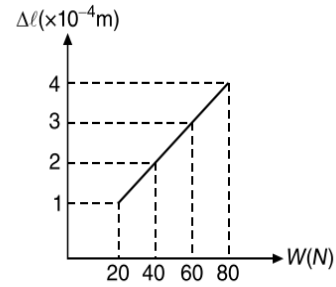

- (A) $2 \times 10^{11} \text{ Nm}^{-2}$ (B) $2 \times 10^{-11} \text{ Nm}^{-2}$
 (C) $3 \times 10^{12} \text{ Nm}^{-2}$ (D) $2 \times 10^{13} \text{ Nm}^{-2}$

136. A uniform rod of length L has a mass per unit length λ and area of cross section A . The elongation in the rod is ℓ due to its own weight if it is suspended from the ceiling of a room. The Young's modulus of the rod is

- (A) $\frac{2\lambda g L^2}{A\ell}$ (B) $\frac{\lambda g L^2}{2A\ell}$
 (C) $\frac{2\lambda g L}{A\ell}$ (D) $\frac{\lambda g \ell^2}{AL}$

137. A drop of water of mass m surface tension T and density ρ is placed between two well cleaned glass plates separated by a distance d . The force of attraction between the plates is

- (A) $\frac{Tm}{2\rho d^2}$ (B) $\frac{4Tm}{\rho d^2}$
 (C) $\frac{2Tm}{\rho d^2}$ (D) $\frac{Tm}{\rho d^2}$

138. The height to which a liquid of surface tension T and density ρ rises between two long parallel plates, a distance d apart is

- (A) $\frac{4T}{\rho g d}$ (B) $\frac{2T}{\rho g d}$
 (C) $\frac{T}{\rho g d}$ (D) $\frac{T}{2\rho g d}$

139. A plate moves normally with the speed v_1 towards a horizontal jet of water of uniform area of cross-section. The jet discharges water at the rate of volume V per second at a speed of v_2 . The density of water is ρ . Assume that water splashes along the surface of the plate at right angles to the original motion. The magnitude of the force acting on the plate due to the jet of water is

1.144 JEE Advanced Physics: Waves and Thermodynamics

- (A) $\rho V v_1$ (B) $\rho \left(\frac{V}{v_2} \right) (v_1 + v_2)^2$
 (C) $\frac{\rho V}{v_1 + v_2} (v_1)^2$ (D) $\rho V (v_1 + v_2)$

140. Water flows into a large tank with flat bottom at the rate of $10^{-4} \text{ m}^3 \text{ s}^{-1}$. Water is also leaking out of a hole of area 1 cm^2 at its bottom. If the height of the water in the tank remains steady, then this height is

- (A) 5.1 cm (B) 1.7 cm
 (C) 2.9 cm (D) 4 cm

141. The ratio of surface tensions of mercury and water is given to be 7.5 while the ratio of their densities is 13.6. Their contact angles, with glass, are close to 135° and 0° , respectively. It is observed that mercury gets depressed by an amount h in a capillary tube of radius r_1 , while water rises by the same amount h in a capillary tube of radius

- r_2 . The ratio, $\left(\frac{r_1}{r_2} \right)$, is then close to
 (A) $\frac{4}{5}$ (B) $\frac{2}{3}$
 (C) $\frac{3}{5}$ (D) $\frac{2}{5}$

142. A closed compartment containing gas is moving with some acceleration in horizontal direction. Neglect effect of gravity. Then the pressure in the compartment is

- (A) same everywhere (B) lower in front side
 (C) lower in rear side (D) lower in upper side

143. When a tap is closed, the manometer attached to the pipe reads $3.5 \times 10^5 \text{ Nm}^{-2}$. When the tap is opened, the reading of manometer falls to $3.0 \times 10^5 \text{ Nm}^{-2}$. The velocity of water in the pipe is

- (A) 0.1 ms^{-1} (B) 1 ms^{-1}
 (C) 5 ms^{-1} (D) 10 ms^{-1}

144. The velocity of the liquid coming out of a small hole of a large vessel containing two different liquids of densities 2ρ and ρ as shown in Figure is

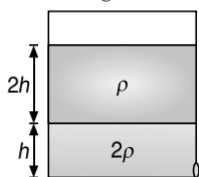

- (A) $\sqrt{6gh}$ (B) $2\sqrt{gh}$
 (C) $2\sqrt{2gh}$ (D) \sqrt{gh}

145. Two ideal liquids are flowing through two different pipes A and B of uniform cross section. When a glass tube is inserted in these pipes, liquids rise in the tube to heights h_1 and $h_2 (< h_1)$ as shown in Figure.

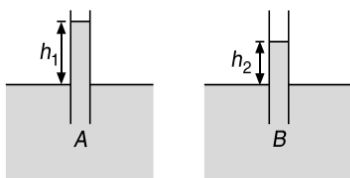

From this we may conclude that

- (A) pressure in A is more than the pressure in B
 (B) pressure in B is more than the pressure in A
 (C) density of liquid in pipe A is less than the density of liquid in pipe B
 (D) None of these

146. A pump draws water from a reservoir and sends it through a horizontal pipe with speed v . The power of the pump is proportional to

- (A) v (B) v^2
 (C) v^3 (D) $v^{3/2}$

147. Water having density ρ is flowing through the uniform horizontal tube of cross-sectional area A with a constant speed v as shown in Figure.

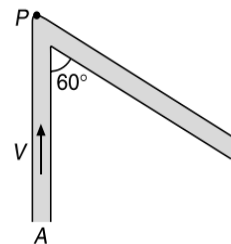

The magnitude of force exerted by the water on the curved corner of the tube (neglect viscous forces) is

- (A) $\sqrt{3}\rho Av^2$ (B) $2\rho Av^2$
 (C) $\sqrt{2}\rho Av^2$ (D) $\frac{\rho Av^2}{\sqrt{2}}$

148. A spherical ball of density ρ and radius 0.003 m is dropped into a tube containing a viscous fluid up to the 0 cm mark as shown in Figure. Viscosity of the fluid is 1.26 Nsm^{-2} and its density ρ_L is $\frac{\rho}{2} = 1260 \text{ kgm}^{-3}$.

Assuming that the ball reaches a terminal speed at 10 cm mark, the time taken by the ball to travel the distance between the 10 cm and 20 cm mark is ($g = 10 \text{ ms}^{-2}$)

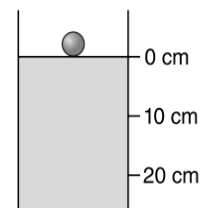

- (A) 2 s (B) 1 s
 (C) 0.5 s (D) 5 s

149. A material has Poisson's ratio 0.50. If a uniform rod of it suffers a longitudinal strain of 2×10^{-3} , then the percentage change in volume is

- (A) 0.6 (B) 0.4
 (C) 0.2 (D) ZERO

150. When at rest, a liquid stands at the same level in both limbs of a U -tube. However a height difference h occurs, when the system is given an acceleration a towards the right as shown in Figure, then h equals

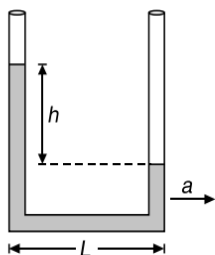

- (A) $\frac{aL}{2g}$ (B) $\frac{gL}{2a}$
 (C) $\frac{gL}{a}$ (D) $\frac{aL}{g}$

151. If a rubber ball is taken down to a 100 m deep lake, its volume decreases by 0.1%. If $g = 10 \text{ ms}^{-2}$ then the Bulk modulus of elasticity for rubber, in Nm^{-2} , is
 (A) 10^8 (B) 10^9
 (C) 10^{11} (D) 10^{10}
152. A wooden block is floating in a liquid with 50% of its volume inside the liquid when the vessel is stationary. Percentage of volume immersed, when the vessel moves upwards with an acceleration $a = \frac{g}{2}$ is
 (A) 75% (B) 25%
 (C) 50% (D) 33.33%
153. A force of 10^3 N stretches the length of a hanging wire by 1 mm. The force required to stretch a wire of same material and length but having four times the diameter by 1 mm is
 (A) $4 \times 10^3 \text{ N}$ (B) $16 \times 10^3 \text{ N}$
 (C) $\frac{1}{4} \times 10^3 \text{ N}$ (D) $\frac{1}{16} \times 10^3 \text{ N}$
154. The height of a mercury barometer is 75 cm at sea level and 50 cm at the top of a hill. Ratio of density of mercury to that of air is 10^4 . The height of the hill is
 (A) 250 m (B) 2.5 km
 (C) 1.25 km (D) 750 km
155. Two rods of different materials having coefficients of linear expansions α_1, α_2 and Young's moduli Y_1, Y_2 respectively are fixed between two rigid massive walls. The rods are heated such that they undergo the same increase in temperature. There is no bending of the rods. If $\alpha_1 : \alpha_2 = 2 : 3$, the thermal stresses developed in the two rods are equal provided $Y_1 : Y_2$ is equal to
 (A) 2 : 3 (B) 1 : 1
 (C) 3 : 2 (D) 4 : 9
156. Two spheres of volume 250 cc each but of relative densities 0.8 and 1.2 are connected by a string and the combination is immersed in a water. The tension in the string is ($g = 10 \text{ ms}^{-2}$)
 (A) 5.0 N (B) 0.5 N
 (C) 1.0 N (D) 2.0 N

157. In the Figure shown, the heavy cylinder (radius R) resting on a smooth surface separates two liquids of densities 2ρ and 3ρ . The height h for the equilibrium of cylinder must be

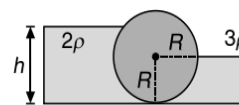

- (A) $\frac{3R}{2}$ (B) $R\sqrt{\frac{3}{2}}$
 (C) $R\sqrt{2}$ (D) $R\sqrt{\frac{2}{3}}$

158. Water from a tap emerges vertically downwards with an initial speed of 1 ms^{-1} . The cross-sectional area of tap is 10^{-4} m^2 . Assume that the pressure is constant throughout and that the flow is steady, the cross-sectional area of stream 0.15 m below the tap is
 (A) $5 \times 10^{-4} \text{ m}^2$ (B) $1 \times 10^{-4} \text{ m}^2$
 (C) $5 \times 10^{-5} \text{ m}^2$ (D) $2 \times 10^{-5} \text{ m}^2$
159. A long cylindrical vessel is half filled with a liquid. When the vessel is rotated about its own vertical axis, the liquid rises up near the wall. If the radius of vessel is 5 cm and its rotational speed is 2 rotations per second, then the difference in the heights between the centre and the sides, in cm, will be
 (A) 1.2 (B) 0.1
 (C) 0.4 (D) 2.0
160. A glass tube 80 cm long and open at both ends is half immersed in mercury. Then the top of the tube is closed and it is taken out of the mercury. A column of mercury 20 cm long then remains in the tube. The atmospheric pressure (in cm of Hg) is
 (A) 75 (B) 30
 (C) 60 (D) 90
 (Assume temperature to be constant)
161. There is a small hole of area a at the bottom of a fixed container having area A containing a liquid upto height h . The top of the liquid as well as the hole at the bottom are exposed to atmosphere. As the liquid comes out of the hole, the
 (A) top surface of the liquid (A) accelerates with acceleration g
 (B) accelerates with acceleration $g \frac{a^2}{A^2}$
 (C) retards with retardation $g \frac{a}{A}$
 (D) retards with retardation $\frac{ga^2}{A^2}$
162. A U-tube having horizontal arm of length 20 cm, has uniform cross-sectional area of 1 cm^2 . It is filled with 60 cc water. The volume of a liquid of density 4 gcc^{-1} that should be poured from one side into the U-tube so that no water is left in the horizontal arm of the tube is

1.146 JEE Advanced Physics: Waves and Thermodynamics

- (A) 60 cc (B) 45 cc
(C) 50 cc (D) 35 cc

- 163.** There are two identical small holes of area of cross-section a on the opposite sides of a tank (lying on a smooth horizontal surface) containing a liquid of density ρ . The difference in height between the holes is h . The horizontal force which will have to be applied to the tank to keep it in equilibrium is

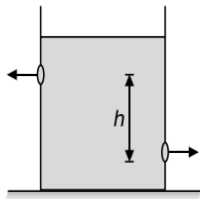

- (A) $gh\rho a$ (B) $\frac{2gh}{\rho a}$
(C) $2\rho agh$ (D) $\frac{\rho gh}{a}$

- 164.** An open tank 10 m long and 2 m deep is filled up to 1.5 m height of oil of specific gravity 0.8. The tank is uniformly accelerated along its length from rest to a speed of 20 ms^{-1} horizontally. The shortest time in which the speed may be attained without spilling any oil is ($g = 10 \text{ ms}^{-2}$)
(A) 20 s (B) 18 s
(C) 10 s (D) 5 s

- 165.** A cubical block of side a and density ρ slides over a fixed inclined plane with constant velocity v . There is a thin film of viscous fluid of thickness t between the plane and the block. Then the coefficient of viscosity of the film will be

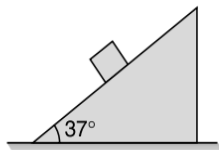

- (A) $\frac{3\rho a g t}{5v}$ (B) $\frac{4\rho a g t}{5v}$
(C) $\frac{\rho a g t}{v}$ (D) $\frac{5\rho a g t}{3v}$

- 166.** One end of a uniform wire of length L and of weight W is attached rigidly to a point in the roof and a weight W_1 is suspended from its lower end. If S is the area of cross-section of the wire, the stress in the wire at a height $\frac{3L}{4}$ from its lower end is

- (A) $\frac{W_1}{S}$ (B) $\frac{W_1 + \frac{W}{4}}{S}$
(C) $\frac{W_1 + \frac{3W}{4}}{S}$ (D) $\frac{W_1 + W}{S}$

- 167.** For silver, Young's modulus is $7.25 \times 10^{10} \text{ Nm}^{-2}$ and Bulk modulus is $11 \times 10^{10} \text{ Nm}^{-2}$. Its Poisson's ratio will be
(A) -1 (B) 0.5
(C) 0.39 (D) 0.25

- 168.** A highly rigid cubical block A of small mass M and side L is fixed rigidly onto another cubical block B of the same dimensions and of low modulus of rigidity η such that the lower face of B is rigidly held on a horizontal surface. A small force F is applied perpendicular to one of the side faces of A . After the force is withdrawn, block A executes small oscillations the time period of which is given by

- (A) $2\pi\sqrt{M\eta L}$ (B) $2\pi\sqrt{\frac{M\eta}{L}}$
(C) $2\pi\sqrt{\frac{ML}{\eta}}$ (D) $2\pi\sqrt{\frac{M}{\eta L}}$

- 169.** Three points A , B and C on a steady flow of a non-viscous and incompressible fluid are observed. The pressure, velocity and height of the points A , B and C are (2, 3, 1), (1, 2, 2) and (4, 1, 2) respectively. If the density of the fluid is 1 kgm^{-3} , $g = 10 \text{ ms}^{-2}$ and all other parameters are given in SI units, then which of the following is correct?
(A) Points A and B lie on the same stream line
(B) Points B and C lie on the same stream line
(C) Points C and A lie on the same stream line
(D) None of these

- 170.** The length of a wire is 1 m and the area of cross-section is $1 \times 10^{-2} \text{ cm}^2$. If the work done for increase in length by 0.2 cm is 0.4 joule, then Young's modulus of the material of the wire is
(A) $2 \times 10^{10} \text{ Nm}^{-2}$ (B) $4 \times 10^{10} \text{ Nm}^{-2}$
(C) $2 \times 10^{11} \text{ Nm}^{-2}$ (D) $4 \times 10^{11} \text{ Nm}^{-2}$

- 171.** Equal volumes of two immiscible liquids of densities ρ and 2ρ are filled in a vessel as shown in Figure. Two small holes are punched at depth $\frac{h}{2}$ and $\frac{3h}{2}$ from the surface of lighter liquid. If v_1 and v_2 are the velocities of efflux at these two holes, then $\frac{v_1}{v_2}$ is
(A) $\frac{1}{2\sqrt{2}}$ (B) $\frac{1}{2}$
(C) $\frac{1}{4}$ (D) $\frac{1}{\sqrt{2}}$

- 172.** One end of a long metallic wire of length L is tied to a ceiling. The other end is tied to a massless spring of spring constant K . A mass M hangs from the free end of the spring. The area of cross-section and the Young's modulus of the wire are A and Y respectively. If the mass is slightly pushed down and released, it will oscillate with a time period T equal to

- (A) $2\pi\sqrt{\frac{M}{K}}$ (B) $2\pi\sqrt{\frac{(YA + KL)M}{YAK}}$
(C) $2\pi\sqrt{\frac{MYA}{KL}}$ (D) $2\pi\sqrt{\frac{ML}{AY}}$

173. A ball floats on the surface of water in a container exposed to the atmosphere. Volume V_1 of its volume is inside the water. If the container is now covered and the air is pumped out. Now let V_2 be the volume immersed in water. Then

- (A) $V_1 = V_2$ (B) $V_1 > V_2$
 (C) $V_2 > V_1$ (D) $V_2 = 0$

174. A soap bubble, blown by a mechanical pump at the mouth of a tube, increases in volume, with time, at a constant rate. The graph that correctly depicts the time dependence of pressure inside the bubble is given by

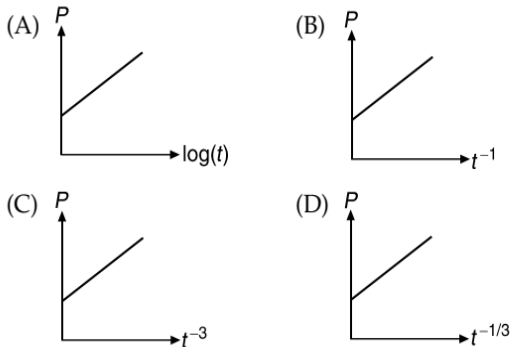

175. For the arrangement shown in Figure, initially the balance A and B reads F_1 and F_2 respectively and $F_1 > F_2$. Finally when the block is immersed in the liquid then the readings of balance A and B are f_1 and f_2 respectively. Identify the statement which is not always (where, F is some force) correct statement.

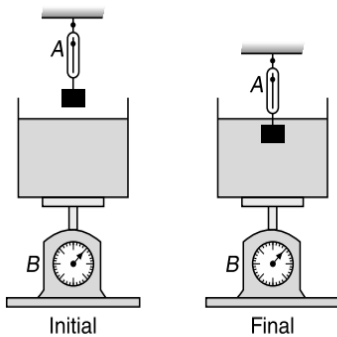

- (A) $f_1 > f_2$ (B) $F_1 + F > F_2 + F$
 (C) $f_1 + f_2 = F_1 + F_2$ (D) None of these

176. A tube 1 cm^2 in cross section is attached to the top of a vessel 1 cm high and cross-section 100 cm^2 . Water fills the system upto a height of 100 cm from the bottom of the vessel. The force exerted by the liquid at the bottom of the vessel is ($g = 10 \text{ ms}^{-2}$)

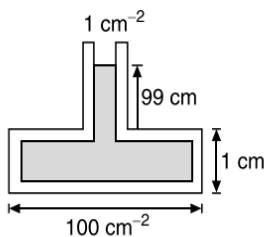

- (A) 1000 N (B) 990 N
 (C) 900 N (D) 100 N

177. The height of water in a vessel is h . The vessel wall of width b is at an angle θ to the vertical. The net force exerted by the water on the wall is

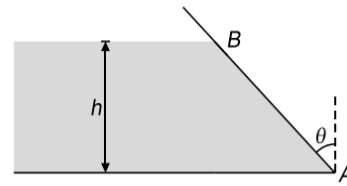

- (A) $\frac{1}{3} \rho b h^2 g \cos \theta$ (B) $\frac{1}{2} b h^2 \rho g$
 (C) $\frac{1}{2} \rho b h^2 g \sec \theta$ (D) ZERO

178. A vessel contains oil (density = 0.8 g cm^{-3}) over mercury (density = 13.6 g cm^{-3}). A uniform sphere floats with half its volume immersed in mercury and the other half in oil. The density of the material of sphere in g cm^{-3} is

- (A) 3.3 (B) 6.4
 (C) 7.2 (D) 12.8

179. In the arrangement shown in Figure $\frac{m_A}{m_B} = \frac{2}{3}$ and the ratio of density of block B and of liquid is 2:1. The system is released from rest. Then

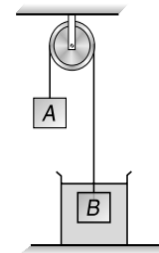

- (A) block B will oscillate but not simple harmonically
 (B) block B will oscillate simple harmonically
 (C) the system will remain in equilibrium
 (D) None of these

180. A circular cylinder of height $h_0 = 10 \text{ cm}$ and radius $r_0 = 2 \text{ cm}$ is opened at the top and filled with liquid. It is rotated about its vertical axis. The speed of rotation if only half the area of the bottom gets exposed is (take $g = 10 \text{ ms}^{-2}$)

- (A) 25 rads^{-1} (B) 50 rads^{-1}
 (C) 100 rads^{-1} (D) 200 rads^{-1}

181. Water flows in a streamline manner through a capillary tube of radius a . The pressure difference being P and the rate of flow is Q . If the radius is reduced to $\frac{a}{2}$ and the pressure is increased to $2P$, then the rate of flow becomes

- (A) $4Q$ (B) $\frac{Q}{2}$
 (C) Q (D) $\frac{Q}{8}$

1.148 JEE Advanced Physics: Waves and Thermodynamics

182. The following four wires are made of the same material. Which of these will have the largest extension when the same tension is applied on all?

- (A) length = 50 cm, diameter = 0.5 mm
 (B) length = 100 cm, diameter = 1 mm
 (C) length = 200 cm, diameter = 2 mm
 (D) length = 300 cm, diameter = 3 mm

183. A body of density ρ is dropped from rest from height h (from the surface of water) into a lake of density of water σ ($\sigma > \rho$). Neglecting all dissipative effects, the acceleration of body while it is in the lake is

- (A) $g\left(\frac{\sigma}{\rho}-1\right)$, upwards (B) $g\left(\frac{\sigma}{\rho}-1\right)$, downwards
 (C) $g\left(\frac{\sigma}{\rho}\right)$, upwards (D) $g\left(\frac{\sigma}{\rho}\right)$, downwards

184. A ball falling in a lake of depth 200 m shows 0.1% decrease in its volume at the bottom. What is the bulk modulus of the material of the ball?

- (A) $19.6 \times 10^8 \text{ Nm}^{-2}$ (B) $19.6 \times 10^{-10} \text{ Nm}^{-2}$
 (C) $19.6 \times 10^{10} \text{ Nm}^{-2}$ (D) $19.6 \times 10^{-8} \text{ Nm}^{-2}$

185. Two rods of different materials having coefficients of thermal expansion α_1, α_2 and Young's moduli Y_1, Y_2 respectively are fixed between two rigid massive walls. The rods are heated such that they undergo the same increase in temperature. There is no bending of the rods. If $\alpha_1 : \alpha_2 = 2 : 3$, the thermal stresses developed in the two rods are equal provided $Y_1 : Y_2$ is equal to

- (A) 2 : 3 (B) 1 : 1
 (C) 3 : 2 (D) 4 : 9

186. An air bubble of radius 1 mm is formed inside water at a depth 10 m below free surface (where air pressure is 10^5 Nm^{-2}). The pressure inside the bubble (if surface tension of water is $7 \times 10^{-2} \text{ Nm}^{-1}$) is

- (A) $2.28 \times 10^{-5} \text{ Nm}^{-2}$ (B) $2.0028 \times 10^5 \text{ Nm}^{-2}$
 (C) $2.14 \times 10^{-5} \text{ Nm}^{-2}$ (D) $2.0014 \times 10^5 \text{ Nm}^{-2}$

187. A piece of gold ($\rho = 19.3 \text{ gcm}^{-3}$) has a cavity in it. It weighs 38.2 g in air and 36.2 g in water. The volume of the cavity in gold is

- (A) 0.2 cm^3 (B) 0.04 cm^3
 (C) 0.02 cm^3 (D) 0.01 cm^3

188. The manometer shown below is used to measure the difference in water level between the two tanks. This difference for the conditions shown in Figure is

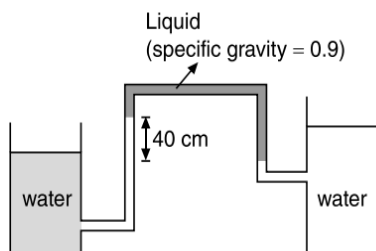

- (A) 2 cm (B) 4 cm
 (C) 6 cm (D) 8 cm

189. A wooden block, with a coin placed on its top, floats in water as shown in Figure. The distance l and h are shown there. After sometime the coin falls into the water. Then

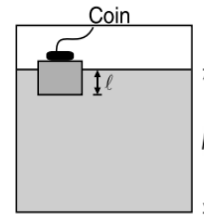

- (A) l decrease and h increases
 (B) l increase and h decreases
 (C) both l and h increase
 (D) both l and h

190. The stress versus strain graphs for wires of two materials A and B are as shown in Figure. If Y_A and Y_B are the Young's moduli of the materials, then

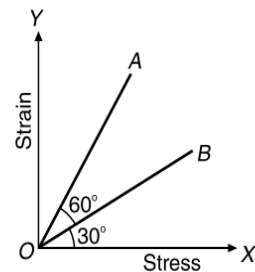

- (A) $Y_B = 2Y_A$ (B) $Y_A = Y_B$
 (C) $Y_B = 3Y_A$ (D) $Y_A = 3Y_B$

191. A cube of side 10 cm is subjected to a tangential force of $5 \times 10^5 \text{ N}$ at the upper face, keeping lower face fixed and the upper face is displaced by 0.001 rad relative to lower face along the direction of tangential force. Then Shear modulus of the material of the cube is

- (A) $5 \times 10^6 \text{ Nm}^{-2}$ (B) $5 \times 10^8 \text{ Nm}^{-2}$
 (C) $5 \times 10^{10} \text{ Nm}^{-2}$ (D) $5 \times 10^{11} \text{ Nm}^{-2}$

192. A tank is filled up to a height $2H$ with a liquid and is placed on a platform of height H from the ground. The distance x from the ground where a small hole is punched to get the maximum range R is

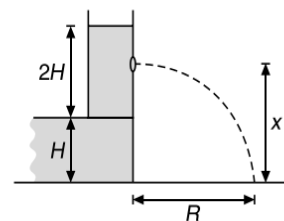

- (A) H (B) $1.25H$
 (C) $1.5H$ (D) $2H$

193. A force F is applied on the wire of radius r and length L and change in the length of wire is l . If the same force F is applied on the wire of the same material and radius $2r$ and length $2L$, Then the change in length of the other wire is

- (A) l (B) $2l$
 (C) $\frac{l}{2}$ (D) $4l$

194. In a cylindrical vessel containing liquid of density ρ , there are two holes in the side walls at heights of h_1 and h_2 respectively such that the range of efflux at the bottom of the vessel is same. The height of a hole for which the range of efflux would be maximum, will be

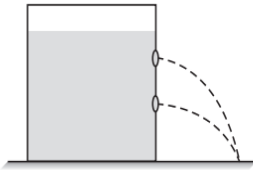

- (A) $h_2 - h_1$ (B) $h_2 + h_1$
 (C) $\frac{h_2 - h_1}{2}$ (D) $\frac{h_2 + h_1}{2}$
195. A cubical block of wood of edge a and density ρ floats in water of density 2ρ . The lower surface of the cube just touches the free end of a massless spring of force constant k fixed at the bottom of the vessel. The weight W put over the block so that it is completely immersed in water without wetting the weight is
- (A) $a(a^2\rho g + k)$ (B) $a(a\rho g + 2k)$
 (C) $a\left(\frac{a\rho g}{2} + 2k\right)$ (D) $a\left(a^2\rho g + \frac{k}{2}\right)$
196. A homogeneous solid cylinder of length $L\left(<\frac{H}{2}\right)$, cross-sectional area $\frac{A}{5}$ is immersed such that it floats with its axis vertical at the liquid interface with length $\frac{L}{4}$ in the denser liquid as shown in Figure. The lower density liquid is open to atmosphere having pressure P_0 . Then, density D of solid is given by

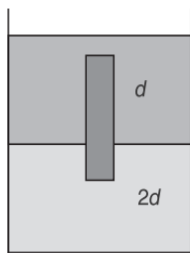

- (A) $\frac{5}{4}d$ (B) $\frac{4}{5}d$
 (C) $4d$ (D) $\frac{d}{5}$
197. A block of ice of total area A and thickness 0.5 m is floating in water. In order to just support a man of mass 100 kg, the area A should be (the specific gravity of ice is 0.9)
- (A) 2.2 m^2 (B) 1.0 m^2
 (C) 0.5 m^2 (D) None of these
198. A block is submerged in a vessel filled with water by a spring attached to the bottom of the vessel. In equilibrium, the spring is compressed. The vessel now moves downwards with an acceleration $a (< g)$. The spring length

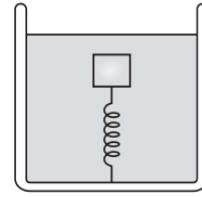

- (A) will become zero
 (B) may increase, decrease or remain constant
 (C) will decrease
 (D) will increase

199. Two boats of base areas A_1 and A_2 , connected by a string are being pulled by an external force F_0 . The viscosity of water is η and depth of the water body is H . When the system attains a constant speed, the tension in the thread will be

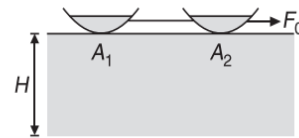

- (A) $F_0\left(\frac{A_1}{A_2}\right)$ (B) $F_0\frac{A_2}{(A_1 + A_2)}$
 (C) $F_0\frac{A_1}{(A_1 + A_2)}$ (D) $F_0\left(\frac{A_2}{A_1}\right)$

200. A block is partially immersed in a liquid and the vessel is accelerating upwards with an acceleration a . The block is observed by two observers O_1 and O_2 , one at rest and the other accelerating with an acceleration a upward. The total buoyant force on the block is

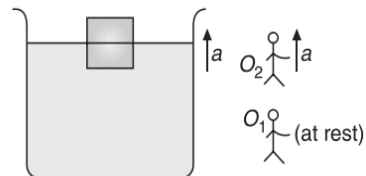

- (A) same for O_1 and O_2
 (B) greater for O_1 than O_2
 (C) greater for O_2 than O_1
 (D) data is not sufficient

201. The normal density of gold is ρ and its Bulk modulus is K . The increase in density of a piece of gold when a pressure P is applied uniformly from all sides is

- (A) $\frac{\rho P}{2K}$ (B) $\frac{\rho K}{2P}$
 (C) $\frac{\rho P}{K - P}$ (D) $\frac{\rho K}{K - P}$

202. At the bottom of a vessel filled with mercury of density ρ surface tension T there is a round hole of radius r . The maximum height of the mercury layer for which the liquid will not flow out through this hole is

- (A) $\frac{T}{r\rho g}$ (B) $\frac{T}{2r\rho g}$
 (C) $\frac{2T}{r\rho g}$ (D) $\frac{4T}{r\rho g}$

1.150 JEE Advanced Physics: Waves and Thermodynamics

203. If the work done in stretching a wire by 1 mm is 2 J, the work necessary for stretching another wire of the same material but double the radius and half the length by 1 mm is
 (A) 16 J (B) 8 J
 (C) 4 J (D) $\frac{1}{4}$ J
204. A given quantity of an ideal gas is at pressure P and absolute temperature T . The isothermal bulk modulus of the gas is
 (A) $\frac{2}{3}P$ (B) P
 (C) $\frac{3}{2}P$ (D) $2P$
205. A solid shell loses half its weight in water. If relative density of shell is 5, the fraction of its volume which happens to be hollow is
 (A) $\frac{3}{5}$ (B) $\frac{2}{5}$
 (C) $\frac{1}{5}$ (D) $\frac{4}{5}$
206. In a U-tube the radii of two columns are respectively r_1 and r_2 . When a liquid of density ρ ($\theta = 0^\circ$) is filled in it, a level difference of h is observed on two arms, then the surface tension of the liquid is
 (A) $\frac{\rho g h r_1 r_2}{2(r_2 - r_1)}$ (B) $h \rho g (r_2 - r_1)$
 (C) $\frac{h \rho g (r_2 - r_1)}{2}$ (D) $\frac{h \rho g}{2(r_2 - r_1)}$
207. A copper piece of mass 10 g is suspended by a vertical spring. The spring elongates 1 cm over its natural length to keep the piece in equilibrium. A beaker containing water is now placed below the piece so as to immerse the piece completely in water. If density of copper is 9000 kgm^{-3} and $g = 10 \text{ ms}^{-2}$, then the approximate elongation of the spring is
 (A) 0.45 cm (B) 0.89 cm
 (C) 1.02 cm (D) 1.86 cm
208. A U-tube is partially filled with water. Oil which does not mix with water is next poured into one side, until water rises by 25 cm on the other side. If the density of oil is 0.8 gcm^{-3} , the oil level will stand higher than the water level by
 (A) 6.25 cm (B) 12.50 cm
 (C) 31.75 cm (D) 25 cm
209. The compressibility of water is 5×10^{-5} per unit atmospheric pressure. The decrease in volume of 100 cm^3 of water under a pressure of 100 atmosphere will be
 (A) 0.5 cm^3 (B) $5 \times 10^{-5} \text{ cm}^3$
 (C) 0.025 cm^3 (D) 0.005 cm^3
210. There is a hole of radius r at the bottom of a long cylindrical vessel of glass. The depth to which the vessel can be lowered vertically in a deep water bath (surface tension is T and density is ρ) without any water entering inside is
 (A) $\frac{4T}{\rho r g}$ (B) $\frac{3T}{\rho r g}$
 (C) $\frac{2T}{\rho r g}$ (D) $\frac{T}{\rho r g}$
211. A rubber cord 10 m long is suspended vertically. How much does it stretch under its own weight (Density of rubber is 1500 kgm^{-3} , $Y = 5 \times 10^8 \text{ Nm}^{-2}$, $g = 10 \text{ ms}^{-2}$)
 (A) $15 \times 10^{-4} \text{ m}$ (B) $7.5 \times 10^{-4} \text{ m}$
 (C) $12 \times 10^{-4} \text{ m}$ (D) $25 \times 10^{-4} \text{ m}$
212. A wooden cube just floats inside water when a 200 g mass is placed on it. When the mass is removed, the cube is 2 cm above the water level. What is the size of each sides of the cube?
 (A) 6 cm (B) 8 cm
 (C) 10 cm (D) 12 cm
213. A solid ball of density ρ_1 and radius r falls vertically through a liquid of density ρ_2 . Assume that the viscous force acting on the ball is $F = krv$, where k is a constant and v its velocity. The terminal velocity of the ball is
 (A) $\frac{4\pi g r^2 (\rho_1 - \rho_2)}{3k}$ (B) $\frac{2\pi r (\rho_1 - \rho_2)}{3gk}$
 (C) $\frac{2\pi g (\rho_1 + \rho_2)}{3g r^2 k}$ (D) None of these
214. A vessel contains oil of density 0.8 gcm^{-3} over mercury of density 13.6 gcm^{-3} . A homogeneous sphere floats with half its volume immersed in mercury and the other half in oil. The density of the material of the sphere in gcm^{-3} is
 (A) 3.3 (B) 6.4
 (C) 1.05 (D) 1.0
215. A steel wire having a radius of 2.0 mm, carrying a load of 4 kg, is hanging from a ceiling. Given that $g = 3.1\pi \text{ ms}^{-2}$, what will be the tensile stress that would be developed in the wire?
 (A) $4.8 \times 10^6 \text{ Nm}^{-2}$ (B) $3.1 \times 10^6 \text{ Nm}^{-2}$
 (C) $5.2 \times 10^6 \text{ Nm}^{-2}$ (D) $6.2 \times 10^6 \text{ Nm}^{-2}$
216. Water rises to a height of 10 cm in a certain capillary tube. When another identical tube is dipped in mercury, the level of mercury is depressed by 3.42 cm. If the density of mercury is 13.6 gcc^{-1} , the angle of contact for water in contact with glass is 0° and mercury in contact with glass is 135° , then the ratio of surface tension of water to that of Hg is
 (A) 1:3 (B) 1:4
 (C) 1:5.5 (D) 1:6.5
217. What is the radius of a steel sphere that will float on water with exactly half the sphere submerged? Density of steel is $7.9 \times 10^3 \text{ kgm}^{-3}$ and surface tension of water is $7 \times 10^{-2} \text{ N}$
 (A) 2.6 cm (B) 4.6 mm
 (C) 1.2 mm (D) 6.5 mm
218. A fixed container of height H with large cross-sectional area A is completely filled with water. Two small orifice of cross-sectional area a are made, one at the bottom and

the other on the vertical side of the container at a distance $\frac{H}{2}$ from the top of the container. The time taken by the water level to reach a height of $\frac{H}{2}$ from the bottom of the container is

- (A) $\frac{2A}{3a} \sqrt{\frac{2H}{g}}$ (B) $\frac{2A}{3a} (\sqrt{2}-1) \sqrt{\frac{H}{g}}$
 (C) $\frac{3A}{2a} (\sqrt{2}-1) \sqrt{\frac{H}{g}}$ (D) $\frac{3A}{2a} \sqrt{\frac{2H}{g}}$

219. A capillary tube is dipped in water to a depth and the water rises to a height $h (< l)$ in the capillary tube. The lower end of the tube is closed in water by putting a thumb over it. The tube is now taken out and the thumb is removed from the lower end and it is kept open. The length of liquid column in the tube will be

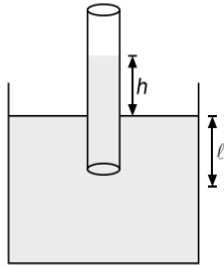

- (A) l (B) $l+h$
 (C) h (D) $2h$

220. A steel wire of length 20 cm and uniform cross-section 1 mm^2 is tied rigidly at both the ends. The temperature of the wire is altered from 40°C to 20°C . What is the magnitude of force developed in the wire? (Coefficient of linear expansion for steel, $\alpha = 1.1 \times 10^{-5} \text{ }^\circ\text{C}^{-1}$ and Y for steel is $2.0 \times 10^{11} \text{ Nm}^{-2}$)
 (A) $2.2 \times 10^6 \text{ N}$ (B) 16 N
 (C) 8 N (D) 44 N

221. There is a horizontal film of soap solution. On it a thread is placed in the form of a loop. The film is punctured inside the loop and the thread becomes a circular loop of radius R . If the surface tension of the soap solution be T , then the tension in the thread will be
 (A) $\frac{\pi R^2}{T}$ (B) $\pi^2 R^2 T$
 (C) $2\pi RT$ (D) $2RT$

222. When too many water drops coalesce to form a bigger drop
 (A) energy is absorbed
 (B) energy is liberated
 (C) energy is neither liberated nor absorbed
 (D) energy may either be liberated or be absorbed depending on the nature of liquid

223. A U -tube of uniform cross-section is partially filled with a liquid 1. Another liquid 2 which does not mix with liquid 1 is poured into one side. It is found that the liquid levels of the two sides of the tube are the same, while the level of

liquid 1 has risen by 2 cm. If the specific gravity of liquid 1 is 1.1, the specific gravity of liquid 2 must be

- (A) 1.12 (B) 1.1
 (C) 1.05 (D) 1.0

224. In an experiment, brass and steel wires of length 1 m each with areas of cross section 1 mm^2 are used. The wires are connected in series and one end of the combined wire is connected to a rigid support and other end is subjected to elongation. The stress required to produce a net elongation of 0.2 mm is, [Given, the Young's Modulus for steel and brass are, respectively, $120 \times 10^9 \text{ Nm}^{-2}$ and $60 \times 10^9 \text{ Nm}^{-2}$]

- (A) $8 \times 10^6 \text{ Nm}^{-2}$ (B) $1.2 \times 10^6 \text{ Nm}^{-2}$
 (C) $4.0 \times 10^6 \text{ Nm}^{-2}$ (D) $0.2 \times 10^6 \text{ Nm}^{-2}$

225. A capillary tube of radius R is immersed in water and water rises in it to a height h . Mass of water in capillary tube is M . If the radius of the tube is doubled, mass of water that will rise in the capillary tube will be

- (A) $2M$ (B) M
 (C) $\frac{M}{2}$ (D) $4M$

226. A capillary is dipped in water vessel kept on a freely falling lift, then

- (A) water will not rise in the tube
 (B) water will rise to the maximum available height of the tube
 (C) water will rise to the height observed under normal condition
 (D) water will rise to the height below that observed under normal condition

227. A thin metal disc of radius r floats on a liquid surface and bends the surface downwards along the perimeter making an angle θ with vertical edge of the disc. If the disc displaces a weight of liquid w and surface tension of liquid is T , then the weight of metal disc is

- (A) $2\pi rT + w$ (B) $2\pi rT \cos\theta - w$
 (C) $2\pi rT \cos\theta + w$ (D) $w - 2\pi rT \cos\theta$

228. A spherical steel ball released at the top of a long column of glycerine of length l , falls through a distance $\frac{l}{2}$ with accelerated motion and the remaining distance $\frac{l}{2}$ with uniform velocity. Let t_1 and t_2 denote the times taken to cover the first and second half and W_1 and W_2 the work done against gravity in the two halves, then

- (A) $t_1 < t_2, W_1 > W_2$ (B) $t_1 > t_2, W_1 < W_2$
 (C) $t_1 = t_2, W_1 = W_2$ (D) $t_1 > t_2, W_1 = W_2$

229. The radii of the two columns in U -tube are r_1 and $r_2 (> r_1)$. When a liquid of density ρ (angle of contact is 0°) is filled in it, the level difference of liquid in two arms is h . The surface tension of liquid is

- (A) $\frac{\rho gh r_1 r_2}{2(r_2 - r_1)}$ (B) $\frac{\rho gh (r_2 - r_1)}{2r_1 r_2}$
 (C) $\frac{2(r_2 - r_1)}{\rho gh r_1 r_2}$ (D) $\frac{\rho gh}{2(r_2 - r_1)}$

1.152 JEE Advanced Physics: Waves and Thermodynamics

230. A fixed volume of iron is drawn into a wire of length L . The extension x produced in this wire by a constant force F is proportional to
- (A) $\frac{1}{L^2}$ (B) $\frac{1}{L}$
(C) L^2 (D) L
231. A piece of steel has a weight w in air, w_1 when completely immersed in water and w_2 when completely immersed in an unknown liquid. The relative density (specific gravity) of liquid is
- (A) $\frac{w - w_1}{w - w_2}$ (B) $\frac{w - w_2}{w - w_1}$
(C) $\frac{w_1 - w_2}{w - w_1}$ (D) $\frac{w_1 - w_2}{w - w_2}$
232. A metal ball immersed in alcohol weight W_1 at 0°C and W_2 at 50°C . The coefficient of cubical expansion of the metal is less than that of the alcohol. Assuming that the density of the metal is large compared to that of alcohol, it can be shown that
- (A) $W_1 > W_2$ (B) $W_1 = W_2$
(C) $W_1 < W_2$ (D) All of the above
233. At 40°C , a brass wire of 1 mm radius is hung from the ceiling. A small mass, M is hung from the free end of the wire. When the wire is cooled down from 40°C to 20°C it regains its original length of 0.2 m. The value of M is close to (Coefficient of linear expansion and Young's modulus of brass are $10^{-5}^\circ\text{C}^{-1}$ and 10^{11}Nm^{-2} , respectively; $g = 10\text{ms}^{-2}$)
- (A) 0.5 kg (B) 0.9 kg
(C) 6.28 kg (D) 9 kg
234. A and B are two soap bubbles. Bubble A is larger than B . If these are now joined by a tube then
- (A) the bubble A becomes more large
(B) the bubble B becomes more large
(C) both the bubbles acquire the same size
(D) both the bubbles will get bursted
235. The volume of a liquid flowing per second out of an orifice at the bottom of a tank does not depend upon
- (A) the height of the liquid above the orifice
(B) the acceleration due to gravity
(C) the density of the liquid
(D) the area of the orifice
236. Two parallel glass plates are dipped partly in the liquid of density ρ keeping them vertical. If the distance between the plates is x , Surface tension for liquid is T and angle of contact is θ then rise of liquid between the plates due to capillary will be
- (A) $\frac{T \cos \theta}{x\rho}$ (B) $\frac{2T \cos \theta}{x\rho g}$
(C) $\frac{2T}{x\rho g \cos \theta}$ (D) $\frac{T \cos \theta}{x\rho g}$
237. Water flows in a horizontal tube shown in Figure. The pressure of water changes by 600Nm^{-2} between A and B where the areas of cross-section are 30cm^2 and 15cm^2 respectively. The rate of flow of water through the tube is

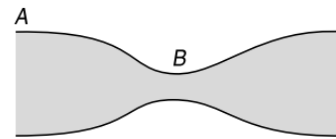

- (A) $600\text{cm}^3\text{s}^{-1}$ (B) $1200\text{cm}^3\text{s}^{-1}$
(C) $1800\text{cm}^3\text{s}^{-1}$ (D) $2400\text{cm}^3\text{s}^{-1}$

MULTIPLE CORRECT CHOICE TYPE QUESTIONS

This section contains Multiple Correct Choice Type Questions. Each question has four choices (A), (B), (C) and (D), out of which ONE OR MORE is/are correct.

- A large wooden plate of area 10m^2 floating on the surface of a river is made to move horizontally with a speed of 2ms^{-1} by applying a tangential force. If river is 1 m deep, coefficient of viscosity of water is 10^{-3}Nsm^{-2} and the water in contact with the bed, then select the correct statement(s).

(A) The speed gradient is 2s^{-1}
(B) The speed gradient is 1s^{-1}
(C) The force required to keep the plate moving with constant speed is 0.02 N
(D) The force required to keep the plate moving with constant speed is 0.01 N
- A sample of metal weighs 210 g in air, 180 g in water and 120 g in liquid. Then relative density (RD) of

(A) metal is 3 (B) metal is 7
(C) liquid is 3 (D) liquid is $\frac{1}{3}$
- An ideal liquid is flowing in streamline motion through a tube with its axis horizontal. Consider two points A and B in the tube at the same horizontal level, then select the correct statement(s).

(A) The pressure at A and B are equal for any shape of the tube.
(B) The pressures are equal if the tube has a uniform cross-section.
(C) The pressure can never be equal.
(D) The pressure may be equal even if the tube has a non-uniform cross-section.
- A light rod of length 2 m is suspended from a ceiling horizontally by means of two vertical wires of equal length tied to its ends. One of the wires is made of steel and is of cross-section 10^{-3}m^2 and the other is of brass of cross-section $2 \times 10^{-3}\text{m}^2$. If x is the distance from steel wire end, at which a weight may be hung, $Y_{\text{steel}} = 2 \times 10^{11}\text{Pa}$ and $Y_{\text{brass}} = 10^{11}\text{Pa}$, then which of the following statement(s) is/are correct?

(A) $x = 1\text{m}$
(B) $x = 2\text{m}$
(C) $x = 0.5\text{m}$
(D) $x = 0.75\text{m}$

- (A) $x = 1.33$ m, if stress is equal in both wires.
 (B) $x = 1.42$ m, if stress is equal in both wires.
 (C) $x = 1$ m, if strain is equal in both wires.
 (D) $x = 1.2$ m, if strain is equal in both wires.
5. A ball of density ρ is dropped on a horizontal solid surface. It bounces elastically from the surface and returns to its original position in time t_1 . Another identical ball is released from the same height, but this time it strikes the surface of a liquid of density ρ_L and takes time t_2 to return to its original height. If $\rho < \rho_L < 2\rho$, then select the correct statement(s).
 (A) $t_2 < t_1$
 (B) $t_2 > t_1$
 (C) If $\rho = \rho_L$, then the speed of the ball inside the liquid will be independent of its depth.
 (D) The motion of the ball is not simple harmonic.
6. A non-viscous incompressible liquid is flowing through a horizontal pipe of variable cross section as shown in Figure. Select the correct option(s).

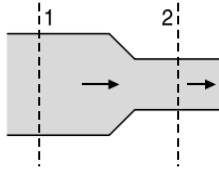

- (A) The speed of liquid at section-2 is more.
 (B) The volume of liquid flowing per second from section-2 is more.
 (C) The mass of liquid flowing per second at both the sections is same.
 (D) The pressure at section-2 is less.
7. For two different materials it is given that $Y_1 > Y_2$ and $B_1 < B_2$. Here, Y is Young's modulus of elasticity and B , the Bulk modulus of elasticity. Then can conclude that
 (A) 1 is more ductile (B) 2 is more ductile
 (C) 1 is more malleable (D) 2 is more malleable
8. Two wires A and B have equal lengths and are made of the same material, but diameter of wire A is twice that of wire B . Then, for a given load attached to the wires, select the correct statement(s).
 (A) Extension is same in both the wires.
 (B) Extension in B will be four times that in A .
 (C) Strain is equal in both the wires.
 (D) Strain in B is four times that in A .
9. A siphon is a device used to transfer liquid from a higher level to a lower level. For the siphon to work, the condition of working is

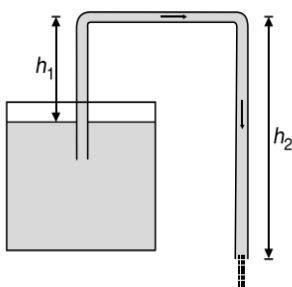

- (A) $h_2 > h_1$
 (B) $h_1 = 2h_2$
 (C) h_1 should be greater than the height of corresponding liquid barometer.
 (D) h_1 should be less than the height of corresponding liquid barometer.

10. An ideal liquid flows through a horizontal tube. The velocities of the liquid in the two sections, which have areas of cross-section A_1 and A_2 , are v_1 and v_2 respectively. The difference in the levels of the liquid in the two vertical tubes is h

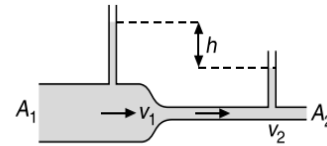

- (A) The volume of the liquid flowing through the tube in unit time is $A_1 v_1$
 (B) $v_2^2 - v_1^2 = 2gh$
 (C) $v_2 - v_1 = \sqrt{2gh}$
 (D) The energy per unit mass of the liquid is the same in both sections of the tube

11. A tank open at the top contains a liquid up to a height H as shown in Figure.

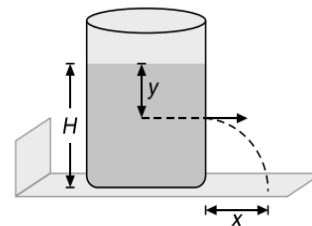

A small orifice is made in the wall of the tank at a distance y below the free surface of the liquid in the tank and the liquid emerging from the orifice hits the ground at a distance x from the tank. Select the correct statement(s).

- (A) The maximum value of x will depend on the density of the liquid
 (B) x is maximum for $y = \frac{H}{2}$
 (C) The maximum value of x is H
 (D) If y is increased from zero to H , x first increases and then decreases.

12. The graph of elastic potential energy (U) stored versus extension, for a steel wire of volume 200 cc having $Y_S = 2 \times 10^{11}$ Pa is shown in Figure. If A is the area of cross-section of the wire and its original length is L , then

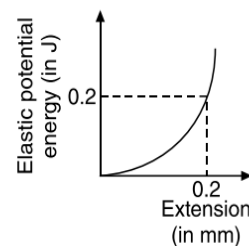

1.154 JEE Advanced Physics: Waves and Thermodynamics

- (A) $A = 10^{-3} \text{ m}^2$ (B) $A = 10^{-4} \text{ m}^2$
 (C) $L = 2 \text{ m}$ (D) $L = 1.5 \text{ m}$

13. Three different liquids of densities ρ_1 , ρ_2 and ρ_3 are filled in a U-tube as shown in Figure.

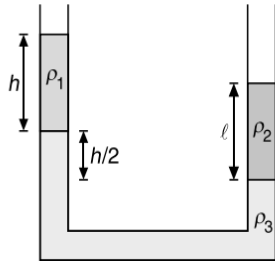

Select the correct conclusion(s) you infer from the Figure.

- (A) $\rho_1 > \rho_2$ (B) $\rho_2 > \rho_1$
 (C) $\rho_2 = 2\rho_3 - \rho_1$ (D) $\rho_3 = 2(\rho_2 - \rho_1)$

14. A solid sphere, a cone and a cylinder all having same mass, density and radius are floating in water. Let f_1 , f_2 and f_3 be the respective fraction of their volumes inside the water and h_1 , h_2 and h_3 be their respective depths inside water, then

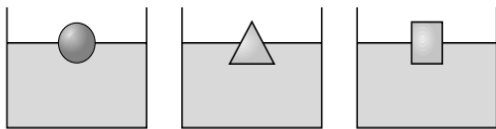

- (A) $f_3 > f_2 > f_1$
 (B) $f_1 = f_2 = f_3$
 (C) $h_3 < h_1$
 (D) $h_3 < h_2$

15. A body of mass m is attached to the lower end of a metal wire, whose upper end is fixed. If elongation in the wire is l , then select the correct statement(s).

- (A) Elastic potential energy stored in wire is mgl .
 (B) Loss in gravitational potential energy of mass is mgl .
 (C) Elastic potential energy stored in wire is $\frac{mgl}{2}$.
 (D) Heat produced is $\frac{mgl}{2}$.

16. A liquid of density ρ comes out with a velocity v from a horizontal tube of area of cross-section A . The reaction force exerted by the liquid on the tube is F . Then, we have

- (A) $F \propto \rho$ (B) $F \propto v^2$
 (C) $F \propto A$ (D) $F \propto v$

17. Equal volumes of a liquid are poured in the three vessels A, B, and C. All the vessels have same base area. Select the correct statement(s).



- (A) Force on base of vessel A is maximum.
 (B) Force on base of vessel C is maximum.
 (C) Net force exerted by liquid in all the three vessels is equal.
 (D) Net force exerted by liquid in vessel A is maximum

18. Which of the following option(s) is correct?

- (A) Viscosity of liquids increases with temperature
 (B) Viscosity of gases increases with temperature
 (C) Surface tension of liquids decreases with temperature
 (D) For angle of contact $\theta = 0^\circ$, liquid neither rises nor falls on capillary

19. Select the correct alternative(s)

- (A) elastic forces are always conservative
 (B) elastic forces are not always conservative
 (C) elastic forces are conservative only when Hooke's law is obeyed
 (D) elastic forces may be conservative even when Hooke's law is not obeyed

20. A steel rod of cross-sectional area 16 cm^2 and two brass rods each of cross-sectional area 10 cm^2 together support a load of 5000 kg as shown in Figure.

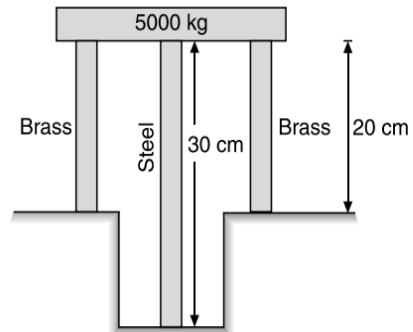

If $Y_{\text{steel}} = 2 \times 10^6 \text{ kgcm}^{-2}$ and $Y_{\text{brass}} = 10^6 \text{ kgcm}^{-2}$, then select the correct option(s).

- (A) Stress in brass rod is 141 kgfcm^{-2}
 (B) Stress in steel rod is 141 kgfcm^{-2}
 (C) Stress in brass rod is 121 kgfcm^{-2}
 (D) Stress in steel rod is 161 kgfcm^{-2}

21. A load W is suspended from a wire of length L and area of cross-section A . If change in length of the wire is say ΔL , then ΔL can be made twice if

- (A) W is made two times
 (B) L is made two times
 (C) A is made half
 (D) A is made two times

22. The cross-sectional area of the mouth of vessel is A_1 and that of its base is A_2 as shown in Figure.

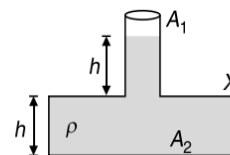

A liquid of density ρ fills both the sections, each up to a height h . Neglecting atmospheric pressure, select the correct statement(s).

- (A) The pressure at the base of the vessel is $2h\rho g$
 (B) The force exerted by the liquid on the base of the vessel is $2h\rho g A_2$

- (C) The weight of the liquid is $< 2h\rho gA_2$
- (D) The walls of the vessel at the level X exert a downward force $h\rho g(A_2 - A_1)$ on the liquid

23. Two wires A and B of same length are made of same material. The load F versus extension Δx graph for the two wires is shown in Figure. Select the correct statement(s).

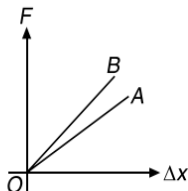

- (A) Area of cross section of A is greater than B .
 - (B) Wire B is more elastic than A .
 - (C) Area of cross section of B is greater than A .
 - (D) Wire A is more elastic than B .
24. The viscous force acting on a solid ball of surface area A , volume V moving with terminal velocity v is proportional to
- (A) A
 - (B) $A^{1/2}$
 - (C) $V^{1/3}$
 - (D) v
25. A spring balance A reads 2 kg with a block of mass m suspended from it and another balance B reads 5 kg when a beaker with liquid is put on the pan of the balance. The two balances are now so arranged that the hanging block is inside the liquid in the beaker as shown in Figure. Then the balance

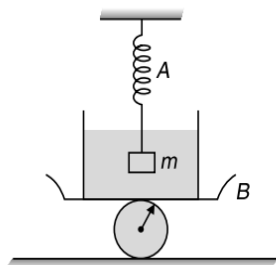

- (A) A reads more than 2 kg
 - (B) B reads more than 5 kg
 - (C) A reads less than 2 kg
 - (D) A reads 2 kg and B reads 5 kg
26. An iron casting weighs 27 kg in air and 18 kg in water. If density of iron is 7800 kgm^{-3} , then select the correct option(s).
- (A) Outer volume of casting is 9000 cm^3
 - (B) Outer volume of casting is 6000 cm^3
 - (C) Volume of cavity inside the casting is 5538 cm^3
 - (D) Volume of cavity inside the casting is 780 cm^3

27. A block of weight W is floating in a liquid as shown in Figure. Let P be the pressure at bottom of block and U be the upthrust due to liquid acting on the block. If the container starts moving upwards with some positive acceleration, then let the new respective values of weight, pressure and upthrust be W' , P' and U' , then

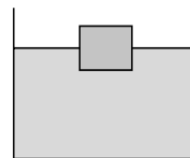

- (A) $W' > W$
- (B) $P' > P$
- (C) $U' > U$
- (D) $F' = W'$

28. Two large identical beakers 1 and 2 each are filled with identical liquids to a same height $5h$. Each beaker has a small orifice in its wall, one h below the free surface of liquid and the other h above the horizontal surface on which the beakers are kept. If v_1 and v_2 be the respective speeds of liquid coming out of orifice, t_1 and t_2 be the respective times taken by the liquid to hit the ground, R_1 and R_2 be the respective ranges of the liquid where it hits the horizontal surface, then

- (A) $\frac{v_1}{v_2} = \frac{1}{2}$
- (B) $\frac{v_1}{v_2} = \frac{1}{4}$
- (C) $\frac{t_1}{t_2} = 2$
- (D) $\frac{R_1}{R_2} = 1$

29. A massless conical flask filled with a liquid is kept on a horizontal surface and the arrangement is kept in vacuum. If the force exerted by the liquid on the base of the flask is W_1 and the force exerted by the flask on the table is W_2 , then

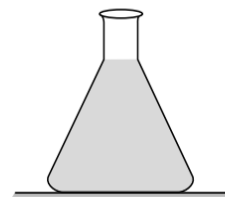

- (A) $W_1 = W_2$
- (B) $W_1 > W_2$
- (C) $W_1 < W_2$
- (D) The force exerted by the liquid on the walls of the flask is $(W_1 - W_2)$

30. Two light wires P and Q are made of same material, have radii r_p and r_Q , respectively have a block of mass m attached between them as shown in Figure.

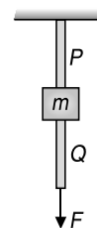

- When a force $F = \frac{mg}{3}$ is applied on the lower end of the wire Q , then one of the wires breaks. Select the correct statement(s).
- (A) When $r_p = r_Q$, then P breaks.
 - (B) When $r_p < 2r_Q$, then P breaks.
 - (C) When $r_p = 2r_Q$, then either P or Q may break.
 - (D) The lengths of P and Q must be known in order to predict which wire will break.

1.156 JEE Advanced Physics: Waves and Thermodynamics

31. In a block of ice floating in water of density ρ_w in a beaker some pieces of impurity of density ρ are embedded. When the ice melts, the level of water in the beaker will

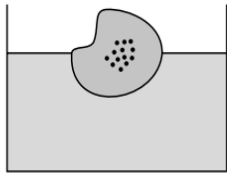

- (A) rise if $\rho > \rho_w$
 (B) fall if $\rho < \rho_w$
 (C) fall if $\rho > \rho_w$
 (D) remain unchanged, if $\rho < \rho_w$
32. A ball of density ρ is dropped from some height on the surface of a non-viscous liquid of density 2ρ . Select the correct statement(s).

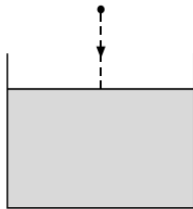

- (A) Motion of ball is periodic but not simple harmonic
 (B) Acceleration of ball in air and in liquid are equal
 (C) Magnitude of upthrust in the liquid is two times the weight of ball
 (D) Net force on ball in air and in liquid are equal and opposite
33. A metal wire of length L , area of cross-section A and Young's modulus Y is stretched by a variable force F such that F is always slightly greater than the elastic forces of resistance in the wire. When the elongation in the wire is l , then the
- (A) work done by F is $\frac{YAl^2}{2L}$
 (B) work done by F is $\frac{YAl^2}{L}$
 (C) elastic potential energy stored in wire is $\frac{YAl^2}{2L}$
 (D) elastic potential energy stored in wire is $\frac{YAl^2}{4L}$

34. A tank is filled up to a height h with a liquid and is placed on a platform of height h from the ground. To get maximum range x_m , a small hole is punched at a distance of y from the free surface of the liquid. Then

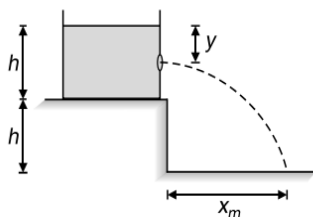

- (A) $x_m = 2h$ (B) $x_m = 1.5h$
 (C) $y = h$ (D) $y = 0.75h$

35. A vessel of very large height filled with an ideal liquid has two small circular holes 1 and 2 made at depths h and $16h$ below the free surface of the liquid respectively. If radius of hole 1 is twice that of hole 2, then select the correct alternative(s).



- (A) Initially more volume of liquid will flow from hole-2 per unit time
 (B) Initially equal volumes of liquid will flow from both the holes in unit time
 (C) After some time more volume of liquid will flow from hole-1 per unit time
 (D) After some time more volume of liquid will flow from hole-2 per unit time
36. Water in a tank is filled to a height H . The tank has two holes 1 and 2. The hole 1 and 2 are at the respective depth H and $H/4$ below the free surface of water. The area of hole 2 is twice that of area of hole 1. If v be the speed of efflux of liquid coming out from the hole and Q is the rate of flow of liquid, then

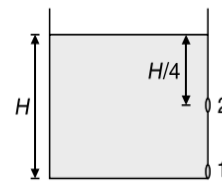

- (A) $v_1 = 4v_2$ (B) $v_1 = 2v_2$
 (C) $Q_1 = Q_2$ (D) $Q_1 = 2Q_2$
37. A piece of ice is floating in a liquid kept in a beaker. The level of liquid in the beaker
- (A) remains same if liquid is water.
 (B) falls if liquid is water.
 (C) rises if liquid is denser than water.
 (D) falls if liquid is lighter than water.
38. Four points A, B, C and D are taken inside an incompressible liquid that completely fills a closed container accelerating toward the right as shown in Figure. If P be the pressure at a point inside the liquid, then select the correct option(s).

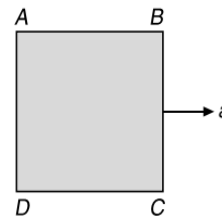

- (A) $P_C > P_A$ (B) $P_A > P_B$
 (C) $P_A > P_C$ (D) $P_D > P_B$
39. Water is being poured in a vessel at a constant rate $\alpha \text{ m}^3\text{s}^{-1}$. There is a small hole of area a at the bottom of the tank. The maximum level of water in the vessel is proportional to
- (A) α (B) α^2
 (C) a^{-2} (D) a^{-1}

40. In the figure, an ideal liquid flows through the tube, which is of uniform cross-section. The liquid has velocities v_A , v_B and pressures P_A , P_B at points A and B respectively

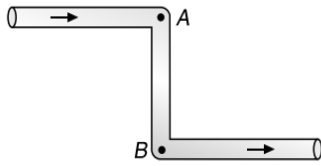

- (A) $v_B > v_A$ (B) $v_A = v_B$
 (C) $P_B > P_A$ (D) $P_A = P_B$
41. A vessel is filled with mercury to a height of 0.9 m. If the barometric height is 0.7 m mercury, then select the correct statement(s).
- (A) The vessel can be completely emptied with the aid of a siphon
 (B) The vessel cannot be emptied completely with the aid of a siphon
 (C) The vessel can be emptied with at least 0.7 m height of mercury remaining in the vessel
 (D) None of the given statements is correct.
42. An oil drop falls through air with a terminal velocity of $5 \times 10^{-4} \text{ ms}^{-1}$. Viscosity of oil is $1.8 \times 10^{-5} \text{ Nsm}^{-2}$ and density of oil is 900 kgm^{-3} . Neglecting density of air as compared to that of the oil, select the correct option(s).
- (A) radius of the drop is $6.2 \times 10^{-2} \text{ m}$
 (B) radius of the drop is $2.14 \times 10^{-6} \text{ m}$
 (C) terminal velocity of the drop at half of this radius is $1.25 \times 10^{-4} \text{ ms}^{-1}$
 (D) terminal velocity of the drop at half of this radius is $2.5 \times 10^{-4} \text{ ms}^{-1}$
43. An oil drop falls through air with a terminal velocity of $5 \times 10^{-4} \text{ ms}^{-1}$. If viscosity of air is $1.8 \times 10^{-5} \text{ Nsm}^{-2}$ and density of oil is 900 kgm^{-3} and density of air be ignored compared to the density of oil, then select the correct option(s).
- (A) Radius of the drop is $2.14 \times 10^{-6} \text{ m}$
 (B) Radius of the drop is $6.7 \times 10^{-6} \text{ m}$
 (C) Terminal velocity of the drop at half of this radius is $1.25 \times 10^{-4} \text{ ms}^{-1}$
 (D) Terminal velocity of the drop at half of this radius is $2.5 \times 10^{-4} \text{ ms}^{-1}$
44. A uniform rod AB of length 12 m, mass 24 kg is supported at end B by a flexible light string. A lead weight (of very small size) of 12 kg attached to the end A of the rod as shown in Figure.

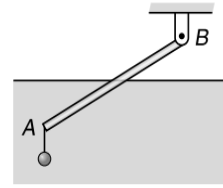

If the rod floats in water with one-half of its length submerged, $g = 10 \text{ ms}^{-2}$ and density of water is 1000 kgm^{-3} , then for this situation, select the incorrect statement(s).

- (A) The point of application of the buoyant force is passing through C (centre of mass of rod)
 (B) The tension in the string is 20 N
 (C) The tension in the string is 36 N
 (D) The volume of the rod is $6.4 \times 10^{-2} \text{ m}^3$
45. Following are some statements about buoyant force on a body placed in liquid of uniform density. Select the incorrect statement(s).
- (A) Buoyant force depends upon orientation of the concerned body inside the liquid.
 (B) Buoyant force depends upon the density of the body immersed.
 (C) Buoyant force depends on the fact whether the system is on moon or on the earth.
 (D) Buoyant force depends upon the depth at which the body (fully immersed in the liquid) is placed inside the liquid.
46. A liquid of density ρ and surface tension σ rises in a capillary tube of inner radius R . The angle of contact between the liquid and the glass is θ . The point A lies just below the meniscus in the tube and the point B lies at the outside level of liquid in the beaker as shown in Figure. If pressure at B is P_B and P_0 is atmospheric pressure, then pressure at A is equal to

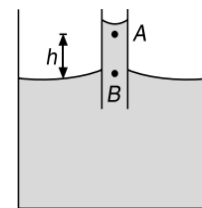

- (A) $P_B - \rho gh$ (B) $P_B - \frac{2\sigma \cos \theta}{R}$
 (C) $P_0 - \frac{2\sigma \cos \theta}{R}$ (D) $P_B - P_0$

REASONING BASED QUESTIONS

This section contains Reasoning type questions, each having four choices (A), (B), (C) and (D) out of which ONLY ONE is correct. Each question contains STATEMENT 1 and STATEMENT 2. You have to mark your answer as

- Bubble (A)** If both statements are TRUE and STATEMENT 2 is the correct explanation of STATEMENT 1.
Bubble (B) If both statements are TRUE but STATEMENT 2 is not the correct explanation of STATEMENT 1.
Bubble (C) If STATEMENT 1 is TRUE and STATEMENT 2 is FALSE.
Bubble (D) If STATEMENT 1 is FALSE but STATEMENT 2 is TRUE.

1.158 JEE Advanced Physics: Waves and Thermodynamics

- Statement-1:** A rain drop after falling through some height attains a constant velocity.
Statement-2: At constant velocity the viscous drag is just equal to its net weight.
- Statement-1:** Smaller drops of liquid resist deforming forces better than the larger drops.
Statement-2: Excess pressure inside a drop is directly proportional to its surface area.
- Statement-1:** If barometer is accelerated upwards, the level of mercury in the tube of barometer will decrease.
Statement-2: The effective value of g will increase, so upthrust will increase.
- Statement-1:** Aeroplanes are made to run on the runway before take-off, so that they acquire the necessary lift.
Statement-2: This is as per Bernoulli's theorem.
- Statement-1:** Upthrust on a solid block of iron when immersed in a lake will be less on the surface than on the bed of the lake.
Statement-2: On the surface of the lake density of water will be less than that at the bed and upthrust depends on the density of liquid.
- Statement-1:** Dust particles generally settle down in a closed room.
Statement-2: The terminal velocity is inversely proportional to the square of their radii.
- Statement-1:** Water is filled in a U-tube of different cross-sectional area on two sides as shown in Figure. Now equal amount of oil ($RD = 0.5$) is poured on two sides. Level of water on both sides will remain unchanged.

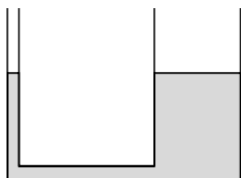

Statement-2: Same weight of oil poured on two sides will produce different pressures.

- Statement-1:** To float, a body must displace liquid whose weight is greater than actual weight of the body.
Statement-2: The body will experience no net downward force in that case.
- Statement-1:** A ball is dropped from a certain height above the free surface of an ideal fluid. When the ball enters the liquid, it may accelerate or retard.
Statement-2: Ball accelerates or retards it all depends on the density of ball and the density of liquid.

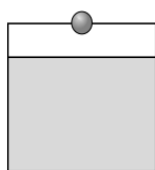

- Statement-1:** Bulk modulus of elasticity B represents incompressibility of the material.

Statement-2: $B = -\frac{\Delta P}{\Delta V/V}$, where symbols have their usual meaning.

- Statement-1:** An ideal fluid is flowing through a pipe. Speed of fluid particles is more at places where pressure is low.
Statement-2: Bernoulli's theorem can be derived from work-energy theorem.
- Statement-1:** A dam for water reservoir is built thicker at bottom than at the top.
Statement-2: Pressure of water is very large at the bottom.
- Statement-1:** From the relation $Y = \frac{Fl}{A\Delta l}$, we observe that, if length of a wire is doubled, then its Young's modulus (Y) also becomes two times.
Statement-2: Modulus of elasticity is the property of the material.
- Statement-1:** Pascal's law is the working principle of hydraulic lift.
Statement-2: Pressure = $\frac{\text{thrust}}{\text{area}}$
- Statement-1:** A needle placed carefully on the surface of water may float, whereas the ball of the same material will always sink.
Statement-2: The buoyancy of an object depends both on the material and shape of the object.
- Statement-1:** Air flows from a small bubble to a large bubble when they are connected to each other by a capillary tube.
Statement-2: The excess pressure because of surface tension inside a spherical bubble decreases as its radius increases.
- Statement-1:** A small drop of mercury is spherical but bigger drops are oval in shape.
Statement-2: Surface tension of liquid decreases with increase in temperature.
- Statement-1:** Bulk's modulus of elasticity can be defined for all three states of matter, i.e. solids liquids and gases.
Statement-2: Young's modulus is not defined for liquids and gases.
- Statement-1:** Steel is more elastic than rubber.
Statement-2: Under given deforming force, steel is deformed less than rubber.
- Statement-1:** Force of buoyancy due to atmosphere on a small body is almost zero (or negligible).
Statement-2: If a body is completely submerged in a fluid, then buoyant force is zero.
- Statement-1:** Stress is internal restoring force per unit area of a body.
Statement-2: Rubber is more elastic than steel.
- Statement-1:** At depth h below the water surface pressure is p . Then at depth $2h$ pressure will be $2p$. (Ignore density variation).
Statement-2: With depth pressure increases linearly.
- Statement-1:** If length of a rod is doubled the breaking load remains unchanged.
Statement-2: Breaking load is equal to the elastic limit.

24. **Statement-1:** On moon, barometer height will be six times compared to the height on earth.

Statement-2: Value of g on moon's surface is $\frac{1}{6}$ the value of g on earth's surface.

25. **Statement-1:** Lead is more elastic than rubber.

Statement-2: If the same load is attached to lead and rubber wires of the same cross-sectional area, the strain of lead is very much less than that of rubber.

26. **Statement-1:** Two identical conical pipes shown in figure have a drop of water. The water drop tends to move towards tapered end.

Statement-2: Excess pressure is directed towards centre of curvature and inversely proportional to radius of curvature. Net excess pressure is therefore, directed towards tapered end. So, the water drop tends to move towards tapered end.

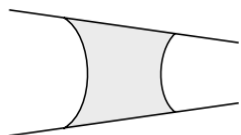

27. **Statement-1:** Finer the capillary, greater is the height to which the liquid rises in the tube.

Statement-2: This is accordance with ascent formula.

28. **Statement-1:** In the siphon shown in Figure, pressure at P is equal to atmospheric pressure.

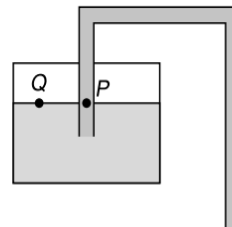

Statement-2: Pressure at Q is atmospheric pressure and points P and Q are at same levels.

29. **Statement-1:** Machine parts are jammed in winter.

Statement-2: The viscosity of lubricant used in machine parts increases at low temperature.

LINKED COMPREHENSION TYPE QUESTIONS

This section contains Linked Comprehension Type Questions or Paragraph based Questions. Each set consists of a Paragraph followed by questions. Each question has four choices (A), (B), (C) and (D), out of which only one is correct. (For the sake of competitiveness there may be a few questions that may have more than one correct options)

Comprehension 1

A large open top container of negligible mass and uniform cross-sectional area A has a small hole of cross-sectional area $\frac{A}{100}$ in its side wall near the bottom. The container is kept on a smooth horizontal floor and contains a liquid of density ρ and mass m_0 . Assuming that the liquid starts flowing out horizontally through the hole at $t = 0$. Based on the above facts, answer the following questions.

- The velocity of efflux at the hole initially is

(A) $v = \sqrt{\frac{m_0 g}{A \rho}}$	(B) $v = \sqrt{\frac{m_0 g}{2 A \rho}}$
(C) $v = \sqrt{\frac{m_0 g}{3 A \rho}}$	(D) $v = \sqrt{\frac{2 m_0 g}{A \rho}}$
- The acceleration of the container is a . Then a equals

(A) $\frac{g}{25}$	(B) $\frac{g}{50}$
(C) $\frac{g}{75}$	(D) $\frac{g}{100}$
- The velocity of the liquid when 75% of it has drained out is

(A) $\sqrt{\frac{m_0 g}{A \rho}}$	(B) $\sqrt{\frac{m_0 g}{2 A \rho}}$
(C) $\sqrt{\frac{m_0 g}{3 A \rho}}$	(D) $\sqrt{\frac{2 m_0 g}{A \rho}}$

Comprehension 2

A cube of side 10 cm having a density of 0.5 g cm^{-3} is placed in a vessel of base area $20 \text{ cm} \times 20 \text{ cm}$ as shown in Figure. A liquid of density 1 g cm^{-3} is gradually filled in the vessel at a constant rate $Q = 50 \text{ cm}^3 \text{ s}^{-1}$. Based on the information given, answer the following questions.

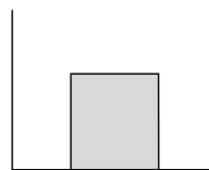

4. Graph between the normal reaction acting on cube by the vessel versus time is

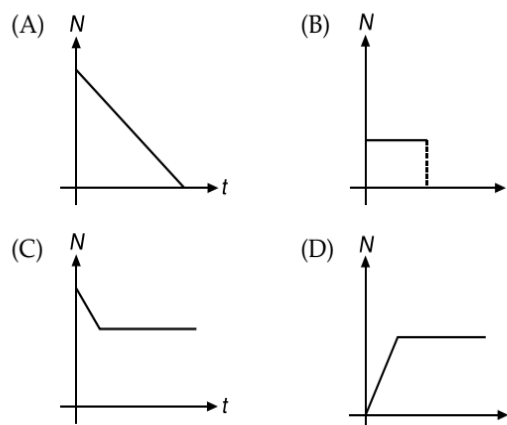

1.160 JEE Advanced Physics: Waves and Thermodynamics

5. The cube will leave contact with the vessel after
 (A) 20 s (B) 30 s
 (C) 40 s (D) 60 s

Comprehension 3

A wooden cylinder of diameter $4r$, height h and density $\frac{\rho}{3}$ is kept on a hole of diameter $2r$ of a tank, filled with water of density ρ as shown in Figure.

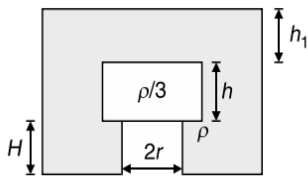

- The height of the base of the cylinder from the base of the tank is H . Based on the above facts, answer the following questions.
6. If level of the liquid starts decreasing slowly, when the level of liquid is at a height h_1 above the cylinder the block starts moving up. Then, the value of h_1 is
 (A) $\frac{4h}{9}$ (B) $\frac{5h}{9}$
 (C) $\frac{5h}{3}$ (D) remains same
7. Let the cylinder be prevented from moving up, by applying a force and water level is further decreased. Then height of water level (h_2 in figure) for which the cylinder remains in original position without application of force is

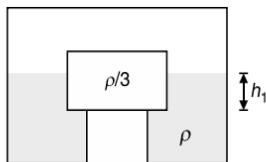

- (A) $\frac{4h}{9}$ (B) $\frac{5h}{9}$
 (C) remains same (D) $\frac{2h}{3}$
8. If height h_2 of water level is further decreased, then
 (A) cylinder will not move up and remains at its original position
 (B) for $h_2 = \frac{h}{3}$, cylinder again starts moving up
 (C) for $h_2 = \frac{h}{4}$, cylinder again starts moving up
 (D) for $h_2 = \frac{h}{5}$ cylinder again starts moving up

Comprehension 4

A liquid of density ρ and height h is filled over another liquid of density 2ρ . Two holes are made at depths h and $2h$ from the top free surface. Speeds of liquids ejecting from two holes are say v_1 and v_2 . Based on the information given, answer the following questions.

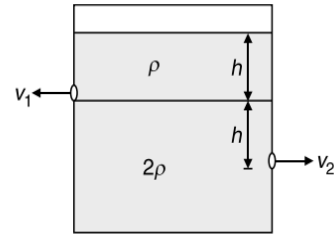

9. The ratio $\frac{v_1}{v_2}$ will be
 (A) $\sqrt{\frac{1}{3}}$ (B) $\sqrt{\frac{1}{2}}$
 (C) $\sqrt{\frac{2}{3}}$ (D) $\sqrt{\frac{4}{3}}$
10. Assume that the density of lower liquid to be increased, then
 (A) v_1 will decrease, v_2 will increase.
 (B) v_1 remains same, v_2 will decrease.
 (C) v_1 remains same, v_2 will increase.
 (D) both v_1 and v_2 decrease.

Comprehension 5

A container of large uniform cross-sectional area A resting on a horizontal surface, holds two immiscible, non-viscous and incompressible liquids of densities d and $2d$, each of height $\frac{H}{2}$ as shown in figure. The lower density liquid is open to the atmosphere having pressure P_0 .

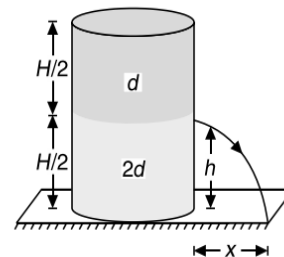

A homogeneous solid cylinder of density D , length L ($L < \frac{H}{2}$), cross-sectional area $\frac{A}{5}$ is immersed such that it floats with its axis vertical at the liquid-liquid interface with length $\frac{L}{4}$ in the denser liquid. The total pressure at the bottom of the container is P .

Based on the above facts, answer the following questions.

11. The density of the solid cylinder is
 (A) $D = \frac{5}{2}d$ (B) $D = \frac{7}{20}d$
 (C) $D = \frac{5}{4}d$ (D) $D = \frac{7}{10}d$
12. The value of P in terms of the known parameters is
 (A) $P = P_0 + \frac{gd}{2}(L + 3H)$ (B) $P = P_0 + \frac{gd}{4}(L + 6H)$
 (C) $P = P_0 + gd(L + 6H)$ (D) $P = P_0 + \frac{gd}{2}(L + 6H)$

Comprehension 6

The stress-strain relationship for a metal wire subjected to the gradual loading process is shown in Figure.

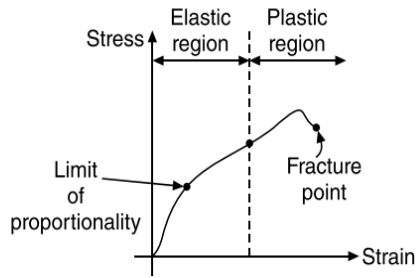

Within elastic limit, Hooke's Law is obeyed, i.e. ratio of stress to strain is constant and that constant is called the modulus of elasticity. Based on the information given, answer the following questions.

13. Two wires of same material have length and radius (L, r) and $\left(3L, \frac{r}{3}\right)$. The ratio of their Young's moduli is
 (A) 1 : 2 (B) 2 : 1
 (C) 1 : 1 (D) 2 : 3
14. Just when the yield region is crossed, the material will experience
 (A) constant stress.
 (B) breaking stress that increases.
 (C) breaking stress that decreases.
 (D) None of these
15. Consider the ratio of stress to strain to be x in elastic region and y in the region of yield, then
 (A) $x = y$ (B) $x = 2y$
 (C) $x < y$ (D) $x > y$

Comprehension 7

A uniform solid cylinder of density 0.8 gcm^{-3} floats in equilibrium in a combination of two non-mixing liquids A and B with its axis vertical. The densities of the liquids A and B are 0.7 gcm^{-3} and 1.2 gcm^{-3} , respectively. The height of liquid A is $h_A = 1.2 \text{ cm}$. The length of the part of the cylinder immersed in liquid B is $h_B = 0.8 \text{ cm}$.

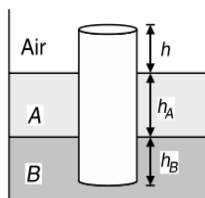

Based on the above facts, answer the following questions.

16. Net force applied by the liquid A on the cylinder is
 (A) ZERO
 (B) non-zero
 (C) non-zero and very large
 (D) cannot be determined

17. The height of the portion of cylinder in air is
 (A) $h = 1 \text{ cm}$
 (B) $h = 0.75 \text{ cm}$
 (C) $h = 0.25 \text{ cm}$
 (D) $h = 0 \text{ cm}$
18. The cylinder is depressed in such a manner so that its top surface is just below the upper surface of the liquid A and is then released. The acceleration of the cylinder immediately after it is released is
 (A) $\frac{g}{12}$ (B) $\frac{g}{6}$
 (C) $\frac{g}{3}$ (D) $\frac{g}{2}$

Comprehension 8

Liquid is filled in a vessel having a square base ($2 \text{ m} \times 2 \text{ m}$) up to a height of 2 m . The vessel has an orifice that is sealed tightly such that no liquid could emerge from it as shown in Figure-(i). Now, the vessel is tilted such that it makes an angle of 30° with the horizontal and the water in the vessel is just not spilt over the edge of the mouth of vessel as shown in Figure-(ii). Based on the information given, answer the following questions.

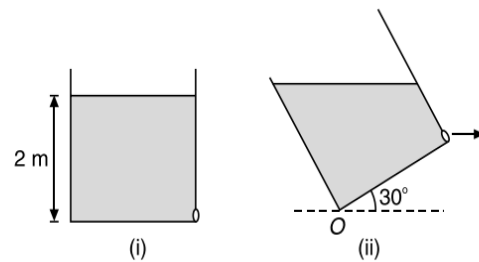

19. The speed of efflux of the liquid coming out of the orifice, when the orifice in Figure-2 is opened is nearly
 (A) 3 ms^{-1} (B) 4 ms^{-1}
 (C) 5 ms^{-1} (D) 6 ms^{-1}
20. The time when liquid hits the ground is
 (A) $\frac{1}{\sqrt{2}} \text{ s}$ (B) $\frac{1}{\sqrt{3}} \text{ s}$
 (C) $\frac{1}{\sqrt{5}} \text{ s}$ (D) $\sqrt{2} \text{ s}$
21. The distance from point O, where the liquid strikes the ground is
 (A) $\sqrt{3} \text{ m}$ (B) $\sqrt{5} \text{ m}$
 (C) $(\sqrt{5} + \sqrt{3}) \text{ m}$ (D) $(\sqrt{5} - \sqrt{3}) \text{ m}$

Comprehension 9

A U-tube of base length L contains a liquid of density ρ in it. The tube is rotated about one of its vertical limbs with angular velocity ω as shown. The diameter of the tube is negligibly small as compared to the length of the tube. Take P_0 as the atmospheric pressure.

1.162 JEE Advanced Physics: Waves and Thermodynamics

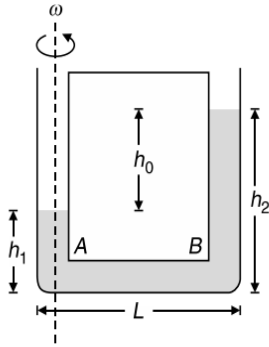

Based on the above facts, answer the following questions.

22. What is the force at B due to rotation of the U-tube?

- (A) $A\rho\omega^2$ (B) $A\rho\omega^2L^2$
 (C) $\frac{A\rho\omega^2L^2}{2}$ (D) $\frac{A\rho\omega^2L^2}{4}$

23. What is the pressure at B from the left side?

- (A) $P_0 + h_1\rho g$ (B) $P_0 + \frac{h_1\rho g}{2}$
 (C) $2P_0 + h_1\rho g$ (D) $P_0 + h_1\rho g + \frac{\rho\omega^2L^2}{2}$

24. The value of h_0 is

- (A) $\frac{\omega^2L}{2g}$ (B) $\frac{\omega^2L^2}{2g}$
 (C) $\frac{\omega^2L^2}{3g}$ (D) $\frac{\omega^2L^2}{4g}$

Comprehension 10

In the arrangement shown, a siphon tube is discharging a liquid of density 900 kg m^{-3} . Assuming the atmospheric pressure to be $P_0 = 1.01 \times 10^5 \text{ Nm}^{-2}$, answer the following questions.

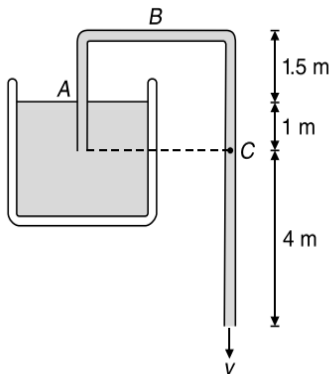

25. The speed of liquid through the siphon is

- (A) 12 ms^{-1} (B) 10 ms^{-1}
 (C) 8 ms^{-1} (D) 6 ms^{-1}

26. The pressure at point B is

- (A) $2.50 \times 10^4 \text{ Nm}^{-2}$ (B) $2 \times 10^9 \text{ Nm}^{-2}$
 (C) $4.25 \times 10^4 \text{ Nm}^{-2}$ (D) $6.25 \times 10^4 \text{ Nm}^{-2}$

27. The pressure at point C is

- (A) $10.5 \times 10^4 \text{ Nm}^{-2}$ (B) $8 \times 10^4 \text{ Nm}^{-2}$
 (C) $6.5 \times 10^4 \text{ Nm}^{-2}$ (D) $5.5 \times 10^4 \text{ Nm}^{-2}$

Comprehension 11

A small block of weight W is kept inside a vessel filled with some liquid with the help of a string attached to the bottom of the vessel as shown in Figure. The tension in the string is $\frac{W}{2}$ and this entire situation is referred to as first case.

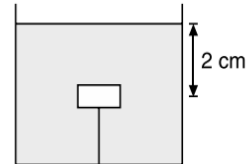

In the second case, if the weight of the block is doubled, then it is observed that tension in the string to keep the block in equilibrium becomes x times the tension in the first case. Also, when the string is cut, then time taken by the block to reach the liquid surface becomes y times the value calculated in the first case. Based on the information given, answer the following questions.

28. If the string is cut, then the time taken by the block to reach the surface of the liquid is

- (A) $\frac{1}{\sqrt{5}} \text{ s}$ (B) $\sqrt{5} \text{ s}$
 (C) $\sqrt{3} \text{ s}$ (D) $\frac{2}{\sqrt{5}} \text{ s}$

29. The ratio of x to y is

- (A) 1 (B) 2
 (C) 3 (D) 4

Comprehension 12

A non-viscous liquid of constant density 1000 kg m^{-3} flows in streamline motion along a tube of variable cross-section. The tube is kept inclined in the vertical plane as shown in the figure. The area of cross-section of the tube at two points P and Q at heights of 2 m and 5 m are respectively $4 \times 10^{-3} \text{ m}^2$ and $8 \times 10^{-3} \text{ m}^2$. The velocity of the liquid at point P is 1 ms^{-1} .

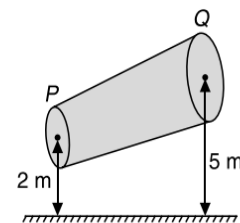

Based on the above facts, answer the following questions.

30. The velocity of the liquid at the point Q is

- (A) 0.5 ms^{-1} (B) 1 ms^{-1}
 (C) 2 ms^{-1} (D) 4 ms^{-1}

31. Work done per unit volume by the pressure forces as the liquid goes from P to Q is

- (A) 25290 J m^{-3} (B) 29250 J m^{-3}
 (C) 29025 J m^{-3} (D) 25029 J m^{-3}

32. Work done per unit volume by the gravitational forces as the liquid flows from P to Q is
 (A) 29004 Jm^{-3} (B) 29400 Jm^{-3}
 (C) 24900 Jm^{-3} (D) 24009 Jm^{-3}

Comprehension 13

A cylindrical container of length L is full to the brim with a liquid which has mass density ρ . The cylinder is placed on a weighing scale and the scale reading is observed to be W . A light ball of mass m , volume V capable of floating on the liquid (when allowed to do so), is pushed gently down and halfway below the surface of the liquid with a rigid rod of negligible volume as shown in Case-1. If instead of being pushed down by a rod, the ball is held in place by a thin string attached to the bottom of the container as shown in Case-2, then answer the following questions.

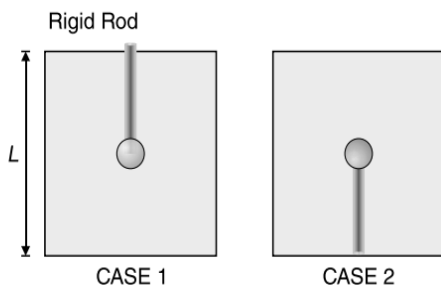

33. Mass M of the liquid which overflows while the ball was being pushed into the liquid is
 (A) ρV (B) m
 (C) $m - \rho V$ (D) $m + \rho V$
34. Reading of the scale when the ball is fully immersed (in Case-1) is
 (A) $W - V\rho g$ (B) W
 (C) $W + mg - V\rho g$ (D) $W + mg$
35. If instead of being pushed down by a rod, the ball is held in place by a thin string attached to the bottom of the container as shown on the right. What is the tension T in the string?
 (A) $(\rho V - m)g$ (B) ρVg
 (C) mg (D) None of these
36. Reading of the scale in Case-2 is
 (A) $W - V\rho g$ (B) W
 (C) $W + mg - V\rho g$ (D) $W + mg$

Comprehension 14

A container of large uniform cross-sectional area A resting on a horizontal surface, holds two immiscible, non-viscous and incompressible liquids of densities d and $2d$, each of height $\frac{H}{2}$ as shown in Figure.

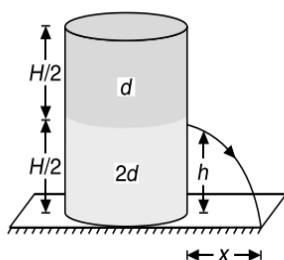

The lower density liquid is open to the atmosphere having pressure P_0 . A tiny hole of area s ($s \ll A$) is punched on the vertical side of the container at a height h ($h < \frac{H}{2}$). Neglecting the air resistance in these calculations. Based on the above facts, answer the following questions.

37. The initial speed of efflux of the liquid at the hole is
 (A) $v = \sqrt{\left(\frac{3H}{2} - 2h\right)g}$ (B) $v = \sqrt{(3H - 2h)g}$
 (C) $v = \sqrt{\left(2H - \frac{3h}{2}\right)g}$ (D) $v = \sqrt{(2H - 3h)g}$
38. The horizontal distance x travelled by the liquid initially is
 (A) $x = \sqrt{h(4H - 3h)}$
 (B) $x = \sqrt{h(3H - 4h)}$
 (C) $x = \sqrt{3h(H - 4h)}$
 (D) $x = \sqrt{4h(H - 3h)}$
39. The height h_m at which the hole should be punched so that the liquid travels the maximum distance (x_m) initially is
 (A) $h_m = \frac{H}{4}$ (B) $h_m = \frac{3H}{8}$
 (C) $h_m = \frac{H}{2}$ (D) $h_m = \frac{H}{8}$
40. The corresponding value of x_m for the condition achieved is
 (A) $x_m = \frac{H}{4}$ (B) $x_m = \frac{H}{2}$
 (C) $x_m = \frac{3H}{4}$ (D) $x_m = H$

Comprehension 15

The axle of a pulley of mass 1 kg is attached to the end of an elastic string of length 1 m , cross-sectional area 10^{-3} m^2 and Young's modulus $2 \times 10^5 \text{ Nm}^{-2}$, whose other end is fixed to the ceiling. A rope of negligible mass is placed on the pulley such that its left end is fixed to the ground and its right end is hanging freely, from the pulley which is at rest in equilibrium. Now, the free end A of the rope is subjected to pulling with constant force $F = 10 \text{ N}$. Friction between the rope and the pulley can be neglected. (Given, $g = 10 \text{ ms}^{-2}$)

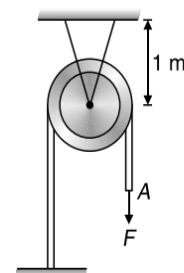

41. The elongation of the string before applying force is
 (A) 50 cm (B) 5 cm
 (C) 0.5 cm (D) 0.05 cm

1.164 JEE Advanced Physics: Waves and Thermodynamics

42. The greatest elongation of the string is
 (A) 35 cm (B) 30 cm
 (C) 25 cm (D) 20 cm
43. The maximum displacement of point A after applying F is
 (A) 70 cm (B) 60 cm
 (C) 40 cm (D) 50 cm

MATRIX MATCH/COLUMN MATCH TYPE QUESTIONS

Each question in this section contains statements given in two columns, which have to be matched. The statements in COLUMN-I are labelled A, B, C and D, while the statements in COLUMN-II are labelled p, q, r, s (and t). Any given statement in COLUMN-I can have correct matching with **ONE OR MORE** statement(s) in COLUMN-II. The appropriate bubbles corresponding to the answers to these questions have to be darkened as illustrated in the following examples:

If the correct matches are $A \rightarrow p, s$ and t ; $B \rightarrow q$ and r ; $C \rightarrow p$ and q ; and $D \rightarrow s$ and t ; then the correct darkening of bubbles will look like the following:

	p	q	r	s	t
A	<input checked="" type="checkbox"/>	<input type="checkbox"/>	<input type="checkbox"/>	<input checked="" type="checkbox"/>	<input checked="" type="checkbox"/>
B	<input type="checkbox"/>	<input checked="" type="checkbox"/>	<input checked="" type="checkbox"/>	<input type="checkbox"/>	<input type="checkbox"/>
C	<input checked="" type="checkbox"/>	<input checked="" type="checkbox"/>	<input type="checkbox"/>	<input type="checkbox"/>	<input type="checkbox"/>
D	<input type="checkbox"/>	<input type="checkbox"/>	<input type="checkbox"/>	<input checked="" type="checkbox"/>	<input checked="" type="checkbox"/>

1. The cubical container completely filled with water is given an acceleration $\vec{a} = a_0\hat{i} + a_0\hat{j} + a_0\hat{k}$ in a gravity free space. Compare the situations in COLUMN-I to the respective conclusions in COLUMN-II.

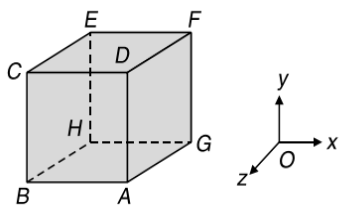

COLUMN-I	COLUMN-II
(A) Pressure at point A is	(p) less than pressure at point G
(B) Pressure at point D is	(q) less than pressure at point F
(C) Pressure at point E is	(r) greater than pressure at point C
(D) Pressure at point H is	(s) greater than pressure at point B
	(t) equal to pressure at point F

2. An ideal liquid is flowing through a pipe of non-uniform cross-section. Match the quantities in COLUMN-I to their respective match in COLUMN-II.

COLUMN-I	COLUMN-II
(A) Rate of flow of liquid	(p) more
(B) Speed of liquid at the narrow cross-section of pipe	(q) less
(C) Speed of liquid at the broader cross-section of pipe	(r) positive

COLUMN-I	COLUMN-II
(D) ressure difference between the narrow and broad cross-section of the pipe	(s) negative
	(t) constant

3. Match the relations and laws related to fluids given in COLUMN-I, to the physical reasons behind them given in COLUMN-II.

COLUMN-I	COLUMN-II
(A) Stoke's law	(p) behaviour of free surface of liquid like a stretched elastic membrane.
(B) Equation of continuity	(q) force of viscosity on a spherical body.
(C) Bernoulli's theorem	(r) conservation of mass
(D) Surface tension	(s) conservation of energy

4. Match the states of matter in COLUMN-I with the respective characteristics in COLUMN-II.

COLUMN-I	COLUMN-II
(A) Steel	(p) Young's modulus of elasticity
(B) Water	(q) Bulk modulus of elasticity
(C) Hydrogen gas filled in a chamber	(r) Shear modulus of elasticity
(D) Oil	(s) Surface Tension

(Continued)

5. Consider a wire having length L , cross-sectional area A and Young's modulus Y . Match the details in COLUMN-I with the respective information given in COLUMN-II.

COLUMN-I	COLUMN-II
(A) Let us suspend the wire vertically from a rigid supported and attach a mass m at its lower end. If the mass is slightly pulled down and released, it executes S.H.M. The time period will depend on	(p) Young's Modulus (Y)
(B) If the given wire is fixed between two rigid supports and its temperature is increased thermal stress that develops in the rod will depend on	(q) Extension (x)
(C) Work done in stretching the wire to a length $L + x$ depends on	(r) Length (L)
(D) If the wire is pulled at its ends by equal and opposite forces of magnitude F so that it undergoes an elongation x , according to Hooke's law, $F = kx$, where k is the force constant. Force constant (k) of the wire will depend on	(s) Area of cross-section (A)
	(t) Independent of elongation (x)

6. COLUMN-I contains different arrangements and COLUMN-II contains capillary rise of water in those arrangements. If the surface tension of water is T and density is ρ , match the following.

COLUMN-I	COLUMN-II
(A) Silver tube of radius r immersed in water	(p) $\frac{2T}{r\rho g}$
(B) Glass tube of radius r immersed in water	(q) $\frac{4T}{r\rho g}$
(C) Hollow co-axial cylinder made of glass, having inner and outer radius r and $2r$ respectively immersed in water	(r) $\frac{3T}{2r\rho g}$
(D) Two parallel glass plate separated by distance r immersed in water	(s) ZERO

7. Match the relations in COLUMN-I to their respective SI units given in COLUMN-II.

COLUMN-I	COLUMN-II
(A) $\frac{(\text{Stress})^2}{Y}$	(p) J
(B) $\frac{YA}{l}$	(q) Nm^{-1}
(C) Yl^3	(r) Jm^{-3}
(D) $\frac{Fl}{AY}$	(s) m

8. Match the phenomenon and equations in COLUMN-I with their respective match in COLUMN-II.

COLUMN-I	COLUMN-II
(A) Excess pressure inside a drop of radius R	(p) decreases with increase in temperature
(B) Excess pressure inside a soap bubble of radius R	(q) $\frac{2T}{R}$
(C) Excess pressure inside an air cavity of radius R	(r) $\frac{4T}{R}$
(D) Surface tension	(s) decreases with increase in radius

9. Match the physical quantities in COLUMN-I with the respective dimensional formulae in COLUMN-II.

COLUMN-I	COLUMN-II
(A) Pressure per unit speed gradient Coefficient of viscosity	(p) $ML^{-1}T^{-2}$
(B) Surface tension	(q) $M^0L^0T^0$
(C) Modulus of elasticity	(r) $ML^{-1}T^{-1}$
(D) Energy per unit volume of a fluid	(s) MLT^{-2}
(E) Reynold's Number	(t) MT^{-2}

10. Match the contents of COLUMN-I to the contents given in COLUMN-II.

COLUMN-I	COLUMN-II
(A) Equation of continuity	(p) Non-viscous flow
(B) Bernoulli's equation	(q) Steady flow

(Continued)

1.166 JEE Advanced Physics: Waves and Thermodynamics

COLUMN-I	COLUMN-II
(C) Velocity at a given point is constant with	(r) Incompressible liquid
(D) Ideal flow	(s) Irrotational flow

11. A cylinder of weight W is floating in two liquids. A force F_1 acts at the top of cylinder and a force F_2 acts at the bottom of the cylinder as shown in Figure. Match the following two columns.

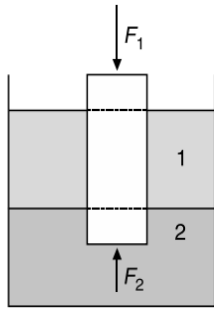

COLUMN-I	COLUMN-II
(A) Net force on cylinder from liquid-1	(p) Zero
(B) $F_2 - F_1$	(q) W
(C) Net force on cylinder from liquid-2	(r) Net upthrust
(D) Net force on cylinder from atmosphere	(s) None of these

12. For an incompressible liquid match the contents of COLUMN-I with their respective equations in COLUMN-II.

COLUMN-I	COLUMN-II
(A) Equation of continuity	(p) $\Delta P = h\rho g$
(B) Bernoulli's equation	(q) $v = \sqrt{2gh}$
(C) Torricelli's theorem	(r) $A_1v_1 = A_2v_2$
(D) Hydrostatic pressure	(s) $P + \rho gh + \frac{1}{2}\rho v^2 = \text{constant}$

13. Match the arguments in COLUMN-I to the capillary rise and shape of droplets on a plate due to surface tension shown in COLUMN-II.

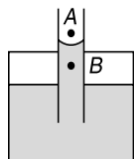
COLUMN-I	COLUMN-II
(A) Adhesive force is greater than cohesive force	(p) 

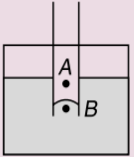
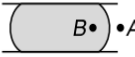
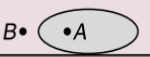
COLUMN-I	COLUMN-II
(B) Cohesive force is greater than adhesive force	(q) 
(C) Pressure at A greater pressure at B	(r) A mercury drop is pressed between two parallel plates of glass 
(D) Pressure at B greater pressure at A	(s) 

14. Three holes A, B and C are made at depths 1 m, 2 m and 5 m as shown. Total height of liquid in the container is 9 m. Let v is the speed with which liquid comes out of the hole and R the range on ground. Match the following two columns.

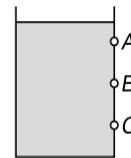



COLUMN-I	COLUMN-II
(A) v is maximum for	(p) hole A
(B) v is minimum for	(q) hole B
(C) R is maximum for	(r) hole C
(D) R is minimum for	(s) will depend on density of liquid

15. Match the contents of COLUMN-I to the respective contents in COLUMN-II.

COLUMN-I	COLUMN-II
(A) Mercury Barometer	(p) Measures difference of absolute pressure and atmospheric pressure
(B) Pascal's law	(q) Measures absolute pressure
(C) Pressure gauge	(r) Measures atmospheric pressure
(D) Manometer	(s) The change in pressure is transferred to the entire liquid without being diminished in magnitude

16. A block of wood is floating on the surface of water inside a container at rest. Now the container is given some acceleration as shown in COLUMN-I. Some observation are shown in COLUMN-II. Match the columns.

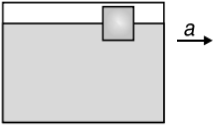
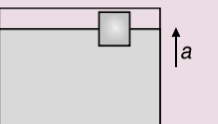
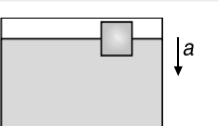
(Continued)

COLUMN-I	COLUMN-II
(A) 	(p) Buoyant force on the block increases
(B) 	(q) Buoyant force on the block decreases
(C) 	(r) Pressure at the bottom of the container is non-uniform
(D) 	(s) Pressure at the bottom of the container is uniform

17. In the arrangement shown, the speed of liquid coming out from the orifice is v , time taken by the liquid to hit the ground is t and distance at which the liquid hits the ground is R . If the vessel is taken to a mountain, match the following, (consider all cases which might possible)

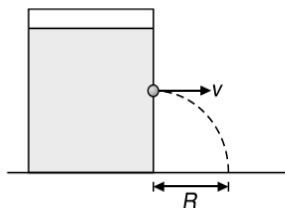

COLUMN-I	COLUMN-II
(A) v	(p) will increase
(B) t	(q) will decrease

COLUMN-I	COLUMN-II
(C) R	(r) will remain same
(D) R_{\max}	(s) when the orifice is at the middle of the beaker
	(t) when the orifice is at the middle of the liquid level that fills the beaker.

18. A uniform solid cube is floating in a liquid as shown in Figure, with part x inside the liquid. Some changes in parameters are mentioned in COLUMN-I. Assuming no other changes, match the following

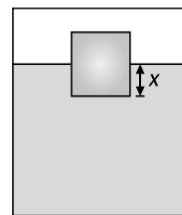

COLUMN-I	COLUMN-II
(A) If density of the liquid is increased, x will	(p) Increase
(B) If height of the cube is increased keeping base area and density same, x will	(q) Decreases
(C) if the whole system is accelerated upward, then x will	(r) Remain same
(D) If the cube is replaced by another cube of same size but lesser density, x will	(s) May increase or decrease

INTEGER/NUMERICAL ANSWER TYPE QUESTIONS

In this section, the answer to each question is a numerical value obtained after doing series of calculations based on the data given in the question(s).

1. A vertical U-tube with the two limbs 0.74 m apart is filled with water and rotated about a vertical axis 0.5 m from the left limb, as shown in Figure. Determine the difference in elevation of the water levels in the two limbs in centimetre when the speed of rotation is 60 rpm.

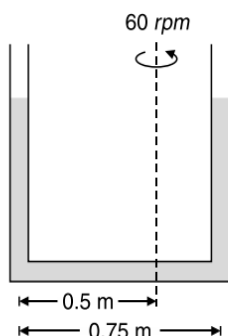

2. The pressure increases by $1.0 \times 10^4 \text{ Nm}^{-2}$ for every meter of depth beneath the surface of the ocean. At what depth (in metre) does the volume of a Pyrex glass cube, $1.0 \times 10^{-2} \text{ m}$ on an edge at the ocean's surface, decrease by $1.0 \times 10^{-10} \text{ m}^3$? Assume the Bulk's modulus to be $2.6 \times 10^{10} \text{ Nm}^{-2}$.
3. Calculate the increment in the length (in micrometre) of a steel wire of length 5 m and radius 6 mm under its own weight. Assume density of steel to be 8000 kgm^{-3} , $g = 9.8 \text{ ms}^{-2}$ and Young's modulus of steel to be $2 \times 10^{11} \text{ Nm}^{-2}$. Also calculate energy stored in the wire in microjoule.
4. When the load on a wire is increased slowly from 3 kgwt to 5 kgwt, the elongation increases from 0.61 mm to 1.02 mm. Calculate the work done (in millijoule) during the extension of the wire.

1.168 JEE Advanced Physics: Waves and Thermodynamics

5. A siphon has a uniform circular base of diameter $\frac{8}{\sqrt{\pi}}$ cm with its crest A lying at 1.8 m above the water level as shown in Figure.

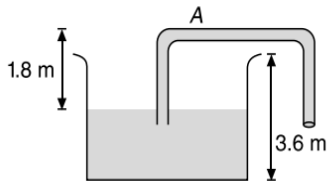

Calculate the velocity of flow in ms^{-1} , discharge rate of the flow in cm^3s^{-1} and the absolute pressure at the crest level A in kNm^{-2} if atmospheric pressure is 100 kNm^{-2} and $g = 10 \text{ ms}^{-2}$.

6. A glass tube of 1 mm bore is dipped vertically into a container of mercury, with its lower end 2 cm below the mercury surface. The gauge pressure of air in the tube required to blow a hemispherical bubble at its lower end is x mm of Hg. Assuming that the density of mercury is 13600 kgm^{-3} and its surface tension is 0.465 Nm^{-1} , calculate x .
7. A block of mass m is kept over a fixed smooth wedge. Block is attached to a sphere of same mass through fixed massless pulleys P_1 and P_2 . Sphere is dipped inside the water as shown. If specific gravity of material of sphere is 2. Calculate the acceleration of sphere.

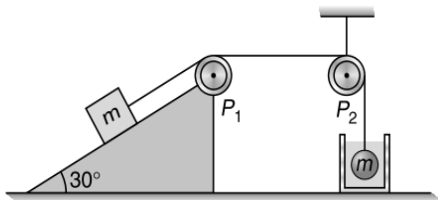

8. Two wires of diameter 0.25 cm, one made of steel and the other made of brass are loaded as shown in Figure.

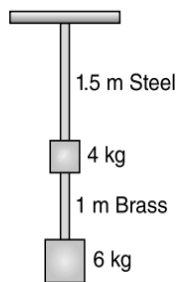

The unloaded length of steel wire is 1.5 m and that of brass wire is 1.0 m. Calculate the elongations of the steel and the brass wires in mm. (Young's modulus for brass is $9 \times 10^{10} \text{ Nm}^{-2}$ and Young's modulus for steel is $2 \times 10^{11} \text{ Nm}^{-2}$)

9. Air is streaming past a horizontal aeroplane wing such that its speed is 120 ms^{-1} over the upper surface and 90 ms^{-1} at the lower surface. If the density of air is 1.3 kgm^{-3} , the pressure difference between the top and bottom of the wing is x kPa. Calculate x . If the wing is 10 m long and has an

average width 2 m, calculate the lift force acting on the wing in kN.

10. Between each pair of vertebrae in the spinal column is a cylindrical disc of cartilage. Typically, this disc has a radius of about $3.0 \times 10^{-2} \text{ m}$ and a thickness of about $7.0 \times 10^{-3} \text{ m}$. The shear modulus of cartilage is $1.2 \times 10^7 \text{ Nm}^{-2}$. Suppose that a shearing force of magnitude 11 N is applied parallel to the top surface of the disc while the bottom surface remains fixed in place. How far does the top surface move (in micrometre) relative of the bottom surface?
11. A cylindrical steel wire of 3 m length is to stretch no more than 0.2 cm when a tensile force of 400 N is applied to each end of the wire. Calculate the minimum diameter of the wire (in mm) required for the purpose. Given $Y_{\text{steel}} = 2.1 \times 10^{11} \text{ Nm}^{-2}$.
12. Calculate the density of water, in kgm^{-3} , at a depth where the pressure is 501 atm. Given that the density of water at the surface is $1.0 \times 10^3 \text{ kgm}^{-3}$, Bulk modulus of water is $2.0 \times 10^9 \text{ Pa}$ and the atmospheric pressure is $1 \text{ atm} = 1.01 \times 10^5 \text{ Pa}$.
13. A cylindrical vessel filled with water up to a height of 2 m stands on a horizontal plane. The side wall of the vessel has a plugged circular hole touching the bottom. Find the minimum diameter of the hole (in centimetre) so that the vessel begins to move on the floor when the plug is removed. The coefficient of friction between the bottom of the vessel and the plane is 0.4 and total mass of water plus vessel is 100 kg.
14. A wire having a length L and cross-sectional area A is suspended at one of its ends from a ceiling. Density and Young's modulus of material of the wire are ρ and Y , respectively. Its strain energy due to its own weight is $\frac{\rho^2 g^2 A L^3}{pY}$. Calculate the value of p .
15. A rod 100 cm long and of $2 \text{ cm} \times 2 \text{ cm}$ cross-section is subjected to a pull of 1000 kg force. If the modulus of elasticity of the material is $2.0 \times 10^6 \text{ kgcm}^{-2}$, determine the elongation of the rod in mm.
16. Spherical particles of pollen are shaken up in water and allowed to settle. The depth of water is $2 \times 10^{-2} \text{ m}$. Calculate the diameter of the largest particle, in μm remaining in suspension one hour later. Density of pollen = $1.8 \times 10^3 \text{ kgm}^{-3}$, viscosity of water is 1×10^{-2} poise and density of water is $1 \times 10^{-5} \text{ kgm}^{-3}$.
17. Two wires shown in figure are made of the same material which has a breaking stress of $8 \times 10^8 \text{ Nm}^{-2}$. The area of cross-section of the upper wire is 0.006 cm^2 and that of the lower wire is 0.003 cm^2 . The mass $m_1 = 10 \text{ kg}$, $m_2 = 20 \text{ kg}$ and the hanger is light. Calculate the maximum load (in kg) that can be put on the hanger without breaking a wire. Which wire will break first if the load is increased? (Take $g = 10 \text{ ms}^{-2}$).

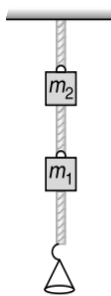

18. A steel rod of cross-sectional area 1 m^2 is acted upon by forces shown in Figure. Determine the total elongation of the bar in micrometre. Take $Y = 2.0 \times 10^{11} \text{ Nm}^{-2}$.

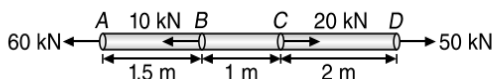

19. If the elastic limit of copper is $1.5 \times 10^8 \text{ Nm}^{-2}$, determine the minimum diameter a copper wire (in mm) can have under a load of 10.0 kg , if its elastic limit is not to be exceeded.
20. Water is flowing through a horizontal tube of non-uniform cross section. At a place the radius of the tube is 1.0 cm and velocity of water is 2.0 ms^{-1} . What will be the velocity of water, in cms^{-1} , where the radius of the pipe is 2.0 cm ?
21. A water pipe with an internal diameter of 2.5 cm carries water at ground floor of a house with velocity 3 ms^{-1} and at pressure 317.6 kPa . Another pipe of internal diameter 1.25 cm is connected to it and takes water to the first floor 25 m above ground. Calculate the velocity in ms^{-1} and water pressure at first floor in Nm^{-2} .
22. The elastic limit and ultimate strength for steel is $2.48 \times 10^8 \text{ Pa}$ and $4.89 \times 10^8 \text{ Pa}$ respectively. A steel wire of length 10 m and cross-sectional diameter 2 mm is subjected to longitudinal tensile stress. If Young's modulus of steel is $Y = 2 \times 10^{11} \text{ Pa}$, then calculate the maximum elongation (in cm) that can be produced in the wire without permanently deforming it and the force (in newton) required to produce this extension. Also calculate the maximum stretching force (in kilonewton) that can be applied without breaking the wire.
23. Calculate the approximate change in density, in kgm^{-3} , of water in a lake at a depth of 400 m below the surface. The density of water at the surface is 1030 kgm^{-3} and bulk modulus of water is $2 \times 10^9 \text{ Nm}^{-2}$.
24. The liquids shown in figure in the two limbs of the tube are mercury (specific gravity = 13.6) and water.

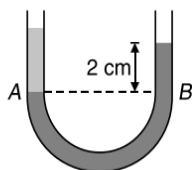

If difference of heights of the mercury column in the two limbs of the tube is 2 cm , calculate the height h of the water column in cm.

25. A cube of mass $m = 800 \text{ g}$ floats on the surface of water such that water wets it completely. The cube is 10 cm on each edge. Calculate the additional distance in μm through which it buoyed up or down due to the surface tension of water. Assume that the surface tension of water is 0.07 Nm^{-1} and $g = 10 \text{ ms}^{-2}$.
26. A 0.1 kg mass is suspended from a wire of negligible mass. The length of the wire is 1 m and its cross-sectional area is $4.9 \times 10^{-7} \text{ m}^2$. If the mass is pulled a little in the vertically downward direction and released, it performs SHM with angular frequency 140 rads^{-1} . If the Young's modulus of the material of the wire is $x \times 10^9 \text{ Nm}^{-2}$, find the value of x .
27. Two stretched cables both experience the same stress. The first cable has a radius of $3.5 \times 10^{-3} \text{ m}$ and is subject to a stretching force of 270 N . The radius of the second cable is $5.1 \times 10^{-3} \text{ m}$. Determine the stretching force (in newton) acting on the second cable.
28. A metallic sphere of radius 1 mm and density 10^4 kgm^{-3} enters a tank of water, after a free fall through distance of h in the earth's gravitational field. If its velocity remains unchanged after entering water, calculate the value of h in metre, if coefficient of viscosity of water is $1.0 \times 10^{-3} \text{ N s}^{-1} \text{ m}^2$, $g = 10 \text{ ms}^{-2}$ and density of water is 10^3 kgm^{-3} .
29. A cast iron column has internal diameter of 200 mm . Calculate the minimum external diameter of the column (in mm) so that it may carry a load of 1.6 MN without the stress exceeding 90 Nmm^{-2} .
30. A river of width 12 m flowing at 20 kmh^{-1} mixes with another river of width 8 m flowing at 16 kmh^{-1} and spreads in another stream of width 16 m . Calculate the flow velocity in kmh^{-1} of water after mixing, assuming the depth of river are same.
31. A sphere of radius 10 cm and mass 25 kg is attached to the lower end of a steel wire of length 5 m and diameter 4 mm which is suspended from the ceiling of a room. The point of support is 521 cm above the floor. When the sphere is set swinging as a simple pendulum, its lowest point just grazes the floor. Calculate the velocity of the ball, rounded off to the nearest integer in ms^{-1} , at its lowest position ($Y_{\text{steel}} = 2 \times 10^{11} \text{ Nm}^{-2}$).
32. The limiting stress of a typical human bone is $0.9 \times 10^8 \text{ Nm}^{-2}$ while Young's modulus is $1.4 \times 10^{10} \text{ Nm}^{-2}$. Calculate the energy (in joule) that can be absorbed by two leg bones (without breaking) if each has a typical length of 50 cm and an average cross-sectional area of 5 cm^2 .
33. A long cylindrical tank of cross-sectional area 0.5 m^2 is filled with water. It has a small hole at a height 50 cm from the bottom. A movable piston of cross-sectional area almost equal to 0.5 m^2 is fitted on the top of the tank such that it can slide in the tank freely. A load of 20 kg is applied on the top of the water by piston, as shown in Figure. Calculate the speed of the water jet (in ms^{-1}) with which it hits the surface when piston is 1 m above the bottom. (Ignore the mass of the piston).

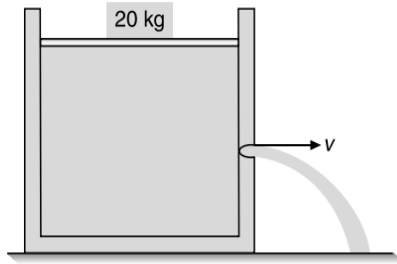
1.170 JEE Advanced Physics: Waves and Thermodynamics

34. In a horizontal pipe line of uniform area of cross section, the pressure falls by 8 Nm^{-2} between two points separated by a distance of 1 km. Calculate the change in kinetic energy per unit mass (in millijoule per kg) of the oil flowing at these points if density of oil is 800 kgm^{-3} .
35. A 6 kg weight is fastened to the end of a steel wire of unstretched length 60 cm. It is whirled in a vertical circle and has an angular velocity of 2 revs^{-1} at the bottom of the circle. The area of cross-section of the wire is 0.05 cm^2 . Calculate the elongation of the wire (in mm) when the weight is at the lowest point of the path. Young's modulus of steel = $2 \times 10^{11} \text{ Nm}^{-2}$.
36. A mild steel wire of length 1.0 m and cross-sectional area $0.50 \times 10^{-2} \text{ cm}^2$ is stretched well within its elastic limit horizontally between two pillars. A mass of 100 g is suspended from the midpoint of the wire. Calculate the depression at the midpoint in metre. ($Y_{\text{steel}} = 200 \text{ GPa}$)
37. The elastic limit of a steel cable is $3 \times 10^8 \text{ Nm}^{-2}$ and the cross-section area is 4 cm^2 . Calculate the maximum

upward acceleration, in ms^{-2} , that can be given to a 900 kg elevator supported by the cable if the stress is not to exceed one third of the elastic limit.

38. In an experimental model of the Venturimeter, the diameter of the pipe is 4 cm and that of constriction is 3 cm. With water filling the pipe and flowing at a certain rate, the height of the liquids in the pressure tube is 20 cm at the pipe and 15 cm at the constrictions. Calculate the discharge rate of the liquid, in cm^3s^{-1} rounded off to the nearest integer.
39. A wire of length 3 m, diameter 0.4 mm and Young's modulus $8 \times 10^{10} \text{ Nm}^{-2}$ is suspended from a point and supports a heavy cylinder of volume 10^{-3} m^3 at its lower end. Calculate the decrease in length (in mm) when the metal cylinder is immersed in a liquid of density 800 kgm^{-3} .
40. In a hospital, a patient receives a 500 cm^3 blood transfusion through a needle with a length of 5 cm and inner radius of 0.03 cm. If the blood bag is kept 85 cm above the needle, calculate the time in minute for which the transfusion takes place. Given that the viscosity of blood is 0.017 poise, density of blood is 1.02 gcm^{-3} and $g = 9.8 \text{ ms}^{-2}$.
41. A uniform ring of radius R and made up of a wire of cross-sectional radius r is rotated about its axis with a frequency f . If density of the wire is ρ and Young's modulus is Y . The fractional change in radius of the ring is $a \left(\frac{f^2 R^2 \rho}{Y} \right)$. Take $\pi^2 \approx 10$.

ARCHIVE: JEE MAIN
1. [Online September 2020]

A cylindrical vessel containing a liquid is rotated about its axis so that the liquid rises at its sides as shown in Figure. The radius of vessel is 5 cm and the angular speed of rotation is $\omega \text{ rads}^{-1}$. The difference in the height, h (in cm) of liquid at the center of vessel and at the side will be

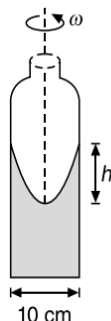

- (A) $\frac{25\omega^2}{2g}$ (B) $\frac{2\omega^2}{5g}$
 (C) $\frac{5\omega^2}{2g}$ (D) $\frac{2\omega^2}{25g}$

2. [Online September 2020]

A capillary tube made of glass of radius 0.15 mm is dipped vertically in a beaker filled with methylene iodide (surface tension = 0.05 Nm^{-1} , density = 667 kgm^{-3}) which rises to height h in the tube. It is observed that the two tangents drawn from liquid-glass interfaces (from opp. Sides of the capillary) make an angle of 60° with one another. Then h is close to ($g = 10 \text{ ms}^{-2}$)

- (A) 0.137 m (B) 0.172 m
 (C) 0.087 m (D) 0.049 m

3. [Online September 2020]

Pressure inside two soap bubbles are 1.01 and 1.02 atmosphere, respectively. The ratio of their volumes is

- (A) 8 : 1 (B) 0.8 : 1
 (C) 2 : 1 (D) 4 : 1

4. [Online September 2020]

A air bubble of radius 1 cm in water has an upward acceleration 9.8 cms^{-2} . The density of water is 1 gcm^{-3} and water offers negligible drag force on the bubble. The mass of the bubble is ($g = 980 \text{ cms}^{-2}$)

- (A) 3.15 g (B) 4.51 g
 (C) 4.15 g (D) 1.52 g

5. [Online September 2020]

A cube of metal is subjected to a hydrostatic pressure of 4 GPa. The percentage change in the length of the side of the cube is close to (Given bulk modulus of metal, $B = 8 \times 10^{10}$ Pa)

- (A) 0.6 (B) 1.67
(C) 5 (D) 20

6. [Online September 2020]

A hollow spherical shell at outer radius R floats just submerged under the water surface. The inner radius of the shell is r . If the specific gravity of the shell material is $\frac{27}{8}$ w.r.t. water, the value of r is

- (A) $\frac{4}{9}R$ (B) $\frac{8}{9}R$
(C) $\frac{1}{3}R$ (D) $\frac{2}{3}R$

7. [Online September 2020]

In an experiment to verify stokes law, a small spherical ball of radius r and density ρ falls under gravity through a distance h in air before entering a tank of water. If the terminal velocity of the ball inside water is same as its velocity just before entering the water surface, then the value of h is proportional to (ignore viscosity of air)

- (A) r (B) r^4
(C) r^3 (D) r^2

8. [Online September 2020]

A fluid is flowing through a horizontal pipe of varying cross-section, with speed v ms^{-1} at a point where the pressure is P Pascal. P at another point where pressure is $\frac{P}{2}$ Pascal its speed is V ms^{-1} . If the density of the fluid is ρ kgm^{-3} and the flow is streamline, then V is equal to

- (A) $\sqrt{\frac{P}{2\rho} + v^2}$ (B) $\sqrt{\frac{P}{\rho} + v^2}$
(C) $\sqrt{\frac{2P}{\rho} + v^2}$ (D) $\sqrt{\frac{P}{\rho} + v}$

9. [Online September 2020]

When a long glass capillary tube of radius 0.015 cm is dipped in a liquid, the liquid rises to a height of 15 cm within it. If the contact angle between the liquid and glass to close to 0° , the surface tension of the liquid, in millinewton per metre, is $[\rho_{\text{liquid}} = 900 \text{ kgm}^{-3}, g = 10 \text{ ms}^{-2}]$ (Give answer in closest integer)

10. [Online January 2020]

An ideal fluid flows (laminar flow) through a pipe of non-uniform diameter. The maximum and minimum diameters of the pipes are 6.4 cm and 4.8 cm, respectively. The ratio of the minimum and the maximum velocities of fluid in this pipe is

- (A) $\frac{\sqrt{3}}{2}$ (B) $\frac{3}{4}$
(C) $\frac{81}{256}$ (D) $\frac{9}{16}$

11. [Online January 2020]

Consider a solid sphere of radius R and mass density $\rho(r) = \rho_0 \left(1 - \frac{r^2}{R^2}\right)$, $0 < r \leq R$. The minimum density of a liquid in which it will float is

- (A) $\frac{\rho_0}{5}$ (B) $\frac{\rho_0}{3}$
(C) $\frac{2\rho_0}{3}$ (D) $\frac{2\rho_0}{5}$

12. [Online January 2020]

A leak proof cylinder of length 1 m, made of a metal which has very low coefficient of expansion is floating vertically in water at 0°C such that its height above the water surface is 20 cm. When the temperature of water is increased to 4°C , the height of the cylinder above the water surface becomes 21 cm. The density of water at $T = 4^\circ\text{C}$, relative to the density at $T = 0^\circ\text{C}$ is close to

- (A) 1.01 (B) 1.04
(C) 1.03 (D) 1.26

13. [Online January 2020]

Two liquids of densities ρ_1 and ρ_2 ($\rho_2 = 2\rho_1$) are filled up behind a square wall of side 10 m as shown in Figure. Each liquid has a height of 5 m. The ratio of the forces due to these liquids exerted on upper part MN to that at the lower part NO is (Assume that the liquids are not mixing)

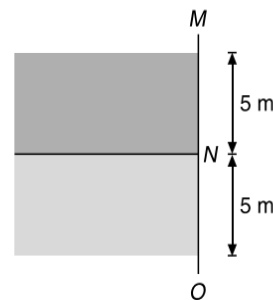

- (A) $\frac{1}{4}$ (B) $\frac{2}{3}$
(C) $\frac{1}{3}$ (D) $\frac{1}{2}$

14. [Online January 2020]

Water flows in a horizontal tube (see figure). The pressure of water changes by 700 Nm^{-2} between A and B where the area of cross section are 40 cm^2 and 20 cm^2 , respectively. Find the rate of flow of water through the tube. (density of water = 1000 kgm^{-3})

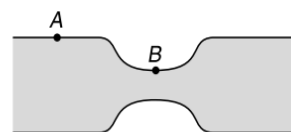

- (A) $1810 \text{ cm}^3\text{s}^{-1}$
(B) $3020 \text{ cm}^3\text{s}^{-1}$
(C) $2720 \text{ cm}^3\text{s}^{-1}$
(D) $2420 \text{ cm}^3\text{s}^{-1}$

1.172 JEE Advanced Physics: Waves and Thermodynamics
15. [Online January 2020]

A small spherical droplet of density d is floating exactly half immersed in a liquid of density ρ and surface tension T . The radius of the droplet is (take note that the surface tension applies an upward force on the droplet)

$$(A) r = \sqrt{\frac{2T}{3(d+\rho)g}} \quad (B) r = \sqrt{\frac{3T}{(2d-\rho)g}}$$

$$(C) r = \sqrt{\frac{T}{(d-\rho)g}} \quad (D) r = \sqrt{\frac{T}{(d+\rho)g}}$$

16. [Online January 2020]

Two steel wires having same length are suspended from a ceiling under the same load. If the ratio of their energy stored per unit volume is 1:4, the ratio of their diameters is

$$(A) 1:\sqrt{2} \quad (B) 1:2$$

$$(C) 2:1 \quad (D) \sqrt{2}:1$$

17. [Online January 2020]

A body of mass $m = 10$ kg is attached to one end of a wire of length 0.3 m. The maximum angular speed (in rads^{-1}) with which it can be rotated about its other end in space station is (Breaking stress of wire = $4.8 \times 10^7 \text{ Nm}^{-2}$ and area of cross-section of the wire = 10^{-2} cm^2) is

18. [Online April 2019]

Water from a pipe is coming at a rate of 100 liters per minute. If the radius of the pipe is 5 cm, the Reynolds number for the flow is of the order of (density of water 1000 kgm^{-3} , coefficient of viscosity of water 1 mPas)

$$(A) 10^2 \quad (B) 10^4$$

$$(C) 10^3 \quad (D) 10^6$$

19. [Online April 2019]

If M is the mass of water that rises in a capillary tube of radius r , then mass of water which will rise in a capillary tube of radius $2r$ is

$$(A) 2M \quad (B) M$$

$$(C) 4M \quad (D) \frac{M}{2}$$

20. [Online April 2019]

A wooden block floating in a bucket of water has $\frac{4}{5}$ of its volume submerged. When certain amount of an oil is poured into the bucket, it is found that the block is just under the oil surface with half of its volume under water and half in oil. The density of oil relative to that of water is

$$(A) 0.5 \quad (B) 0.8$$

$$(C) 0.7 \quad (D) 0.6$$

21. [Online April 2019]

The ratio of surface tensions of mercury and water is given to be 7.5 while the ratio of their densities is 13.6. Their contact angles, with glass, are close to 135° and 0° , respectively. It is observed that mercury gets depressed by an amount h in a capillary tube of radius r_1 , while water rises by the same amount h in a capillary tube of radius r_2 . The ratio, $\left(\frac{r_1}{r_2}\right)$, is then close to

$$(A) \frac{4}{5} \quad (B) \frac{2}{3}$$

$$(C) \frac{3}{5} \quad (D) \frac{2}{5}$$

22. [Online April 2019]

A cubical block of side 0.5 m floats on water with 30% of its volume under water. What is the maximum weight that can be put on the block without fully submerging it under water? [Take, density of water = 10^3 kgm^{-3}]

$$(A) 30.1 \text{ kg} \quad (B) 46.3 \text{ kg}$$

$$(C) 87.5 \text{ kg} \quad (D) 65.4 \text{ kg}$$

23. [Online April 2019]

Water from a tap emerges vertically downwards with an initial speed of 1.0 ms^{-1} . The cross-sectional area of the tap is 10^{-4} m^2 . Assume that the pressure is constant throughout the stream of water and that the flow is streamlined. The cross-sectional area of stream, 0.15 m below the tap would be (Take $g = 10 \text{ ms}^{-2}$)

$$(A) 1 \times 10^{-5} \text{ m}^2 \quad (B) 5 \times 10^{-5} \text{ m}^2$$

$$(C) 5 \times 10^{-4} \text{ m}^2 \quad (D) 2 \times 10^{-5} \text{ m}^2$$

24. [Online April 2019]

A submarine experiences a pressure of $5.05 \times 10^6 \text{ Pa}$ at a depth of d_1 in a sea. When it goes further to a depth of d_2 , it experiences a pressure of $8.08 \times 10^6 \text{ Pa}$. Then $d_2 - d_1$ is approximately (density of water = 10^3 kgm^{-3} and acceleration due to gravity = 10 ms^{-2})

$$(A) 600 \text{ m} \quad (B) 500 \text{ m}$$

$$(C) 300 \text{ m} \quad (D) 400 \text{ m}$$

25. [Online April 2019]

A solid sphere, of radius R acquires a terminal velocity v_1 when falling (due to gravity) through a viscous fluid having a coefficient of viscosity η . The sphere is broken into 27 identical solid spheres. If each of these spheres acquires a terminal velocity, v_2 , when falling through the same fluid, the ratio $\left(\frac{v_1}{v_2}\right)$ equals

$$(A) \frac{1}{27} \quad (B) 9$$

$$(C) \frac{1}{9} \quad (D) 27$$

26. [Online January 2019]

The top of a water tank is open to air and its water level is maintained. It is giving out 0.74 m^3 water per minute through a circular opening of 2 cm radius in its wall. The depth of the centre of the opening from the level of water in the tank is close to

$$(A) 9.6 \text{ m} \quad (B) 2.9 \text{ m}$$

$$(C) 4.8 \text{ m} \quad (D) 6.0 \text{ m}$$

27. [Online January 2019]

Water flows into a large tank with flat bottom at the rate of $10^{-4} \text{ m}^3 \text{ s}^{-1}$. Water is also leaking out of a hole of area 1 cm^2

at its bottom. If the height of the water in the tank remains steady, then this height is

- (A) 5.1 cm (B) 1.7 cm
(C) 2.9 cm (D) 4 cm

28. [Online January 2019]

A liquid of density ρ is coming out of a hose pipe of radius a with horizontal speed v and hits a mesh. 50% of the liquid passes through the mesh unaffected. 25% loses all of its momentum and 25% comes back with the same speed. The resultant pressure on the mesh will be

- (A) $\frac{3}{4}\rho v^2$ (B) $\frac{1}{4}\rho v^2$
(C) $\frac{1}{2}\rho v^2$ (D) ρv^2

29. [Online January 2019]

A load of mass M kg is suspended from a steel wire of length 2 m and radius 1.0 mm in Searle's apparatus experiment. The increase in length produced in the wire is 4.0 mm. Now the load is fully immersed in a liquid of relative density 2. The relative density of the material of the load is 8. The new value of increase in length of the steel wire is

- (A) 4.0 mm (B) zero
(C) 5.0 mm (D) 3.0 mm

30. [Online January 2019]

A soap bubble, blown by a mechanical pump at the mouth of a tube, increases in volume, with time, at a constant rate. The graph that correctly depicts the time dependence of pressure inside the bubble is given by

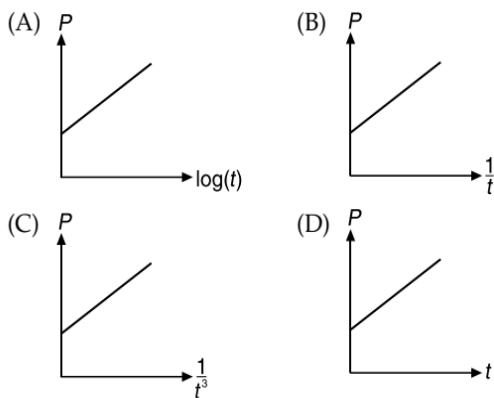

31. [Online January 2019]

A long cylindrical vessel is half filled with a liquid. When the vessel is rotated about its own vertical axis, the liquid rises up near the wall. If the radius of vessel is 5 cm and its rotational speed is 2 rotations per second, then the difference in the heights between the centre and the sides, in cm, will be

- (A) 1.2 (B) 0.1
(C) 0.4 (D) 2.0

32. [2018]

A solid sphere of radius r made of a soft material of bulk modulus K is surrounded by a liquid in a cylindrical container. A massless piston of area a floats on the surface of the liquid, covering entire cross section of cylindrical container.

When a mass m is placed on the surface of the piston to compress the liquid, the fractional decrement in the radius of the sphere, $\left(\frac{dr}{r}\right)$, is

- (A) $\frac{Ka}{mg}$ (B) $\frac{Ka}{3mg}$
(C) $\frac{mg}{3Ka}$ (D) $\frac{mg}{Ka}$

33. [Online 2018]

When an air bubble of radius r rises from the bottom to the surface of a lake, its radius becomes $\frac{5r}{4}$. Taking the atmospheric pressure to be equal to 10 m height of water column, the depth of the lake would approximately be (ignore the surface tension and the effect of temperature)

- (A) 11.2 m (B) 10.5 m
(C) 9.5 m (D) 8.7 m

34. [Online 2018]

As shown in the figure, forces of 10^5 N each are applied in opposite directions, on the upper and lower faces of a cube of side 10 cm, shifting the upper face parallel to itself by 0.5 cm, if the side of another cube of the same material is 20 cm, then under similar conditions as above, the displacement will be



- (A) 0.25 cm (B) 0.37 cm
(C) 1.00 cm (D) 0.75 cm

35. [Online 2018]

A small soap bubble of radius 4 cm is trapped inside another bubble of radius 6 cm without any contact. Let P_2 be the pressure inside the inner bubble and P_0 , the pressure outside the outer bubble. Radius of another bubble with pressure difference $P_2 - P_0$ between its inside and outside would be

- (A) 12 cm (B) 4.8 cm
(C) 2.4 cm (D) 6 cm

36. [2017]

A man grows into a giant such that his linear dimensions increase by a factor of 9. Assuming that his density remains same, the stress in the leg will change by a factor of

- (A) 9 (B) $\frac{1}{9}$
(C) 81 (D) $\frac{1}{81}$

37. [Online 2017]

Two tubes of radii r_1 and r_2 and lengths l_1 and l_2 , respectively, are connected in series and a liquid flows through each of them in streamline conditions. P_1 and P_2 are pressure differences across the two tubes. If P_2 is $4P_1$ and l_2 is $\frac{l_1}{4}$, then the radius r_2 will be equal to

1.174 JEE Advanced Physics: Waves and Thermodynamics

- (A) $2r_1$ (B) $\frac{r_1}{2}$
 (C) $4r_1$ (D) r_1

38. [Online 2016]

A uniformly tapering conical wire is made from a material of Young's modulus Y and has a normal, unextended length L . The radii, at the upper and lower ends of this conical wire, have values R and $3R$, respectively. The upper end of the wire is fixed to a rigid support and a mass M is suspended from its lower end. The equilibrium extended length, of this wire, would equal

- (A) $L\left(1 + \frac{2Mg}{9\pi YR^2}\right)$ (B) $L\left(1 + \frac{1Mg}{9\pi YR^2}\right)$
 (C) $L\left(1 + \frac{1Mg}{3\pi YR^2}\right)$ (D) $L\left(1 + \frac{2Mg}{3\pi YR^2}\right)$

39. [Online 2016]

Consider a water jar of radius R that has water filled up to height H and is kept on a stand of height h (see figure). Through a hole of radius r ($r \ll R$) at its bottom, the water leaks out and the stream of water coming down towards the ground has a shape like a funnel as shown in the figure. If the radius of the cross-section of water stream when it hits the ground is x . Then

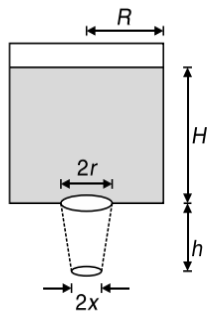

- (A) $x = r\left(\frac{H}{H+h}\right)^{\frac{1}{4}}$ (B) $x = r\left(\frac{H}{H+h}\right)$
 (C) $x = r\left(\frac{H}{H+h}\right)^2$ (D) $x = r\left(\frac{H}{H+h}\right)^{\frac{1}{2}}$

40. [Online 2016]

Which of the following option correctly describes the variation of the speed v and acceleration a of a point mass falling vertically in a viscous medium that applies a force $F = -kv$, where k is a constant, on the body? (Graphs are schematic and not drawn to scale)

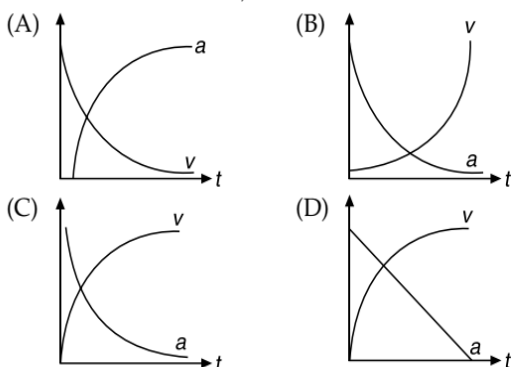

41. [Online 2016]

A bottle has an opening of radius a and length b . A cork of length b and radius $(a + \Delta a)$ where ($\Delta a \ll a$) is compressed to fit into the opening completely (see figure). If the bulk modulus of cork is B and frictional coefficient between the bottle and cork is μ then the force needed to push the cork into the bottle is



- (A) $(\pi\mu Bb)a$ (B) $(2\pi\mu Bb)\Delta a$
 (C) $(\pi\mu Bb)\Delta a$ (D) $(4\pi\mu Bb)\Delta a$

42. [Online 2015]

If it takes 5 minutes to fill a 15 litre bucket from a water tap of diameter $\frac{2}{\sqrt{\pi}}$ cm then the Reynolds number for the flow is (density of water is 10^3 kg m^{-3} and viscosity of water is 10^{-3} Pas) close to

- (A) 5500 (B) 11000
 (C) 550 (D) 1100

43. [Online 2015]

If two glass plates have water between them and are separated by very small distance (see figure), it is very difficult to pull them apart. It is because the water in between forms cylindrical surface on the side that gives rise to lower pressure in the water in comparison to atmosphere. If the radius of the cylindrical surface is R and surface tension of water is T then the pressure in water between the plates is lower by

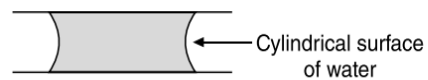

- (A) $\frac{T}{4R}$ (B) $\frac{T}{2R}$
 (C) $\frac{4T}{R}$ (D) $\frac{2T}{R}$

44. [2014]

An open glass tube is immersed in mercury in such a way that a length of 8 cm extends above the mercury level. The open end of the tube is then closed and sealed and the tube is raised vertically up by additional 46 cm. What will be length of the air column above mercury in the tube now? (Atmospheric pressure = 76 cm of Hg)

- (A) 16 cm (B) 22 cm
 (C) 38 cm (D) 6 cm

45. [2014]

There is a circular tube in a vertical plane. Two liquids which do not mix and of densities d_1 and d_2 are filled in the tube.

Each liquid subtends 90° angle at centre. Radius joining their interface makes an angle α with vertical. Ratio $\frac{d_1}{d_2}$ is

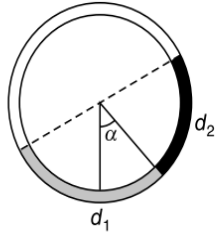

- (A) $\frac{1 + \sin \alpha}{1 - \sin \alpha}$ (B) $\frac{1 + \cos \alpha}{1 - \cos \alpha}$
 (C) $\frac{1 + \tan \alpha}{1 - \tan \alpha}$ (D) $\frac{1 + \sin \alpha}{1 - \cos \alpha}$

46. [2014]

On heating water, bubbles being formed at the bottom of the vessel detach and rise. Take the bubbles to be spheres of radius R and making a circular contact of radius r with the bottom of the vessel. If $x \ll R$ and the surface tension of water is T , value of r just before bubbles detach is (density of water is ρ_w)

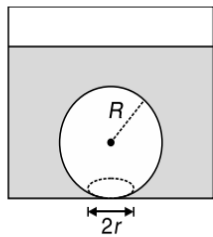

- (A) $R^2 \sqrt{\frac{2\rho_w g}{3T}}$ (B) $R^2 \sqrt{\frac{\rho_w g}{6T}}$
 (C) $R^2 \sqrt{\frac{\rho_w g}{T}}$ (D) $R^2 \sqrt{\frac{3\rho_w g}{T}}$

47. [2013]

A uniform cylinder of length L and mass M having cross-sectional area A is suspended, with its length vertical, from a fixed point by a massless spring, such that it is half submerged in a liquid of density σ at equilibrium position. The extension x_0 of the spring when it is in equilibrium is

- (A) $\frac{Mg}{k}$ (B) $\frac{Mg}{k} \left(1 - \frac{LA\sigma}{M}\right)$
 (C) $\frac{Mg}{k} \left(1 - \frac{LA\sigma}{2M}\right)$ (D) $\frac{Mg}{k} \left(1 + \frac{LA\sigma}{M}\right)$

48. [2012]

A thin liquid film formed between a U-shaped wire and a light slider supports a weight of 1.5×10^{-2} N (see figure). The length of the slider is 30 cm and its weight negligible. The surface tension of the liquid film is

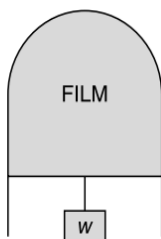

- (A) 0.1 Nm^{-1} (B) 0.05 Nm^{-1}
 (C) 0.025 Nm^{-1} (D) 0.0125 Nm^{-1}

49. [2011]

Water is flowing continuously from a tap having an internal diameter 8×10^{-3} m. The water velocity as it leaves the tap is 0.4 ms^{-1} . The diameter of the water stream at a distance 2×10^{-1} m below the tap is close to

- (A) 5.0×10^{-3} m (B) 7.5×10^{-3} m
 (C) 9.6×10^{-3} m (D) 3.6×10^{-3} m

50. [2011]

Work done in increasing the size of a soap bubble from a radius of 3 cm to 5 cm is nearly (Surface tension of soap solution = 0.03 Nm^{-1})

- (A) $4\pi \text{ mJ}$ (B) $0.2\pi \text{ mJ}$
 (C) $2\pi \text{ mJ}$ (D) $0.4\pi \text{ mJ}$

51. [2010]

The potential energy function for the force between two atoms in a diatomic molecule is approximately given by $U(x) = \frac{a}{x^{12}} - \frac{b}{x^6}$, where a and b are constants and x is the distance between the atoms. If the dissociation energy of the molecule is $D = [U(x = \infty) - U_{\text{at equilibrium}}]$, D is

- (A) $\frac{b^2}{6a}$ (B) $\frac{b^2}{2a}$
 (C) $\frac{b^2}{12a}$ (D) $\frac{b^2}{4a}$

52. [2010]

A ball is made of a material of density ρ where $\rho_{\text{oil}} < \rho < \rho_{\text{water}}$ with ρ_{oil} and ρ_{water} representing the densities of oil and water, respectively. The oil and water are immiscible. If the above ball is in equilibrium in a mixture of this oil and water, which of the following pictures represents its equilibrium position?

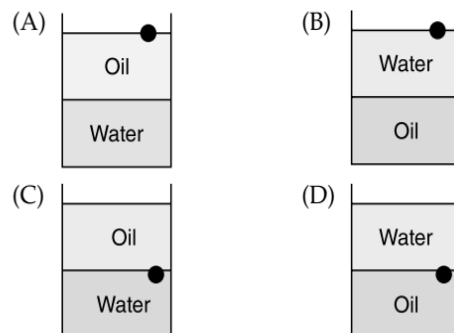

53. [2009]

Two wires are made of the same material and have the same volume. However, wire 1 has cross-sectional area A and wire 2 has cross-sectional area $3A$. If the length of wire 1 increases by Δx on applying force F , how much force is needed to stretch wire 2 by the same amount?

- (A) F (B) $4F$
 (C) $6F$ (D) $9F$

ARCHIVE: JEE ADVANCED
Single Correct Choice Type Problems

(In this section each question has four choices (A), (B), (C) and (D), out of which ONLY ONE is correct)

1. [JEE (Advanced) 2020]

An open-ended U-tube of uniform cross-sectional area contains water (density 10^3 kgm^{-3}). Initially the water level stands at 0.29 m from the bottom in each arm. Kerosene oil (a water-immiscible liquid) of density 800 kgm^{-3} is added to the left arm until its length is 0.1 m, as shown in the schematic figure below. The ratio $\left(\frac{h_1}{h_2}\right)$ of the heights of the liquid in the two arms is

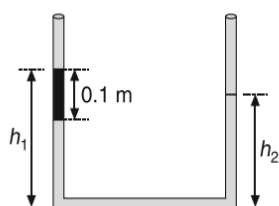

- (A) $\frac{15}{14}$ (B) $\frac{35}{33}$
 (C) $\frac{7}{6}$ (D) $\frac{5}{4}$

2. [JEE (Advanced) 2014]

A glass capillary tube is of the shape of truncated cone with an apex angle α so that its two ends have cross-sections of different radii. When dipped in water vertically, water rises in it to a height h , where the radius of its cross-section is b . If the surface tension of water is S , its density is ρ and its contact angle with glass is θ , the value of h will be (g is the acceleration due to gravity)

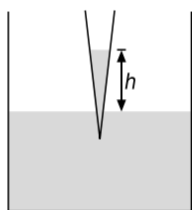

- (A) $\frac{2S}{b\rho g} \cos(\theta - \alpha)$ (B) $\frac{2S}{b\rho g} \cos(\theta + \alpha)$
 (C) $\frac{2S}{b\rho g} \cos\left(\theta - \frac{\alpha}{2}\right)$ (D) $\frac{2S}{b\rho g} \cos\left(\theta + \frac{\alpha}{2}\right)$

3. [JEE (Advanced) 2013]

One end of a horizontal thick copper wire of length $2L$ and radius $2R$ is welded to an end of another horizontal thin copper wire of length L and radius R . When the arrangement is stretched by applying forces at two ends, the ratio of the elongation in the thin wire to that in the thick wire is

- (A) 0.25 (B) 0.50
 (C) 2.00 (D) 4.00

4. [IIT-JEE 2012]

A thin uniform cylindrical shell, closed at both ends, is partially filled with water. It is floating vertically in water in half-submerged state. If ρ_c is the relative density of the material of the shell with respect to water, then the correct statement is that the shell is

- (A) more than half-filled if ρ_c is less than 0.5
 (B) more than half-filled if ρ_c is more than 1.0
 (C) half-filled if ρ_c is more than 0.5
 (D) less than half-filled if ρ_c is less than 0.5

5. [IIT-JEE 2008]

A glass tube of uniform internal radius (r) has a valve separating the two identical ends. Initially, the valve is in a tightly closed position. End 1 has a hemispherical soap bubble of radius r . End 2 has sub-hemispherical soap bubble as shown in figure. Just after opening the valve.

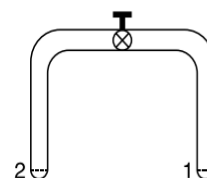

- (A) air from end 1 flows towards end 2. No change in the volume of the soap bubbles
 (B) air from end 1 flows towards end 2. Volume of the soap bubble at end 1 decreases
 (C) no change occurs
 (D) air from end 2 flows towards end 1. Volume of the soap bubble at end 1 increases

6. [IIT-JEE 2007]

Water is filled up to a height h in a beaker of radius R as shown in the figure. The density of water is ρ , the surface tension of water is T and the atmospheric pressure is p_0 . Consider a vertical section $ABCD$ of the water column through a diameter of the beaker. The force on water on one side of this section by water on the other side of this section has magnitude

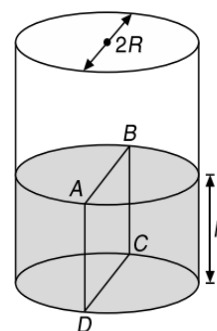

- (A) $|2p_0Rh + \pi R^2 \rho gh - 2RT|$
 (B) $|2p_0Rh + R\rho gh^2 - 2RT|$
 (C) $|p_0\pi R^2 + R\rho gh^2 - 2RT|$
 (D) $|p_0\pi R^2 + R\rho gh^2 + 2RT|$

7. [IIT-JEE 2005]

Water is filled in a cylindrical container to a height of 3 m. The ratio of the cross-sectional area of the orifice and the beaker is 0.1. The square of the speed of the liquid coming out from the orifice is ($g = 10 \text{ ms}^{-2}$)

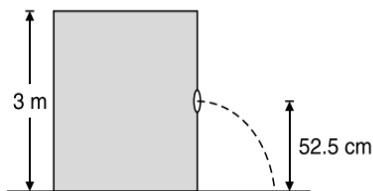

- (A) $50 \text{ m}^2\text{s}^{-2}$ (B) $50.5 \text{ m}^2\text{s}^{-2}$
 (C) $51 \text{ m}^2\text{s}^{-2}$ (D) $52 \text{ m}^2\text{s}^{-2}$

8. [IIT-JEE 2005]

The pressure of a medium is changed from $1.01 \times 10^5 \text{ Pa}$ to $1.165 \times 10^5 \text{ Pa}$ and change in volume is 10% keeping temperature constant. The bulk modulus of the medium is

- (A) $204.8 \times 10^5 \text{ Pa}$ (B) $102.4 \times 10^5 \text{ Pa}$
 (C) $51.2 \times 10^5 \text{ Pa}$ (D) $1.55 \times 10^5 \text{ Pa}$

9. [IIT-JEE 2003]

The graph shows the extension (Δl) of a wire of length $l \text{ m}$ suspended from the top of a roof at one end and with a load W connected to the other end. If the cross-sectional area of the wire is 10^{-6} m^2 , calculate the Young's modulus of the material of the wire

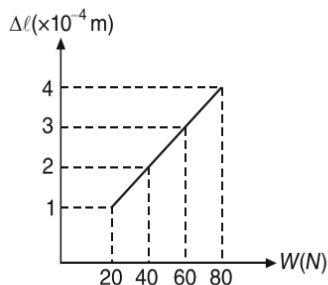

- (A) $2 \times 10^{11} \text{ Nm}^{-2}$ (B) $2 \times 10^{-11} \text{ Nm}^{-2}$
 (C) $3 \times 10^{12} \text{ Nm}^{-2}$ (D) $2 \times 10^{13} \text{ Nm}^{-2}$

10. [IIT-JEE 2002]

A wooden block, with a coin placed on its top, floats in water as shown in Figure.

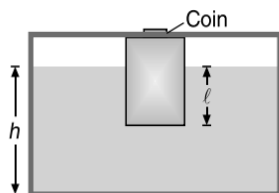

The distance l and h are shown there. After sometime the coin falls into the water. Then

- (A) l decreases and h increases
 (B) l increases and h decreases
 (C) both l and h increase
 (D) both l and h decrease

11. [IIT-JEE 2001]

A hemispherical portion of radius R is removed from the bottom of a cylinder of radius R . The volume of the remaining cylinder is V and mass M . It is suspended by a string in a liquid of density ρ , where it stays vertical. The upper surface of the cylinder is at a depth h below the liquid surface. The force on the bottom of the cylinder by the liquid is

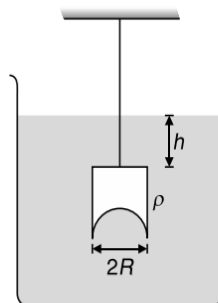

- (A) Mg (B) $Mg - V\rho g$
 (C) $Mg + \pi R^2 h \rho g$ (D) $\rho g(V + \pi R^2 h)$

12. [IIT-JEE 2000]

A large open tank has two holes in the wall. One is a square hole of side L at a depth y from the top and the other is a circular hole of radius R at a depth $4y$ from the top. When the tank is completely filled with water, the quantities of water flowing out per second from both holes are the same. Then, R is equal to

- (A) $\frac{L}{\sqrt{2\pi}}$ (B) $2\pi L$
 (C) L (D) $\frac{L}{2\pi}$

13. [IIT-JEE 1999]

A closed compartment containing gas is moving with some acceleration in horizontal direction. Neglect effect of gravity. Then the pressure in the compartment is

- (A) same everywhere
 (B) lower in front side
 (C) lower in rear side
 (D) lower in upper side

14. [IIT-JEE 1998]

Water from a tap emerges vertically downwards with an initial speed of 1 ms^{-1} . The cross-sectional area of tap is 10^{-4} m^2 . Assume that the pressure is constant throughout and that the flow is steady, the cross-sectional area of stream 0.15 m below the tap is

- (A) $5 \times 10^{-4} \text{ m}^2$ (B) $1 \times 10^{-4} \text{ m}^2$
 (C) $5 \times 10^{-5} \text{ m}^2$ (D) $2 \times 10^{-5} \text{ m}^2$

15. [IIT-JEE 1995]

A homogeneous solid cylinder of length L ($L < \frac{H}{2}$), cross-sectional area $\frac{A}{5}$ is immersed such that it floats with its axis vertical at the liquid-liquid interface with length $\frac{L}{4}$ in the

1.178 JEE Advanced Physics: Waves and Thermodynamics

denser liquid as shown in the figure. The lower density liquid is open to atmosphere having pressure P_0 . Then, density D of solid is given by

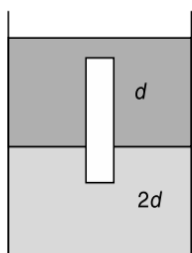

- (A) $\frac{5}{4}d$ (B) $\frac{4}{5}d$
 (C) $4d$ (D) $\frac{d}{5}$

16. [IIT-JEE 1988]

A vessel contains oil (density = 0.8 gcm^{-3}) over mercury (density = 13.6 gcm^{-3}). A homogeneous sphere floats with half its volume immersed in mercury and the other half in oil. The density of the material of the sphere in gcm^{-3} is

- (A) 3.3 (B) 6.4
 (C) 7.2 (D) 12.8

17. [IIT-JEE 1983]

A U-tube of uniform cross-section is partially filled with a liquid I. Another liquid II which does not mix with liquid I is poured into one side. It is found that the liquid levels of the two sides of the tube are the same, while the level of liquid I has risen by 2 cm. If the specific gravity of liquid I is 1.1, the specific gravity of liquid II must be

- (A) 1.12 (B) 1.1
 (C) 1.05 (D) 1.0

18. [IIT-JEE 1982]

A body floats in a liquid contained in a beaker. The whole system as shown in figure falls freely under gravity. The upthrust on the body is

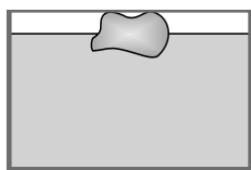

- (A) ZERO
 (B) equal to the weight of liquid displaced
 (C) equal to the weight of the body in air
 (D) equal to the weight of the immersed portion of the body

19. [IIT-JEE 1981]

The following four wires are made of the same material. Which of these will have the largest extension when the same tension is applied?

- (A) Length = 50 cm, diameter = 0.5 mm
 (B) Length = 100 cm, diameter = 1 mm
 (C) Length = 200 cm, diameter = 2 mm
 (D) Length = 300 cm, diameter = 3 mm

20. [IIT-JEE 1981]

A vessel containing water is given a constant acceleration a towards the right along a straight horizontal path. Which of the following diagrams represents the surface of the liquid?

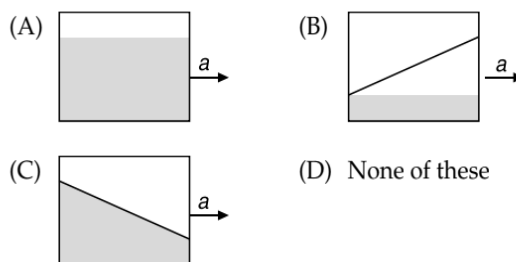

Multiple Correct Choice Type Problems

(In this section each question has four choices (A), (B), (C) and (D), out of which ONE OR MORE is/are correct)

1. [JEE (Advanced) 2019]

A cylindrical capillary tube of 0.2 mm radius is made by joining two capillaries T_1 and T_2 of different materials having water contact angles of 0° and 60° , respectively. The capillary tube is dipped vertically in water in two different configurations, Case I and II as shown in figure. Which of the following option(s) is (are) correct? [Surface tension of water is 0.075 Nm^{-1} , density of water is 1000 kgm^{-3} , take $g = 10 \text{ ms}^{-2}$]

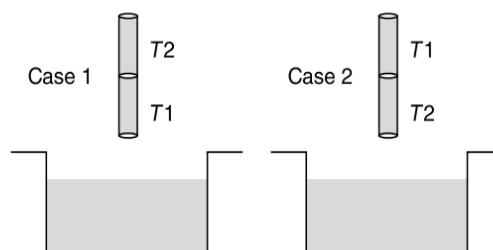

- (A) For case II, if the capillary joint is 5 cm above the water surface, the height of water column raised in the tube will be 3.75 cm. (Neglect the weight of the water in the meniscus)
 (B) For case I, if the joint is kept at 8 cm above the water surface, the height of water column in the tube will be 7.5 cm. (Neglect the weight of the water in the meniscus)
 (C) For case I, if the capillary joint is 5 cm above the water surface, the height of water column raised in the tube will be more than 8.75 cm. (Neglect the weight of the water in the meniscus)
 (D) The correction in the height of water column raised in the tube, due to weight of water contained in the meniscus, will be different for both cases.

2. [JEE (Advanced) 2015]

Two spheres P and Q for equal radii have densities ρ_1 and ρ_2 , respectively. The spheres are connected by a massless string and placed in liquids L_1 and L_2 of densities σ_1 and σ_2 and viscosities η_1 and η_2 , respectively. They float in equilibrium with the sphere P in L_1 and sphere Q in L_2 and the string being taut (see figure). If sphere P alone in L_2 has

terminal velocity \bar{v}_P and Q alone in L_1 has terminal velocity \bar{v}_Q , then

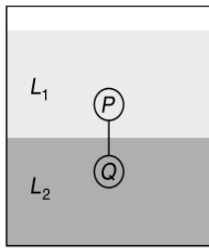

- (A) $\frac{|\bar{v}_P|}{|\bar{v}_Q|} = \frac{\eta_1}{\eta_2}$
- (B) $\frac{|\bar{v}_P|}{|\bar{v}_Q|} = \frac{\eta_2}{\eta_1}$
- (C) $\bar{v}_P \cdot \bar{v}_Q > 0$
- (D) $\bar{v}_P \cdot \bar{v}_Q < 0$

3. [JEE (Advanced) 2015]

In plotting stress versus strain curves for two materials P and Q , a student by mistake puts strain on the Y-axis and stress on the X-axis as shown in the figure. Then the correct statements is/are

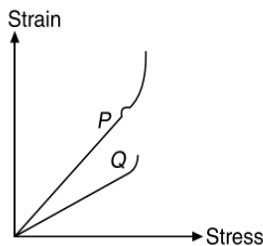

- (A) P has more tensile strength than Q
- (B) P is more ductile than Q
- (C) P is more brittle than Q
- (D) The Young's modulus of P is more than that of Q

4. [JEE (Advanced) 2013]

A solid sphere of radius R and density ρ is attached to one end of a massless spring of force constant k . The other end of the spring is connected to another solid sphere of radius R and density 3ρ . The complete arrangement is placed in a liquid of density 2ρ and is allowed to reach equilibrium. The correct statement(s) is (are)

- (A) the net elongation of the spring is $\frac{4\pi R^3 \rho g}{3k}$
- (B) the net elongation of the spring is $\frac{8\pi R^3 \rho g}{3k}$
- (C) the light sphere is partially submerged
- (D) the light sphere is completely submerged

5. [JEE (Advanced) 2011]

Two solid spheres A and B of equal volumes but of different densities d_A and d_B are connected by a string. They are fully immersed in a fluid of density d_f . They get arranged into an equilibrium state as shown in the figure with a tension in the string. The arrangement is possible only if

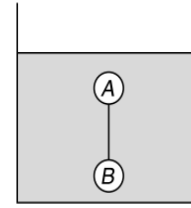

- (A) $d_A < d_f$
- (B) $d_B > d_f$
- (C) $d_A > d_f$
- (D) $d_A + d_B = 2d_f$

6. [IIT-JEE 1985]

The spring balance A leads 2 kg with a mass m suspended from it. A balance B reads 5 kg when a beaker with liquid is put on the pan of the balance. The two balances are now so arranged that the hanging mass is inside the liquid in the beaker as shown in the figure. In this situation.

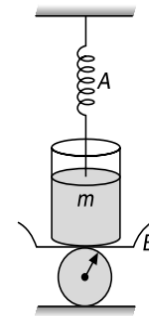

- (A) the balance A will read more than 2 kg
- (B) the balance B will read more than 5 kg
- (C) the balance A will read less than 2 kg
- (D) the balances A and B will read 2 kg and 5 kg respectively

Reasoning Based Questions

This section contains Reasoning type questions, each having four choices (A), (B), (C) and (D) out of which ONLY ONE is correct. Each question contains STATEMENT 1 and STATEMENT 2. You have to mark your answer as

- Bubble (A)** If both statements are TRUE and STATEMENT 2 is the correct explanation of STATEMENT 1.
- Bubble (B)** If both statements are TRUE but STATEMENT 2 is not the correct explanation of STATEMENT 1.
- Bubble (C)** If STATEMENT 1 is TRUE and STATEMENT 2 is FALSE.
- Bubble (D)** If STATEMENT 1 is FALSE but STATEMENT 2 is TRUE.

1. [IIT-JEE 2008]

Statement-1: The stream of water flowing at high speed from a garden hose pipe tends to spread like a fountain when held vertically up, but tends to narrow down when held vertically down.

Statement-2: In any steady flow of an incompressible fluid, the volume flow rate of the fluid remains constant.

Matrix Match/Column Match Type Questions

Each question in this section contains statements given in two columns, which have to be matched. The statements in **COLUMN-I** are labelled A, B, C and D, while the statements in **COLUMN-II** are labelled p, q, r, s (and t). Any given statement in **COLUMN-I** can have correct matching with **ONE OR MORE** statement(s) in **COLUMN-II**. The appropriate bubbles corresponding to the answers to these questions have to be darkened as illustrated in the following examples:

If the correct matches are $A \rightarrow p, s$ and t ; $B \rightarrow q$ and r ; $C \rightarrow p$ and q ; and $D \rightarrow s$ and t ; then the correct darkening of bubbles will look like the following:

	p	q	r	s	t
A	<input checked="" type="checkbox"/>	<input type="checkbox"/>	<input type="checkbox"/>	<input checked="" type="checkbox"/>	<input checked="" type="checkbox"/>
B	<input type="checkbox"/>	<input checked="" type="checkbox"/>	<input checked="" type="checkbox"/>	<input type="checkbox"/>	<input type="checkbox"/>
C	<input checked="" type="checkbox"/>	<input checked="" type="checkbox"/>	<input type="checkbox"/>	<input type="checkbox"/>	<input type="checkbox"/>
D	<input type="checkbox"/>	<input type="checkbox"/>	<input type="checkbox"/>	<input checked="" type="checkbox"/>	<input checked="" type="checkbox"/>

1. [JEE (Advanced) 2014]

A person in a lift is holding a water jar, which has a small hole at the lower end of its side. When the lift is at rest, the water jet coming out of the hole hits the floor of the lift at a distance d of 1.2 m from the person. In the following, state of the lift's motion is given in List I and the distance where the water jet hits the floor of the lift is given in List II. Match the statements from List I with those in List II and select the correct answer using the code given below the lists.

COLUMN-I	COLUMN-II
A. Lift is accelerating vertically up	p. $d = 1.2$ m
B. Lift is accelerating vertically down with an acceleration less than the gravitational acceleration.	q. $d > 1.2$ m
C. Lift is moving vertically up with constant speed.	r. $d < 1.2$ m
D. Lift is falling freely.	s. No water leaks out of the jar

Linked Comprehension Type Questions

This section contains Linked Comprehension Type Questions or Paragraph based Questions. Each set consists of a Paragraph followed by questions. Each question has four choices (A), (B), (C) and (D), out of which only one is correct. (For the sake of competitiveness there may be a few questions that may have more than one correct options)

Comprehension 1

A spray gun is shown in the figure where a piston pushes air out of nozzle. A thin tube of uniform cross-section is connected to the nozzle. The other end of the tube is in a small liquid container. As the piston pushes air through the nozzle, the liquid from the container rises into the nozzle and is sprayed out. For the spray

gun shown, the radii of the piston and the nozzle are 20 mm and 1 mm respectively. The upper end of the container is open to the atmosphere.



1. [JEE (Advanced) 2014]

If the piston is pushed at a speed of 5 mms^{-1} , the air comes out of the nozzle with a speed of

- (A) 0.1 ms^{-1} (B) 1 ms^{-1}
(C) 2 ms^{-1} (D) 8 ms^{-1}

2. [JEE (Advanced) 2014]

If the density of air is ρ_a and that of the liquid ρ_l , then for a given piston speed the rate (volume per unit time) at which the liquid is sprayed will be proportional to

- (A) $\sqrt{\frac{\rho_a}{\rho_l}}$ (B) $\sqrt{\rho_a \rho_l}$
(C) $\sqrt{\frac{\rho_l}{\rho_a}}$ (D) ρ_l

Comprehension 2

When liquid medicine of density ρ is to be put in the eye, it is done with the help of a dropper. As the bulb on the top of the dropper is pressed, a drop forms at the opening of the dropper. We wish to estimate the size of the drop. We first assume that the drop formed at the opening is spherical because that requires a minimum increase in its surface energy. To determine the size, we calculate the net vertical force due to the surface tension T when the radius of the drop is R . When this force becomes smaller than the weight of the drop, the drop gets detached from the dropper.

3. [IIT-JEE 2010]

If the radius of the opening of the dropper is r , the vertical force due to the surface tension on the drop of radius R (assuming $r \ll R$) is

- (A) $2\pi rT$ (B) $2\pi RT$
(C) $\frac{2\pi r^2 T}{R}$ (D) $\frac{2\pi R^2 T}{r}$

4. [IIT-JEE 2010]

If $r = 5 \times 10^{-4} \text{ m}$, $\rho = 10^3 \text{ kgm}^{-3}$, $g = 10 \text{ ms}^{-2}$, $T = 0.11 \text{ Nm}^{-1}$, the radius of the drop when it detaches from the dropper is approximately

- (A) $1.4 \times 10^{-3} \text{ m}$
(B) $3.3 \times 10^{-3} \text{ m}$
(C) $2.0 \times 10^{-3} \text{ m}$
(D) $4.1 \times 10^{-3} \text{ m}$

5. [IIT-JEE 2010]

After the drop detaches, its surface energy is

- (A) $1.4 \times 10^{-6} \text{ J}$ (B) $2.7 \times 10^{-6} \text{ J}$
(C) $5.4 \times 10^{-6} \text{ J}$ (D) $8.1 \times 10^{-9} \text{ J}$

Comprehension 3

A wooden cylinder of diameter $4r$, height H and density $\frac{\rho}{3}$ is kept on a hole of diameter $2r$ of a tank, filled with liquid of density ρ as shown in the figure.

6. [IIT-JEE 2006]

Now level of the liquid starts decreasing slowly. When the level of liquid is at a height h_1 above the cylinder the block starts moving up. At what value of h_1 , will the block rise

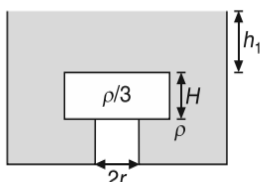

- (A) $\frac{4h}{9}$ (B) $\frac{5h}{9}$
 (C) $\frac{5h}{3}$ (D) remains same

7. [IIT-JEE 2006]

The block in the above question is maintained at the position by external means and the level of liquid is lowered. The height h_2 when this external force reduces to zero is

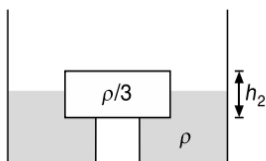

- (A) $\frac{4h}{9}$ (B) $\frac{5h}{9}$
 (C) remains same (D) $\frac{2h}{3}$

8. [IIT-JEE 2006]

If height h_2 of water level is further decreased, then

- (A) cylinder will not move up and remains at its original position
 (B) for $h_2 = \frac{h}{3}$, cylinder again starts moving up
 (C) for $h_2 = \frac{h}{4}$, cylinder again starts moving up
 (D) for $h_2 = \frac{h}{5}$, cylinder again starts moving up

Integer/Numerical Answer Type Questions

In this section, the answer to each question is a numerical value obtained after series of calculations based on the data provided in the question(s).

1. [JEE (Advanced) 2020]

A train with cross-sectional area S_t is moving with speed v_t inside a long tunnel of cross-sectional area S_0 ($S_0 = 4S_t$). Assume that almost all the air (density ρ) in front of the train flows back between its sides and the

walls of the tunnel. Also, the air flow with respect to the train is steady and laminar. Take the ambient pressure and that inside the train to be p_0 . If the pressure in the region between the sides of the train and the tunnel walls is p , then

$$p_0 - p = \frac{7}{2N} \rho v_t^2. \text{ The value of } N \text{ is } \dots\dots$$

2. JEE (Advanced) 2020

When water is filled carefully in a glass, one can fill it to a height h above the rim of the glass due to the surface tension of water. To calculate h just before water starts flowing, model the shape of the water above the rim as a disc of thickness h having semicircular edges, as shown schematically in Figure. When the pressure of water at the bottom of this disc exceeds what can be withstood due to the surface tension, the water surface breaks near the rim and water starts flowing from there. If the density of water, its surface tension and the acceleration due to gravity are 10^3 kg m^{-3} , 0.07 Nm^{-1} and 10 ms^{-2} , respectively, the value of h (in mm) is.....

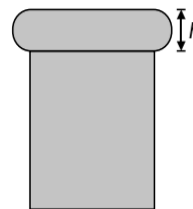

3. JEE (Advanced) 2019

A block of weight 100 N is suspended by copper and steel wires of same cross-sectional area 0.5 cm^2 and, length $\sqrt{3} \text{ m}$ and 1 m , respectively. Their other ends are fixed on a ceiling as shown in figure. The angles subtended by copper and steel wires with ceiling are 30° and 60° , respectively. If elongation in copper wire is (Δl_c) and elongation in steel wire is (Δl_s), then the ratio $\frac{\Delta l_c}{\Delta l_s}$ is

[Young's modulus for copper and steel are $1 \times 10^{11} \text{ Nm}^{-2}$ and $2 \times 10^{11} \text{ Nm}^{-2}$, respectively].

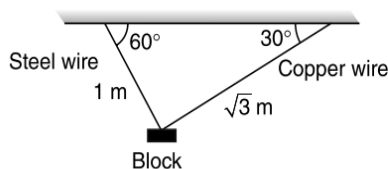

4. [JEE (Advanced) 2017]

A drop of liquid of radius $R = 10^{-2} \text{ m}$ having surface tension $S = \frac{0.1}{4\pi} \text{ Nm}^{-1}$ divides itself into K identical drops. In this process the total change in the surface energy $\Delta U = 10^{-3} \text{ J}$. If $K = 10^\alpha$, then the value of α is

5. [JEE (Advanced) 2016]

Consider two solid spheres P and Q each of density 8 g cm^{-3} and diameters 1 cm and 0.5 cm , respectively. Sphere P is

1.182 JEE Advanced Physics: Waves and Thermodynamics

dropped into a liquid of density 0.8 gcm^{-3} and viscosity $\eta = 3$ poiseulles. Sphere Q is dropped into a liquid of density 1.6 gcm^{-3} and viscosity $\eta = 2$ poiseulles. The ratio of the terminal velocities of P and Q is

6. [JEE (Advanced) 2009]

Two soap bubbles A and B are kept in a closed chamber where the air is maintained at pressure 8 Nm^{-2} . The radii of bubbles A and B are 2 cm , respectively. Surface tension of the soap-water used to make bubbles is 0.04 Nm^{-1} . Find the ratio $\frac{n_B}{n_A}$, where n_A and n_B are the number of moles of air in bubbles A and B , respectively. [Neglect the effect of gravity]

7. [IIT-JEE 2009]

A cylindrical vessel of height 500 mm has an orifice (small hole) at its bottom. The orifice is initially closed and water is filled in it upto height H . Now, the top is completely sealed with a cap and the orifice at the bottom is opened. Some water comes out from the orifice and the water level in the vessel becomes steady with height of water column being 200 mm . Find the fall in height (in mm) of water level due to opening of the orifice. [Take atmospheric pressure $= 1.0 \times 10^5 \text{ Nm}^{-2}$, density of water $= 1000 \text{ kgm}^{-3}$ and $g = 10 \text{ ms}^{-2}$. Neglect any effect of surface tension.]

ANSWER KEYS—TEST YOUR CONCEPTS AND PRACTICE EXERCISES
Test Your Concepts-I
(Based on Young's Modulus, Longitudinal Stress and Strain)

- $\frac{W_1 + \frac{3W}{4}}{S}$
- $T_C = \frac{mg}{4}$ and $T_S = \frac{mg}{2}$
- $\Delta L_B = 4 \text{ mm}$, $\Delta L_C = 9 \text{ mm}$, $\Delta L_D = 24 \text{ mm}$
- Wire B
- $\frac{2mg}{3aY}$
- Material of rod A is stronger
- 1 mm
- $\frac{\sigma_0 A_0}{\sin^2 \theta}$
- 6:3:4
- 41.6 N, 0.136%
- 2.6 mm
- $2.0 \times 10^{11} \text{ Nm}^{-2}$
- 1, $\frac{13}{20}$
- $\frac{\rho a_0 L^2}{2Y}$
- (a) $F\left(1 - \frac{x}{l}\right)$, (b) $\frac{F}{A}\left(1 - \frac{x}{l}\right)$, (c) $\frac{Fl}{2AY}$, (d) $\frac{F}{2AY}$
- (a) $4.4 \times 10^6 \text{ Nm}^{-2}$ (b) 2.2×10^{-5} (c) $6.6 \times 10^{-5} \text{ m}$
- $Y\left(\frac{R-r}{r}\right)$, $Ybd\left(\frac{R-r}{r}\right)$

Test Your Concepts-II
(Based on Elastic Energy, Energy Density and Poisson's Ratio)

- 39.74 J
- $\frac{F^2 l}{6AY}$
- 0.015 J
- $3 \times 10^8 \text{ Nm}^{-2}$, $\frac{5}{3} \times 10^{-3}$, 3.34 mm, 60 mJ
- $5 \times 10^{-4} \text{ J}$
- $2.25 \times 10^9 \text{ Nm}^{-2}$
- $1 \times 10^8 \text{ Nm}^{-2}$
- $2.5 \times 10^4 \text{ Jm}^{-3}$, 0.20 J

Test Your Concepts-III
(Based on Shear Modulus, Tangential Stress, Shear Strain)

- 333 Pa, 0.133, 2.5 kPa
- 500 Nm^{-2}
- $\frac{\sigma^2 h^3}{2\eta}$
- $5 \times 10^6 \text{ Nm}^{-2}$, $6.25 \times 10^{-6} \text{ m}$

Test Your Concepts-IV
(Based on Bulk's Modulus, Normal Stress and Volumetric Strain)

- $\frac{mg}{3AB}$
- $4.8 \times 10^9 \text{ Nm}^{-2}$, $2.1 \times 10^{-10} \text{ m}^2 \text{ N}^{-1}$
- $1.76 \times 10^9 \text{ Nm}^{-2}$
- $2.525 \times 10^{-4} \%$
- 4.33 kgm^{-3}
- 11.69 gcm^{-3}
- (a) $4.4 \times 10^{-5} \text{ atm}^{-1}$, (b) 22.7 atm
- 23.5 kJm^{-3}
- $1.55 \times 10^5 \text{ Nm}^{-2}$

Test Your Concepts-V
(Based on Fluid Properties, Pressure and Pascal's Law)

- 800 kgm^{-3}
- 1039 kgm^{-3}
- 20 N
- No answer to be given (exclude 4 from answers)
- 570 N
- 52 atm
- 300 cm^3
- R
- 2.5 km
- 1.3 kN
- 138 kPa
- 1 cm, 25.2 cm
- $2 \times 10^4 \text{ Nm}^{-1}$, Clockwise
- 37.5 N
- 0.83 gcm^{-3}
- $\sin^{-1}\left[\frac{\rho_2 h}{(\rho_3 - \rho_1) \ell}\right]$
- $P_0 + \frac{mg}{A}$
- $4\rho g \ell R^2$

Test Your Concepts-VI
(Based on Pressure in Accelerating Fluids)

- $\frac{hg}{l}$
- $10 \text{ cm}, \frac{5}{\pi} \text{ s}^{-1}$
- $\frac{\omega^2 L^2}{2g}$
- 4 ms^{-2}
- $(hg + la)\rho$
- $\frac{\omega^2 x^2}{2g}$

Test Your Concepts-VII
(Based on Archimedes' Principle and Buoyancy)

- 0.1
- $\left(\frac{W}{W - W'}\right)\rho_w$
- 33.3 g
- 24 N, 12 ms^{-2}
- $5 \text{ ms}^{-2}, 2 \text{ s}$
- $T_0\left(1 + \frac{a}{g}\right)$
- $1.00625 \times 10^5 \text{ Pa}$
- $34.3^\circ, 1.6 \text{ N}$ (downwards)
- 13 cm^3
- ZERO
- $3.92 \text{ N}, 6 \text{ N}$

Test Your Concepts-VIII
(Based on Viscosity and Terminal Speed)

- 10^{-3} Nm^{-2}
- 9 ms^{-1}
- $\frac{4\pi R^2 g d}{3(6\pi\eta + K)}$
- $4 \times 10^{-3} \text{ N}$
- $2 \times 10^{-6} \text{ m}$
- $\frac{2}{81} r^4 \left(\frac{\rho - 1}{\eta}\right)^2 g$
- 0.033 cm
- 1590, laminar
- $\frac{64}{81}$
- 6:1

Test Your Concepts-IX
(Based on Equation of Continuity, Bernoulli's Theorem and Applications)

- $\frac{v^2}{2g}$

- 8.6 cm
- 80 ms^{-1}
- $h_2 = 5H, R_{\max} = 10H$ and $h_2 = 6H, R_{\max} = 8\sqrt{3}H$
- 0.5 N
- $10 \text{ ms}^{-2}, 15.5 \text{ ms}^{-1}$
- 4.51 ms^{-1}
- $y = 0.4x^4$
- $6.43 \times 10^{-4} \text{ m}^3 \text{ s}^{-1}$
- 3 minute, 1.5 minute
- $10 \text{ ms}^{-1}, 4 \times 10^4 \text{ Nm}^{-2}$
- $P_0 + \rho g h \left(1 - \frac{R_1^2}{r^2}\right)$
- $\sqrt{2} - 1$
- $\frac{A(h - h_0)}{a\sqrt{2gh_0}}$
- 12.3 ms^{-1}
- $4 \text{ ms}^{-1}, 7.2 \text{ N}, F_{\min} = 0 \text{ N}, F_{\max} = 52.2 \text{ N}$
- $\frac{A}{a} \sqrt{\frac{2H}{g}}$
- 4.9 N
- $1.6 \times 10^{-4} \text{ m}^3 \text{ s}^{-1}, 20 \text{ ms}^{-1}$
- $\sqrt{6}H$
- $v = \sqrt{2gh_1}$ (along the horizontal), $t = \sqrt{\frac{2h_2}{g}}$ and $R = 2\sqrt{h_1 h_2}$
- 2.87 ms^{-1}
- $\frac{A}{a} \sqrt{\frac{2H}{g}} - t_0$

Test Your Concepts-X
(Based on Surface Tension, Surface Energy, Excess Pressure and Capillarity)

- 440 dyne cm^{-2}
- $\frac{kx - mg}{2\pi(R + r)}$
- 2.86 cm
- 1.4 mm
- $\frac{Rr}{R - r}$
- $\frac{2Tl}{g}$
- 6 cm
- $9 \times 10^{-7} \text{ J}$
- 4.76 mm
- 19 mJ
- $144 \times 10^{-7} \text{ J}$
- 10 cm
- $3.75 \times 10^{-6} \text{ m}$
- $1.35 \times 10^{-3} \text{ J}$

Single Correct Choice Type Questions

1. C	2. D	3. A	4. B	5. B	6. A	7. B	8. D	9. B	10. D
11. D	12. A	13. C	14. D	15. C	16. B	17. B	18. A	19. D	20. D
21. A	22. A	23. A	24. A	25. B	26. D	27. C	28. D	29. C	30. B
31. B	32. A	33. C	34. A	35. C	36. D	37. B	38. C	39. C	40. C
41. D	42. A	43. A	44. A	45. C	46. C	47. D	48. A	49. A	50. C
51. A	52. A	53. B	54. C	55. B	56. D	57. C	58. D	59. C	60. A
61. B	62. A	63. C	64. D	65. C	66. A	67. D	68. B	69. D	70. A
71. B	72. B	73. B	74. A	75. C	76. B	77. D	78. D	79. B	80. A
81. C	82. D	83. B	84. A	85. B	86. B	87. B	88. A	89. D	90. D
91. A	92. C	93. C	94. A	95. D	96. C	97. D	98. B	99. D	100. D
101. B	102. B	103. B	104. C	105. B	106. B	107. A	108. C	109. D	110. D
111. C	112. A	113. D	114. B	115. A	116. B	117. C	118. A	119. A	120. C
121. C	122. B	123. B	124. A	125. D	126. B	127. D	128. C	129. A	130. C
131. D	132. B	133. B	134. A	135. A	136. B	137. C	138. B	139. D	140. A
141. D	142. B	143. D	144. B	145. D	146. C	147. A	148. D	149. B	150. D
151. B	152. C	153. B	154. B	155. C	156. B	157. B	158. C	159. D	160. C
161. D	162. D	163. C	164. A	165. A	166. C	167. C	168. D	169. D	170. C
171. D	172. B	173. C	174. D	175. A	176. D	177. C	178. C	179. A	180. C
181. D	182. A	183. A	184. A	185. C	186. D	187. C	188. B	189. D	190. D
191. C	192. C	193. C	194. D	195. D	196. A	197. D	198. D	199. C	200. A
201. C	202. C	203. A	204. B	205. A	206. A	207. B	208. B	209. A	210. C
211. A	212. C	213. A	214. C	215. B	216. D	217. C	218. B	219. D	220. D
221. D	222. B	223. B	224. A	225. A	226. B	227. C	228. D	229. A	230. C
231. B	232. C	233. C	234. A	235. C	236. B	237. C			

Multiple Correct Choice Type Questions

1. A, C	2. B, C	3. B, D	4. A, C	5. B, C, D
6. A, C, D	7. B, C	8. B, D	9. A, D	10. A, B, D
11. B, C, D	12. B, C	13. B, D	14. B, C, D	15. B, C, D
16. A, B, C	17. B, C	18. B, C	19. B, D	20. C, D
21. A, B, C	22. A, B, C, D	23. C	24. B, C, D	25. B, C
26. A, C	27. B, C	28. A, C, D	29. B, D	30. A, B, C
31. C, D	32. A, C, D	33. A, C	34. A, C	35. B, D
36. B, C	37. A, C, D	38. B, D	39. B, C	40. B, C
41. B, C	42. B, C	43. A, C	44. A, B, C	45. A, B, D
46. A, B, C				

Reasoning Based Questions

1. A	2. C	3. B	4. A	5. A	6. C	7. D	8. B	9. A	10. B
11. D	12. A	13. D	14. B	15. C	16. A	17. B	18. B	19. A	20. C
21. C	22. D	23. C	24. D	25. A	26. A	27. A	28. D	29. A	

Linked Comprehension Type Questions

1. D	2. B	3. B	4. A	5. B	6. C	7. A	8. A	9. C	10. B
11. C	12. B	13. C	14. C	15. D	16. A	17. C	18. B	19. C	20. C
21. C	22. C	23. D	24. B	25. B	26. C	27. B	28. D	29. B	30. A
31. C	32. B	33. A	34. C	35. A	36. C	37. A	38. B	39. B	40. C
41. B	42. C	43. D							

Matrix Match/Column Match Type Questions

1. $A \rightarrow (p, t)$	$B \rightarrow (q)$	$C \rightarrow (r)$	$D \rightarrow (s)$	
2. $A \rightarrow (t, r)$	$B \rightarrow (p, r)$	$C \rightarrow (q, r)$	$D \rightarrow (s)$	
3. $A \rightarrow (q)$	$B \rightarrow (r)$	$C \rightarrow (s)$	$D \rightarrow (p)$	
4. $A \rightarrow (p, q, r)$	$B \rightarrow (q, s)$	$C \rightarrow (q)$	$D \rightarrow (q, s)$	
5. $A \rightarrow (p, r, s, t)$	$B \rightarrow (p, t)$	$C \rightarrow (p, q, r, s)$	$D \rightarrow (p, r, s, t)$	
6. $A \rightarrow (s)$	$B \rightarrow (p)$	$C \rightarrow (p)$	$D \rightarrow (p)$	
7. $A \rightarrow (r)$	$B \rightarrow (q)$	$C \rightarrow (p)$	$D \rightarrow (s)$	
8. $A \rightarrow (p, q, s)$	$B \rightarrow (p, r, s)$	$C \rightarrow (p, q, s)$	$D \rightarrow (p)$	
9. $A \rightarrow (r)$	$B \rightarrow (t)$	$C \rightarrow (p)$	$D \rightarrow (p)$	$E \rightarrow (q)$
10. $A \rightarrow (q)$	$B \rightarrow (p, q, r, s)$	$C \rightarrow (q)$	$D \rightarrow (p, q, r, s)$	
11. $A \rightarrow (p)$	$B \rightarrow (q, r)$	$C \rightarrow (s)$	$D \rightarrow (s)$	
12. $A \rightarrow (r)$	$B \rightarrow (s)$	$C \rightarrow (q)$	$D \rightarrow (p)$	
13. $A \rightarrow (p)$	$B \rightarrow (q, r, s)$	$C \rightarrow (p, s)$	$D \rightarrow (q, r)$	
14. $A \rightarrow (r)$	$B \rightarrow (p)$	$C \rightarrow (r)$	$D \rightarrow (p)$	
15. $A \rightarrow (r)$	$B \rightarrow (s)$	$C \rightarrow (p)$	$D \rightarrow (q)$	
16. $A \rightarrow (p)$	$B \rightarrow (p, s)$	$C \rightarrow (q, s)$	$D \rightarrow (p, r)$	
17. $A \rightarrow (q)$	$B \rightarrow (p)$	$C \rightarrow (r)$	$D \rightarrow (t)$	
18. $A \rightarrow (q)$	$B \rightarrow (p)$	$C \rightarrow (r)$	$D \rightarrow (q)$	

Integer/Numerical Answer Type Questions

1. 37	2. 260	3. 4.9, 54.3	4. 16	5. 8.5, 13600, 46
6. 14	7. 0	8. 0.15, 0.13	9. 4.1, 82	10. 2.3
11. 1.91	12. 1025	13. 11.3	14. 6	15. 0.125
16. 3.54	17. 14, lower string	18. 1.3	19. 0.91	20. 50
21. 12, 100	22. 1.24, 779, 1.5	23. 2	24. 27	25. 280
26. 4	27. 570	28. 20	29. 250.2	30. 23
31. 31	32. 145	33. 4.51	34. 10	35. 0.38
36. 10.8	37. 34.64	38. 847	39. 2.34	40. 26
41. 40				

ARCHIVE: JEE MAIN

1. A	2. C	3. A	4. C	5. B	6. B	7. B	8. B	9. 101	10. D
11. D	12. A	13. A	14. C	15. B	16. D	17. 4.00	18. B	19. A	20. D
21. D	22. C	23. B	24. C	25. B	26. C	27. A	28. A	29. D	30. *
31. D	32. C	33. C	34. A	35. C	36. A	37. B	38. C	39. A	40. C
41. D	42. A	43. *	44. A	45. C	46. A	47. C	48. C	49. D	50. D
51. D	52. C	53. D							

* No given option is correct.

ARCHIVE: JEE ADVANCED

Single Correct Choice Type Problems

1. B	2. D	3. C	4. A	5. B	6. B	7. A	8. D	9. A	10. D
11. D	12. A	13. B	14. C	15. A	16. C	17. B	18. A	19. A	20. C

Multiple Correct Choice Type Problems

1. A, B, D	2. A, D	3. A, B	4. A, D	5. A, B, D
6. B, C				

Reasoning Based Questions

1. A

Matrix Match/Column Match Type Questions

1. (A) \rightarrow (p) (B) \rightarrow (p) (C) \rightarrow (p) (D) \rightarrow (s)

Linked Comprehension Type Questions

1. C 2. A 3. C 4. A 5. B 6. C 7. A 8. A

Integer/Numerical Answer Type Questions

1. 9 2. 3.74 3. 2 4. 6 5. 3 6. 6 7. 6